

NVF3 Series  
Inverter

---

# User Instruction

---

# Foreword

---

Thank you for choosing NVF3 series inverters.

NVF3 series inverter adopts speed sensorless vector control technology, which has the characteristics of fast load response, large low-frequency torque, strong overload capacity, etc., and realizes precise control of equipment. This series of inverters has stable voltage output, torque limit, speed Tracking, simple PLC, process PID and other application functions can meet the electrical drive requirements of wire drawing, textile, machine tools, papermaking, packaging, food, plastics, fans, water pumps and various automated production equipment. NVF3 series inverters have a standard RS485 communication protocol, which can expand a variety of communication functions and I/O ports to meet complex control and system integration requirements on site.

The NVF3 series inverter fully considers the harmonic interference, dust and oil pollution of the industrial site power grid. The product has a built-in anti-harmonic interference circuit, which can well suppress harmonic interference. It can meet the complex environmental requirements on site.

NVF3 series inverters are easy to operate and rich in functions, which are not only convenient for beginner inverter operators to use, but also meet the complex application requirements of professional inverter debuggers.

This manual introduces the functional characteristics and usage methods of NVF3 series inverters, including product selection, installation and commissioning, parameter functions, etc. Please read this instruction manual carefully before using the inverter to ensure correct use of the inverter. After reading and using this instruction manual, please keep it properly for future use.



If you encounter difficulties or problems that cannot be solved during use, please contact the company's local distributors or directly contact the company's professional and technical personnel for help. (400 customer service hotline: 400-8177-777)

The company reserves the right to continuously optimize and improve the NVF3 series inverters, and the information is subject to change without prior notice.



# Safety Precautions

- 1 Please read the instruction manual carefully and follow all safety precautions in the manual before handling, installation, operation and maintenance. If ignored, it may cause personal injury or equipment damage, even death.
- 2 If your company or your company's customers fail to comply with the safety precautions in the instruction manual and cause injury and equipment damage, the company will not be liable.



## ◆ Security Definition

Logo	Illustrate
 Danger	Occasions where death or serious injury may result from failure to operate as required.
 Notice	Occasions where moderate or minor injuries, or property damage, may occur due to failure to operate as required.

## ◆ Before installation

 Danger	<ul style="list-style-type: none"><li>◆ If the inverter is damaged or its components are incomplete, please do not install and run it, otherwise there is a risk of fire and injury!</li><li>◆ Do not directly touch the main circuit terminals, control circuit terminals, electronic components and inverter components with your hands!</li></ul>
 Notice	<ul style="list-style-type: none"><li>◆ Whether the product nameplate information is consistent with your order requirements, if not, please do not install!</li><li>◆ If the actual product does not match the packing list, please do not install it!</li></ul>

## ◆ Install

 Danger	<ul style="list-style-type: none"><li>◆ Installation must be performed by qualified personnel, otherwise there is a risk of electric shock!</li><li>◆ Please install it on non-combustible objects such as metal, otherwise there is a risk of fire!</li><li>◆ Do not place combustibles nearby, otherwise there is a risk of fire!</li><li>◆ Do not install in an environment containing explosive gas, otherwise there is a danger of explosion!</li><li>◆ Do not install in direct sunlight, otherwise there is a risk of damage to the equipment!</li><li>◆ It is strictly forbidden to install in places where water droplets may splash, such as water pipes, otherwise there is a risk of damage to the equipment!</li></ul>
 Notice	<ul style="list-style-type: none"><li>◆ When transporting, do not let the operation panel and cover plate be stressed, otherwise there is a danger of damage to the equipment and injury when falling!</li><li>◆ Please install it in a place that can bear the weight of the frequency converter, otherwise there is a danger of damage to the equipment and injury when it falls!</li><li>◆ During installation, it is strictly forbidden to leave thread ends or metal objects in the machine, otherwise there is a danger of fire!</li></ul>

## ◆ Wiring

<p>⚠ Danger</p>	<ul style="list-style-type: none"> <li>⚡ Wiring must be performed by qualified personnel, otherwise there is a risk of electric shock!</li> <li>⚡ Make sure that the input power is completely disconnected before wiring, otherwise there is a risk of electric shock!</li> <li>⚡ The grounding terminal of the inverter must be reliably grounded, otherwise there is a risk of electric shock!</li> <li>⚡ The exposed parts of the main circuit wiring cables must be wrapped with insulating tape, otherwise there is a risk of electric shock!</li> <li>⚡ Do not short-circuit ⊕ with B , otherwise there is a risk of fire and equipment damage! The main circuit terminal and the lead terminal must be firmly connected, otherwise there is a danger of damage to the equipment!</li> <li>⚡ Connect terminals other than R1A , R1B , R1C , R2B and R2A to the AC 220V signal among the control terminals , otherwise there is a danger of damage to the equipment!</li> </ul>
<p>⚠ Notice</p>	<ul style="list-style-type: none"> <li>⚡ Before leaving the factory, all inverters have been tested for withstand voltage, and it is forbidden to conduct withstand voltage tests for inverters, otherwise there is a risk of damage to the equipment!</li> <li>⚡ The motor cable is longer than 100 meters, it is recommended to use multi-stranded wires and install an AC output reactor that can suppress high-frequency oscillation. Avoid motor insulation damage, excessive leakage current and frequent inverter protection!</li> </ul>

## ◆ Run

<p>⚠ Danger</p>	<ul style="list-style-type: none"> <li>⚡ The cover must be closed before power on, otherwise there is a danger of electric shock and explosion!</li> <li>⚡ For inverters that have been stored for more than 2 years, use a voltage regulator to gradually increase the voltage when powering on, otherwise there is a risk of electric shock and explosion!</li> <li>⚡ When the power is on, do not touch the terminals with your hands, otherwise there is a risk of electric shock!</li> <li>⚡ Do not operate the inverter with wet hands, otherwise there is a risk of electric shock!</li> <li>⚡ After replacing the control board, the parameters must be set correctly before it can run, otherwise there is a risk of damage to the equipment!</li> <li>⚡ Non-professional technicians are forbidden to test the signal during operation, otherwise there is a danger of injury or equipment damage!</li> </ul>
<p>⚠ Notice</p>	<ul style="list-style-type: none"> <li>⚡ Please confirm whether the number of phases and rated voltage of the power supply are consistent with the nameplate of the product, otherwise there is a risk of damage to the equipment!</li> <li>⚡ Check the wiring of the main circuit of the inverter to ensure that there is no short circuit and the wiring is tight, otherwise there is a risk of damage to the equipment!</li> <li>⚡ Do not frequently control the start and stop of the inverter by turning on and off the power, otherwise there is a danger of damage to the equipment!</li> <li>⚡ In a domestic environment this product may cause radio interference, in which case additional suppression measures (chokes, filters, etc.) may be required!</li> </ul>

## ◆ Maintenance

<p>⚠ Danger</p>	<ul style="list-style-type: none"> <li>⚡ Product maintenance, maintenance, inspection, or replacement of parts must be performed by qualified personnel, otherwise there is a risk of electric shock!</li> <li>⚡ It is strictly forbidden to leave thread ends or metal objects in the machine, otherwise there is a danger of fire!</li> <li>⚡ It is forbidden to carry out maintenance, maintenance, inspection, or replacement of parts on the product with power on, otherwise there is a risk of electric shock!</li> <li>⚡ 10 minutes after disconnecting the power supply and the voltage of the positive and negative busbars is lower than 36V , otherwise there is a danger of electric shock!</li> </ul>
-----------------	---

⚠ Notice	<ul style="list-style-type: none"> <li>◇ When performing maintenance, maintenance, inspection, or replacement of parts on the product, try not to touch the components, otherwise there is a risk of electrostatic damage to the components!</li> <li>◇ All pluggable devices must be plugged in when the power is off!</li> </ul>
----------	--

#### ♦ Motors and Mechanical Loads

Precautions	Illustrate
Compared with power frequency operation	The output voltage is a PWM wave, which contains certain harmonics. Therefore, the temperature rise, noise and vibration of the motor during use are slightly increased compared with power frequency operation.
Run at low speed	When the frequency converter drives an ordinary motor to run at low speed for a long time, the output torque must be reduced due to the deterioration of the heat dissipation effect of the motor. If it needs to run at low speed and constant torque for a long time, a variable frequency motor must be selected.
Motor electronic thermal protection value	When selecting a suitable motor, the frequency converter can implement thermal protection for the motor. If the motor does not match the rated capacity of the inverter, it is necessary to adjust the protection value or take other protection measures to ensure the safe operation of the motor.
At frequencies above 50Hz	If the operation exceeds 50Hz, in addition to the increased vibration and noise of the motor, it is also necessary to ensure the operating speed range of the motor bearings and mechanical devices. Be sure to check in advance.
Lubrication of mechanical devices	Mechanical devices that require lubrication, such as gearboxes and gears, may be damaged due to poor lubrication effect during long-term low-speed operation, so be sure to check in advance.
Negative torque load	For occasions such as lifting loads, negative torque often occurs, and the inverter often trips due to overcurrent or overvoltage faults. At this time, it should be considered to select a braking component with appropriate parameters.
Mechanical resonance point of load device	The inverter may encounter the mechanical resonance point of the load device within a certain output frequency range, which must be avoided by setting the jump frequency.
Occasions with frequent start and stop	It is suitable for start-stop control of the inverter through terminals. It is strictly forbidden to use contactors and other switching devices on the input side of the inverter for direct frequent start and stop operations, otherwise the equipment will be damaged.
Motor insulation inspection before connecting to the inverter	<p>Before the motor is used for the first time or after being placed for a long time, the insulation of the motor should be checked to prevent the inverter from being damaged due to the insulation failure of the motor winding. Wiring as shown in the figure, please use a 500V voltage type megohmmeter when testing, and ensure that the measured insulation resistance is not less than 5MΩ .</p> <div style="text-align: center;"> <p style="text-align: center;"><b>Motor cable terminals</b></p> <p style="text-align: center;">U V W</p> <p style="text-align: center;">Motor</p> <p style="text-align: center;">Megger</p> <p style="text-align: center;">Grounding</p> </div>

#### ◆ Precautions for use

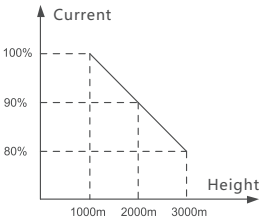
Precautions	Illustrate
Capacitors or varistors to improve power factor	Since the output of the inverter is PWM wave, if a capacitor for improving the power factor or a varistor for lightning protection is installed on the output side, it will cause the inverter to trip due to fault or damage the device, so please remove it.
The use of switching devices such as contactors installed on the output terminals of the inverter	If you need to install switching devices such as contactors between the inverter output and the motor, please ensure that the inverter is on and off when there is no output, otherwise the inverter may be damaged.
Use other than the rated voltage value	It is not suitable to use the frequency converter outside the allowable operating voltage range, if necessary, please use the corresponding step-up or step-down device for voltage transformation.
Lightning Surge Protection	The inverter is equipped with a lightning protection device, which has a certain self-protection ability against induced lightning.
Altitude and Derating	In areas where the altitude exceeds 1000 meters, the heat dissipation effect of the inverter is deteriorated due to the thin air, so it is necessary to use it with derating. As shown in the figure is the relationship curve between the rated current of the inverter and the altitude above sea level. 

#### ◆ Precautions for scrapping

 Notice	<p>The electrolytic capacitor of the main circuit and the electrolytic capacitor on the printed board may explode when burned!</p> <p>Toxic gas will be produced when plastic parts such as panels are burned!</p> <p>Please dispose of as industrial waste!</p>
---	--

# Catalog

---

<b>Foreword</b> .....	<b>I</b>
<b>Safety Precautions</b> .....	<b>II</b>
<b>1 Main purpose and scope of application</b> .....	<b>001</b>
1.1 open box to check .....	<b>001</b>
1.2 The main purpose .....	<b>001</b>
1.3 Scope of application .....	<b>001</b>
<b>2 Series product model and its meaning</b> .....	<b>001</b>
2.1 Series product model machine and its meaning .....	<b>001</b>
2.2 Product Model Specifications .....	<b>002</b>
<b>3 Normal use conditions</b> .....	<b>003</b>
3.1 Normal use environment .....	<b>003</b>
3.2 Transport and storage conditions .....	<b>003</b>
3.3 Installation direction and installation space .....	<b>004</b>
<b>4 Main technical parameters and performance</b> .....	<b>007</b>
4.1 Product Specifications .....	<b>007</b>
<b>5 Structural features and working principle</b> .....	<b>009</b>
5.1 Product main circuit characteristic diagram .....	<b>009</b>
5.2 Product structure feature map .....	<b>010</b>
<b>6 Appearance, installation size and weight</b> .....	<b>011</b>
6.1 Appearance, installation size and weight .....	<b>011</b>
6.2 Outline and installation dimensions of display box and pallet .....	<b>014</b>
<b>7 Installation, commissioning and operation</b> .....	<b>015</b>
7.1 Inspection before installation .....	<b>015</b>
7.2 Main loop terminal explanation .....	<b>015</b>
7.3 Control loop wiring method .....	<b>019</b>
7.4 Wiring method .....	<b>021</b>
7.5 First boot steps .....	<b>023</b>
7.6 Confirmation items when starting the inverter for the first time .....	<b>025</b>
7.7 How to use the operation panel .....	<b>026</b>

# Catalog

---

7.8 Motor self-learning.....	029
7.9 Test run.....	031
7.10 Control Performance Adjustment During Trial Run.....	032
7.11 Checklist for test run.....	034
<b>8 Repair, Maintenance and Storage Precautions .....</b>	<b>035</b>
8.1 Daily maintenance .....	035
8.2 Regular inspection and maintenance .....	035
8.3 Replace wearing parts.....	036
8.4 Storage period and precautions.....	036
<b>9 Fault Analysis and Elimination .....</b>	<b>037</b>
<b>10 Warranty period and environmental protection and other legal regulations .....</b>	<b>043</b>
10.1 Warranty.....	043
10.2 Environmental protection.....	043
<b>11 Product Selection and Ordering Instructions.....</b>	<b>044</b>
11.1 Heavy Duty Rating vs Light Duty Rating.....	044
11.2 Derating of frequency converter.....	044
11.3 Main circuit peripheral device selection.....	044
<b>12 Detailed parameters .....</b>	<b>047</b>
12.1 F0 group basic functions .....	047
12.2 F1 group start and stop control .....	053
12.3 F2 group motor parameters .....	057
12.4 F3 group vector control parameters.....	058
12.5 F4 group V/F control parameters.....	063
12.6 F5 group of input terminals .....	069
12.7 F6 group of output terminals .....	080
12.8 F7 group of keyboard and display .....	085
12.9 F8 group auxiliary function.....	090
12.10 F9 group of PID functions .....	100
12.11 FA group multi-segment instructions, simple PLC function .....	106
12.12 FB group communication parameters.....	112
12.13 Fd group expansion card .....	115



# Catalog

---

12.14 FE group failure and protection .....	115
12.15 FF group User-defined function codes .....	125
12.16 A0 group terminal extension function .....	125
12.17 A5 group second motor parameters .....	129
12.18 U0 group monitoring parameters .....	133
12.19 Modbus communication .....	137
<b>13 General table of parameters .....</b>	<b>144</b>

## 1 Main purpose and scope of application

### 1.1 open box to check

After receiving the product, the following checks are required. If there is any discrepancy, please contact the local dealer:

- ◆Whether the outer packaging of the inverter is complete, whether there is deformation, damage, soaking, damp, etc.;
- ◆Open the package, please check the appearance of the inverter to confirm whether there are scratches, rust, bruises, etc.;
- ◆Please confirm whether the inverter model is consistent with the product you ordered; Please confirm whether the product accessories are complete and consistent;
- ◆If the model is inconsistent or the product is defective, please do not install it, and please contact our company's agent dealer or our company's sales manager immediately.

### 1.2 The main purpose

The frequency converter is mainly used for frequency conversion speed regulation, torque control, improving operation accuracy, improving equipment power factor, overcurrent, overvoltage, overload protection and other functions for AC motors.

At the same time, it also has the effect of saving energy and reducing equipment noise.

### 1.3 scope of application

NVF3 inverter is suitable for two types of loads: (1) constant torque type, (2) variable torque type.

## 2 Series product model and its meaning

### 2.1 Series product model machine and its meaning

The model on the product nameplate uses letters and numbers to indicate the series and product specifications, see Figure 2.1.1.

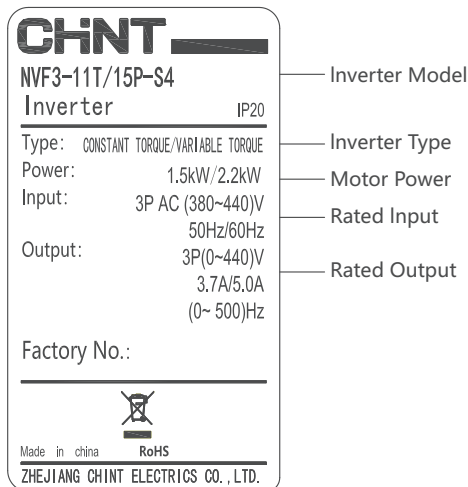

Figure 2.1.1 Description of nameplate

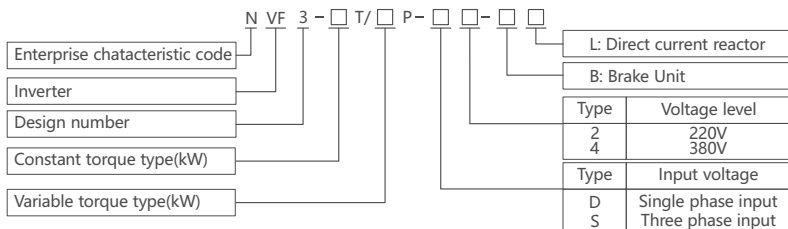

Figure 2.1.2 Product model naming rules

## 2.2 Product Model Specifications

### Table 2.2.1 Specifications and Models of Inverters

Inverters Model	Power capacity (kVA)	Input Current (A)	Heavy load rated current (A)	Light load rated current (A)	Adapting motor (kW) (heavy load / light load)	Braking unit (excluding braking resistor)
NVF3-1.5P-S4	2.8	3.7	-	3.7	1.5P	Standard built-in braking unit
NVF3-1.5T/2.2P-S4	3.0	5.0	3.7	5.0	1.5T/2.2P	
NVF3-2.2T/3.0P-S4	4.2	6.1	5.0	7.2	2.2T/3.0P	
NVF3-3.0T/3.7P-S4	5.0	6.1	7.2	8.5	3.0T/3.7P	
NVF3-3.7T/5.5P-S4	5.9	10.5	8.5	12.2	3.7T/5.5P	
NVF3-5.5T/7.5P-S4	8.6	14.6	12.2	16.2	5.5T/7.5P	
NVF3-7.5T/11P-S4	13	19	16.2	24.6	7.5T/11P	
NVF3-11T/15P-S4	18	26	24.6	31.4	11T/15P	
NVF3-15T/18.5P-S4	25	34	31.4	37	15T/18.5P	
NVF3-18.5T/22P-S4	29	38.5	37	45	18.5T/22P	
NVF3-22T/30P-S4	34	46.5	45	60	22T/30P	Optional built-in braking unit
NVF3-30T/37P-S4	46	62	60	75	30T/37P	
NVF3-37T/45P-S4	57	76	75	90	37T/45P	
NVF3-45T/55P-S4	69	92	90	110	45T/55P	
NVF3-55T/75P-S4	85	113	110	150	55T/75P	
NVF3-75T/90P-S4	114	157	150	176	75T/90P	
NVF3-90T/110P-S4	133	180	176	210	90T/110P	Optional external braking unit
NVF3-110T/132P-S4	160	214	210	253	110T/132P	
NVF3-132T/160P-S4	195	256	253	300	132T/160P	
NVF3-160T/185P-S4	236	307	300	340	160T/185P	
NVF3-185T/200P-S4	267	345	340	380	185T/200P	
NVF3-200T/220P-S4	305	430	380	420	200T/220P	
NVF3-220T/245P-S4	350	477	420	470	220T/245P	
NVF3-245T/280P-S4	403	526	470	520	245T/280P	
NVF3-280T/315P-S4	420	605	520	600	280T/315P	
NVF3-315T/355P-S4	460	647	600	640	315T/355P	
NVF3-355T/400P-S4	500	700	640	690	355T/400P	
NVF3-400T/450P-S4	560	800	690	820	400T/450P	

### **3 Normal use conditions**

#### **3.1 Normal use environment**

- 1) The installation site is indoors or inside the cabinet
- 2) Power supply overvoltage level III
- 3) Ambient temperature and relative humidity

Constant torque inverter:  $-10^{\circ}\text{C}\sim+40^{\circ}\text{C}$ , use with derating between  $+40^{\circ}\text{C}\sim+50^{\circ}\text{C}$ , use with 1% rated power derating for every  $1^{\circ}\text{C}$  increase in temperature. The maximum relative humidity of the air does not exceed 90% ( $+20^{\circ}\text{C}$ ) and 50% ( $+40^{\circ}\text{C}$ ), the rate of change of relative humidity does not exceed 5% per hour, and condensation must not occur.

Dustproof and waterproof grade IP20

- 4) The environmental pollution degree is below 2
- 5) Please install the inverter in the following places:

In places without oil mist, corrosive gas, flammable gas, dust, etc., foreign matter such as metal powder, oil, and water must not enter the inverter. Places without pungent substances and perishable objects. Places without harmful gases and liquids. Places with little salt corrosion and places without direct sunlight. Do not install the inverter on wood and other combustibles.

- 6) Altitude

The altitude of the place of installation and use at rated output shall not exceed 1000m. In areas where the altitude exceeds 1000m, it should be used with derating, and the altitude should be derated by 10% for every 1000m increase in altitude. The highest altitude of the installation and use site should not exceed 3000m.

- 7) Vibration resistance

5~8.5Hz, the displacement is 3.5mm; 8.5~200Hz, the acceleration is not more than  $5.9\text{m/s}^2$

#### **3.2 Transport and storage conditions**

- 1) Please transport and store according to the transport and storage conditions of the product, and the storage temperature and humidity meet the requirements;
- 2) Avoid transportation and storage in water, rain, direct sunlight, strong electric field, strong magnetic field, strong vibration, etc.;
- 3) Avoid product storage for more than 3 months. When the storage time is too long, please carry out strict protection and necessary inspection;
- 4) Please complete the packaging of the product before transporting it by vehicle. For long-distance transportation, a closed box must be used;
- 5) It is strictly forbidden to mix and transport this product with items that may affect or damage the product;
- 6) Please use professional loading and unloading equipment to handle large-size or heavy-weight products;
- 7) When carrying by hand, please be sure to grasp the product shell firmly to avoid falling product parts, otherwise there is a risk of injury;
- 8) When handling the product, be sure to lift it with care, and pay attention to your feet at all times to prevent tripping or falling;
- 9) When the equipment is hoisted by lifting tools, it is forbidden for people to stand and stay under the equipment.

### 3.3 Installation direction and installation space

When using the inverter, pay attention to the installation spacing and distance requirements, as shown in Figure 3.3.1

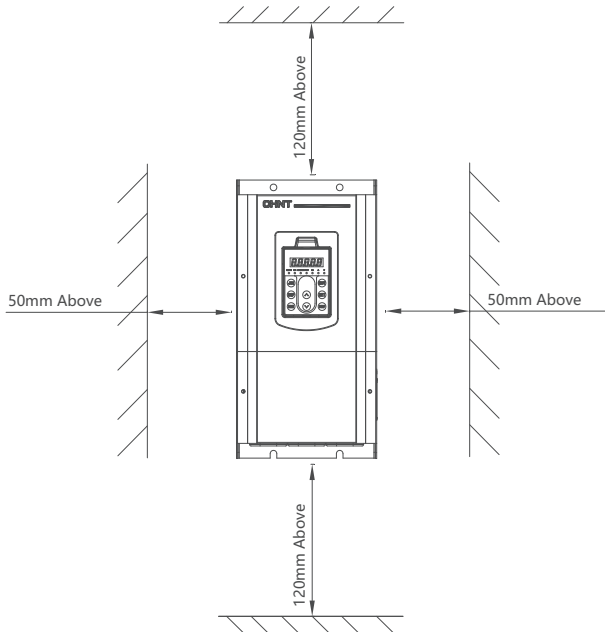

Figure3.3.1 Diagram of inverter installation

For installation of multiple inverters, they can be installed in a vertical or tilted arrangement.

When multiple inverters are installed in a vertical arrangement, a windshield should be added; otherwise, they may affect each other, causing poor heat dissipation. As shown in Figure 3.3.2

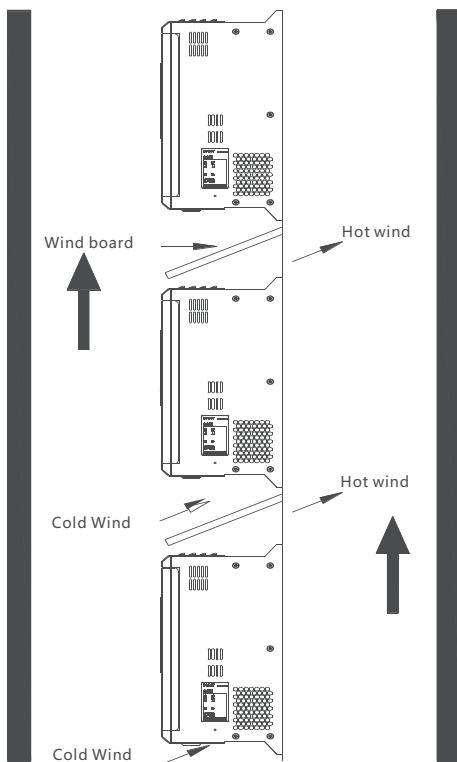
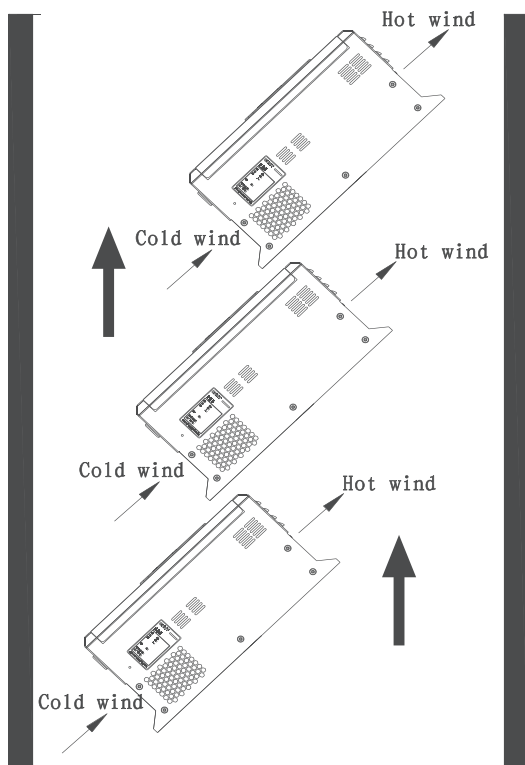

Figure 3.3.2 Installation of multiple inverters in a vertical arrangement

When multiple inverters are installed, it is necessary to ensure that the air ducts on the air inlet side and on the air outlet side are separated to avoid mutual influence, as shown in Figure 3.3.3



**Figure 3.3.3 Installation of multiple inverters in a tilted arrangement**

Note: Since the inverter itself produces a large amount of heat, when it is installed in a cabinet, the cabinet should have good heat dissipation conditions.

## 4 Main technical parameters and performance

### 4.1 Product Specifications

**Table 4.1 Technical specification of NVF3 inverter**

	Project	Project description
Enter	Rated voltage	Three-phase: ( 380-440 )V;
	Frequency	50Hz/60Hz
	Voltage range	Three-phase: 380V(-15%)-440V(+10%)/Single phase:230V(±15%)
	Frequency Range	(47~63)Hz
Output	Voltage	0~rated input voltage
	Frequency	(0-500)Hz
	Overload capacity	T type: 150% rated current for 1 minute, 180% rated current for 2 seconds P type: 120% rated current for 1 minute, 150% rated current for 1 second
Main control performance	Control method	No PG vector control (SVC) ; With PG vector control (FVC); V/F control ;
	Modulation	Space Vector PWM Modulation
	Starting torque	SVC : 150% rated torque at 0.25Hz FVC : 180 % rated torque at 0Hz V/F : 150% rated torque at 0.5Hz
	Frequency resolution	Digital setting: 0.01Hz; Analog setting: maximum frequency x 0.5%
	Torque boost	Automatic torque boost, manual torque boost
	V/F curve	Straight line V/F curve, V/F complete separation mode, V/F semi-separated mode , multi-point V/F curve method
	Acceleration and deceleration curve	Linear acceleration and deceleration (4 types)
	Automatic current limiting	Automatically limit the current during operation to prevent frequent over-current fault tripping
Customization function	Jog	Jog frequency range: ( 0.10 ~50.00) Hz Jog acceleration and deceleration time ( 0.1-6000.0 )s
	Multi-speed operation	Realize multi-stage speed operation through control terminals
Peripheral Interface Features	Run command channel	Operation panel setting, control terminal setting and communication control setting can be switched in various ways
	Digital input	5 multifunctional digital programmable inputs , including 1 HDI high-speed pulse input
	Digital output	1 channel multi-functional digital programmable output ,can be set to high-speed pulse output or open collector output
	Analog input	2 analog signal inputs Optional (0~20) mA, (4~20) mA current signal input or (0 -10) V voltage signal input
	Analog output	2 analog signal outputs Respectively select (0~20) mA, (4~20) mA current output or (0~10) V voltage output, which can realize the output of physical quantities such as set frequency and output frequency
	Relay output	2 relay outputs, of which 1 is normally open and normally closed conversion output, and 1 is normally open output . Contact capacity: NO 5A , NC 3A , 250V(AC)
	RS485 communication interface	1 channel, support Modbus protocol



Operation panel	LED display	Can display more than 20 parameters such as set frequency, output frequency, output voltage, output current, etc.
	Key lock	Realize the locking of all or part of the keys
	Feature selection	Define the scope of action of some keys to prevent misuse
Protective function	With overcurrent protection, overvoltage protection, undervoltage protection, overheat protection, overload protection, phase loss protection and other protection functions	
Structure	Degree of protection	IP20
	Cooling method	Axial DC fan cooling
Installation method	Wall-mounted , flanged	
Efficiency	37kW and below $\geq 93\%$ ; 45 kW and above $\geq 95\%$	

## 5 Structural features and working principle

### 5.1 Product main circuit characteristic diagram

The main circuit of NVF3 series inverter includes rectifier bridge, pre-charging circuit, DC bus support capacitor, braking module, inverter bridge and other devices and circuits. The topology diagram of the main circuit is shown below.

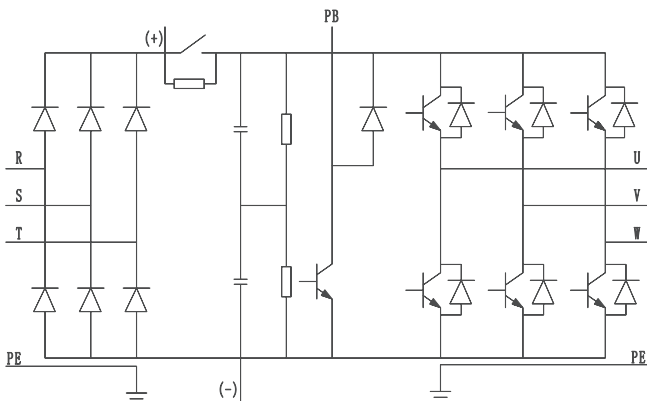

Figure 5.1.1 Simplified diagram of the main circuit below NVF3-15T/18.5P (inclusive) (less than 220V)

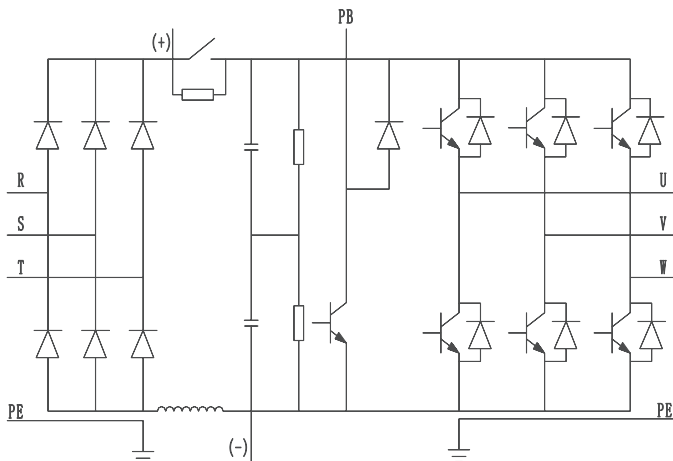

Figure 5.1.2 Simplified diagram of the main circuit of models above NVF3-18.5T/22P (more than 220V)

## 5.2 Product structure feature map

NVF3 has two material structure types, 22T/30P and below models are of plastic case structure, 30T/37P and above models are of sheet metal structure. As shown below:

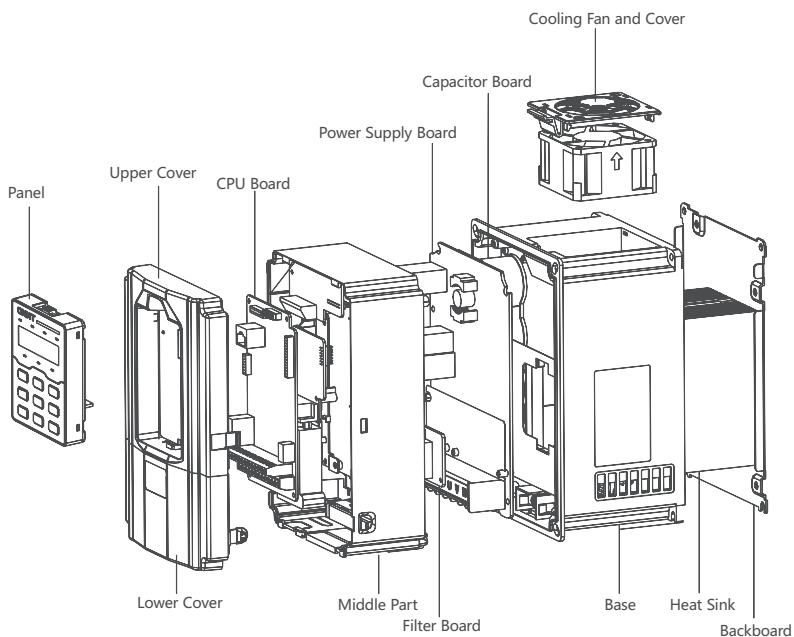

Figure 5. 2 .1 Structural features of NVF3 inverter

## 6 Appearance, installation size and weight

### 6.1 Appearance, installation size and weight

The appearance and installation of the product frame are as follows

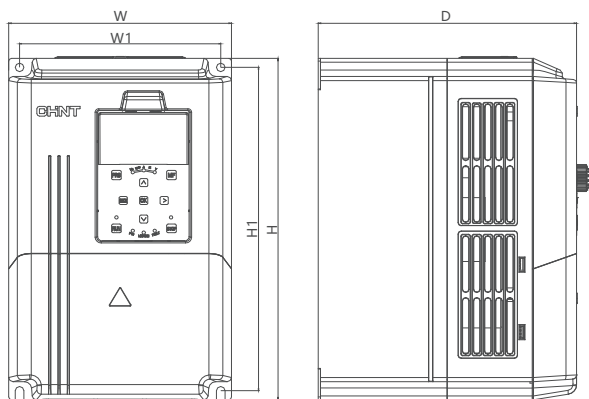

Figure 6.1 Drawings of appearance and installation size of NVF3-15P-S4~NVF3-15P-S4

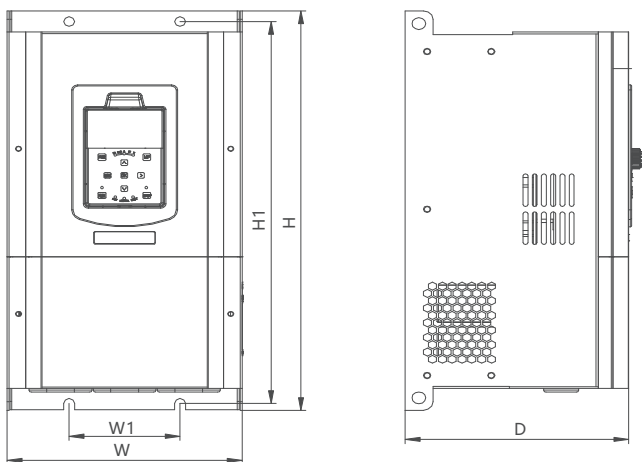

Figure 6.2 Drawings of appearance and installation size of NVF3-15T-S4~NVF3-30P-S4

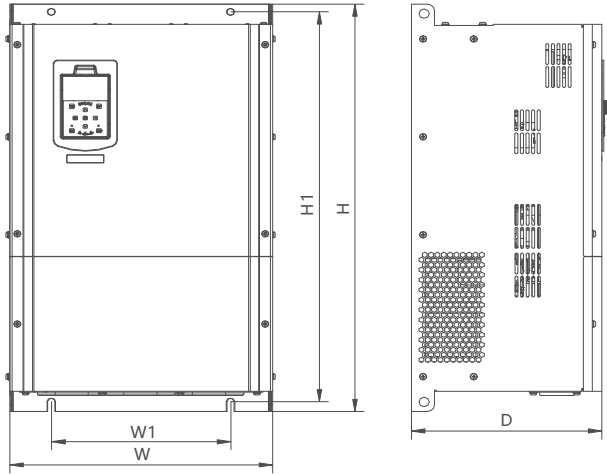

Figure 6.1.3 Drawings of appearance and installation size of NVF3-30T-S4~NVF3-75P-S4

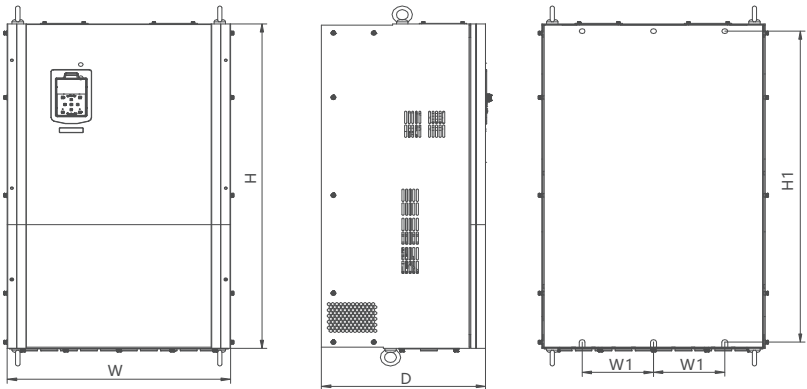
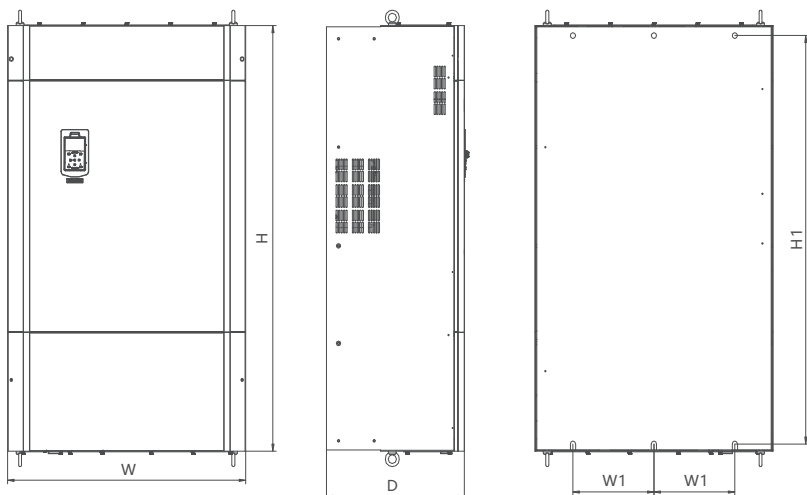

Figure 6.1.4 Drawings of appearance and installation size of NVF3-75T-S4~NVF3-315P-S4

**Figure 6.1.5 Drawings of appearance and installation size of NVF3-315T-S4~NVF3-400T-S4**

◆ The product shape, installation size and weight are summarized as follows:

**Table 6.1 Product appearance, installation dimensions and weight**

Inverter model	W	H	D	W1	H1	D1	Mounting hole d	Weight (Kg)	Remark
NVF3-1.5P-S4	118	187	173	106	175	110	Φ5	2.4	Shown in figure 6.1.1
NVF3-1.5T-S4 (2.2P-S4)									
NVF3-2.2T-S4 (3.0P-S4)									
NVF3-3.0T-S4 (3.7P-S4)									
NVF3-3.7T-S4 (5.5P-S4)									
NVF3-5.5T-S4 (7.5P-S4)	155	247	189	140	232	125	Φ6	3.6	Shown in figure 6.1.1
NVF3-7.5T-S4 (11P-S4)									
NVF3-11T-S4 (15-S4)									
NVF3-15T-S4 (18.5P-S4)	191	378	183	90	362	129	Φ9	10.5	Shown in figure 6.1.2
NVF3-18.5T-S4 (22P-S4)									
NVF3-22T-S4 (30P-S4)	215	426	213	120	407	164	Φ10.5	15	Shown in figure 6.1.2
NVF3-30T-S4 (37P-S4)	259	433	240	140	408	179	Φ10.5	26	Shown in figure 6.1.3
NVF3-37T-S4 (45P-S4)									
NVF3-45T-S4 (55P-S4)	352	603	257	240	577	197.5	Φ10	34	Shown in figure 6.1.3
NVF3-55T-S4 (75P-S4)									
NVF3-75T-S4 (90P-S4)	406	631	272	126	600	224	Φ10	58	Shown in figure 6.1.4
NVF3-90T-S4 (110P-S4)									
NVF3-110T-S4 (132P-S4)	470	807	352	150	769	226.5	Φ12	100	Shown in figure 6.1.4
NVF3-132T-S4 (160P-S4)									
NVF3-160T-S4 (185P-S4)	540	892	390	180	848	256	Φ12	121	Shown in figure 6.1.4
NVF3-185T-S4 (200P-S4)									
NVF3-200T-S4 (220P-S4)									

Inverter model	W	H	D	W1	H1	D1	Mounting hole d	Weight (Kg)	Remark
NVF3-220T-S4 (245P-S4)	710	1020	386	250	978	284	Φ13	171.5	Shown in figure 6.1.4
NVF3-245T-S4 (280P-S4)									
NVF3-280T-S4 (315P-S4)									
NVF3-315T-S4(355P-S4)	734	1200	426	250	1152	313	Φ16.5	280	Shown in figure 6.1.5
NVF3-355T-S4 (400P-S4)									
NVF3-400T-S4(450P-S4)									

## 6.2 Outline and installation dimensions of display box and pallet

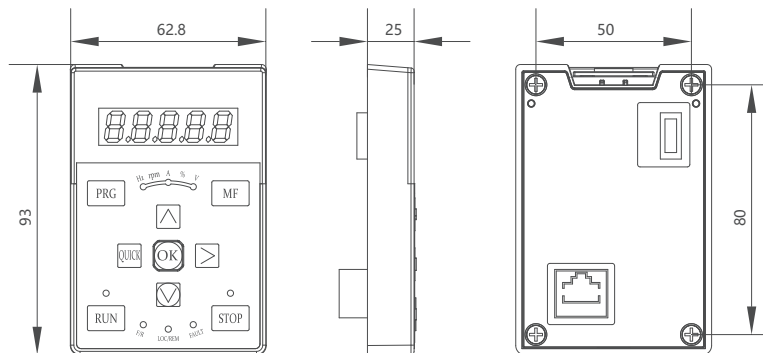
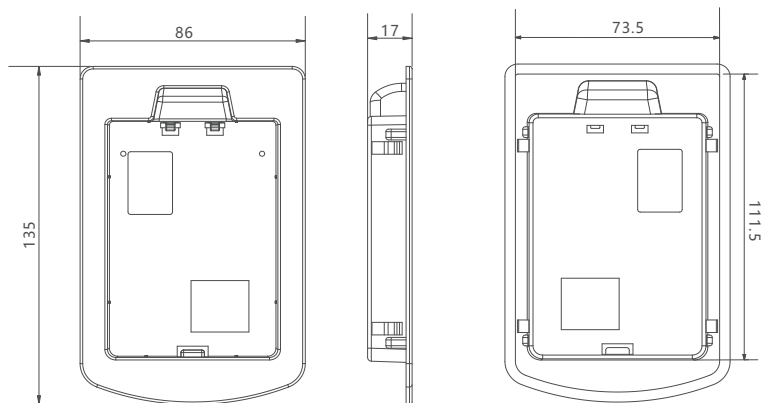

Figure 6.2.1 Display box shape dimensions

With the exception of plastic case models, when all sheet metal cases are installed with display boxes, the following must be buckled up with the display box bracket before the display box can be mounted on the chassis. The shape of the tray:



Note: 73.5\*111.5 is recommended sheet metal opening size

Figure 6.2.2 shape dimensions of bracket plate

## 7 Installation, commissioning and operation

### 7.1 Inspection before installation

♦ Installation Environment

- 1) The installation site is indoors or inside the cabinet
- 2) Power supply overvoltage level III
- 3) Ambient temperature and relative humidity

Constant torque inverter:  $-10^{\circ}\text{C}\sim+40^{\circ}\text{C}$ , use with derating between  $+40^{\circ}\text{C}\sim+50^{\circ}\text{C}$ , use with 1% rated power derating for every  $1^{\circ}\text{C}$  increase in temperature.

The maximum relative humidity of the air does not exceed 90% ( $+20^{\circ}\text{C}$ ) and 50% ( $+40^{\circ}\text{C}$ ), the rate of change of relative humidity does not exceed 5% per hour, and condensation must not occur.

Dustproof and waterproof grade IP20

- 4) The environmental pollution degree is below 2

- 5) Please install the inverter in the following places:

Places free of oil mist, corrosive gases, flammable gases, dust, etc., places free of irritating substances, explosives, harmful gases and liquids, places with little salt erosion, and places without direct sunlight. Do not install the inverter on top of flammable materials such as wood.

- 6) Altitude

The altitude of the place of installation and use at rated output shall not exceed 1000m.

In areas where the altitude exceeds 1000m, it should be used with derating, and the altitude should be derated by 10% for every 1000m increase in altitude. The highest altitude of the installation and use site should not exceed 3000m.

- 7) Vibration resistance

5 ~ 8.5Hz, displacement 3.5mm; 8.5 ~ 200Hz, acceleration not greater than  $5.9\text{m/s}^2$ .

### 7.2 Main loop terminal explanation

- (1) Triphase (380~440) V series (NVF3-1.5P-S4~30P-S4)

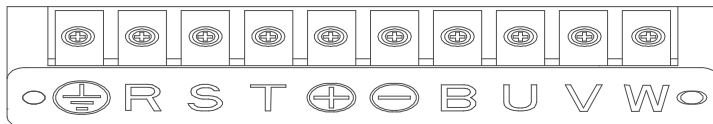

Figure 7.2.1 Main loop terminal NVF3-1.5P-S4~30P-S4

- (2) Triphase(380~440)V series(NVF3-30T-S4~45P-S4)

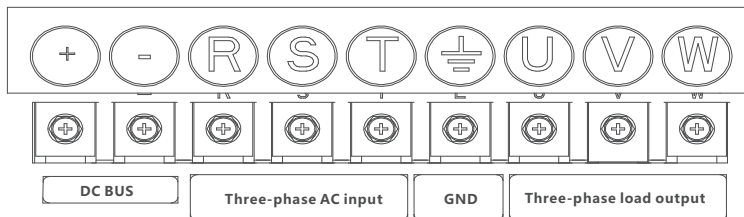

Figure 7.2.2 Main loop terminal NVF3-30T-S4~45P-S4



(3) Triphase (380~440) V series (NVF3-45T-S4~110P-S4)

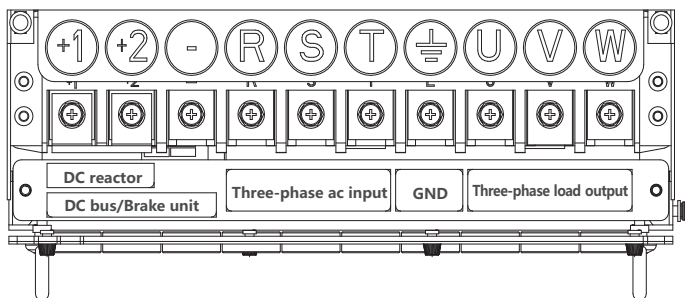

Figure 7.2.3 Main loop terminal NVF3-45T-S4~110P-S4

(4) Triphase(380~440) V series NVF3-110T-S4~160P-S4

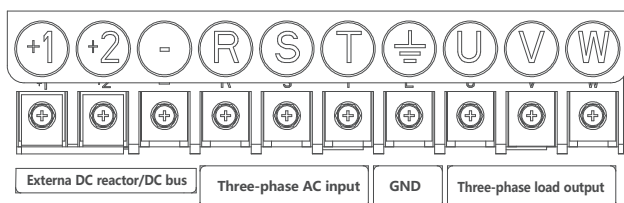

Figure 7.2.4 Main loop terminal NVF3-110T-S4~160P-S4

Description: Connecting DC reactor between ⊕ and ⊖ ; Connecting DC bus between ⊕ and ⊖ ; For the NVF3-110T-S4~160P-S4 model, When braking is needed, Connecting Brake resistor outside between ⊕ and ⊖ .

(5) Triphase(380~440) V series NVF3-160T-S4~315P-S4

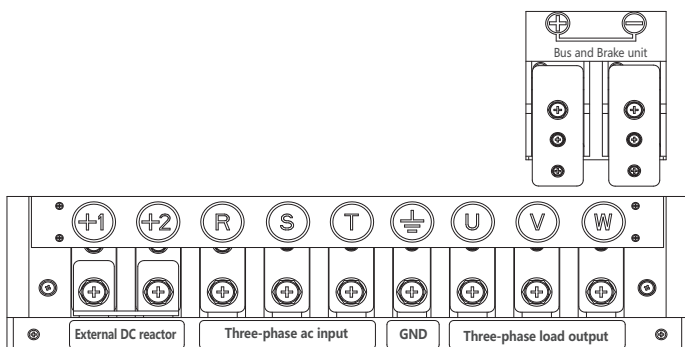

Figure 7.2.5 Main loop terminal NVF3-160T-S4~315P-S4

Description: Connecting DC reactor between ⊕ and ⊖ ; Connecting DC between ⊕ and ⊖ , When braking is needed, Connecting Brake resistor outside between ⊕ and ⊖ .

(6) Triphase (380~440) V series NVF3-315T-S4~400T-S4

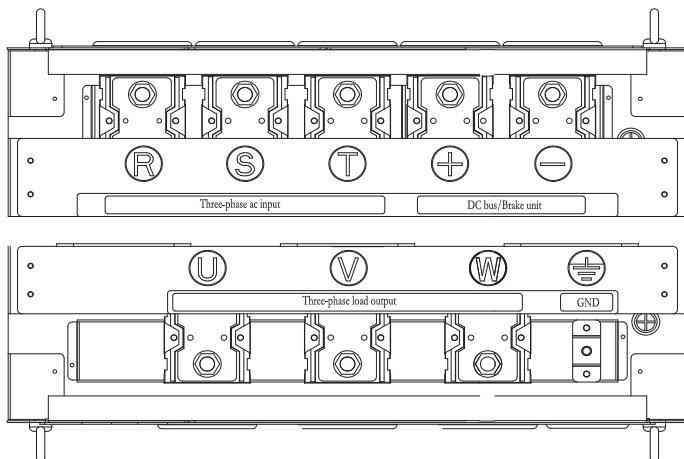

Figure 7.2.6 Main loop terminal NVF3-315T-S4~400T-S4

Description: Connecting DC between ⊕ and ⊖ , When braking is needed, Connecting Brake resistor outside between ⊕ and ⊖.

Table 7.2.1 Main loop terminal description table

Terminal sign	Terminal name	Functional description
R, S, T	Main circuit power input	Triphase AC input Connecting with power grid
U, V, W	Inverter output	Triphase AC output Connecting with motor
⊕	GND or PE	PE, must be reliably grounded at the ground end of Safety Protection
⊕ ⊖	DC busbar or external brake components connecting terminal	As direct current busbar access or external brake components connection terminal, need to be connected according to actual needs
+1 -		
+1 +2	DC reactor connection terminal	For external DC reactors, be sure to remove the short circuit when connecting the DC reactor
⊕ ⊖	External brake resistor connecting terminal	When applied to external brake resistor connecting terminal, connect according to actual requirement

Table 7.2.2 Main loop terminal wiring and mounting torque

Models of Inverter	R、S、T、 $\oplus$ 、 $\ominus$ 、 $\textcircled{1}$ 、 $\textcircled{2}$ 、U、V、W		
	Terminal screw	Tightening torque(N·m)	Wire specification (mm <sup>2</sup> )
NVF3-1.5P(T)S4	M4	1.2~1.5	2.5
NVF3-2.2P(T)S4	M4	1.2~1.5	2.5
NVF3-3.0P(T)S4	M4	1.2~1.5	4
NVF3-3.7P(T)S4	M4	1.2~1.5	4
NVF3-5.5P(T)S4	M4	1.2~1.5	6
NVF3-7.5P(T)S4	M4	1.2~1.5	6
NVF3-11P-S4	M4	1.2~1.5	6
NVF3-11T-S4	M5	2.5~3.0	6
NVF3-15P(T)S4	M5	2.5~3.0	6
NVF3-18.5P(T)S4	M5	2.5~3.0	10
NVF3-22P-S4	M5	2.5~3.0	16
NVF3-22T-S4	M8	9.0~10.0	16
NVF3-30P(T)S4	M8	9.0~10.0	25
NVF3-37P(T)S4	M8	9.0~10.0	25
NVF3-45P(T)S4	M8	9.0~10.0	35
NVF3-55P(T)S4	M8	9.0~10.0	50
NVF3-75P(T)S4	M8	9.0~10.0	60
NVF3-90P(T)S4	M8	9.0~10.0	70
NVF3-110P-S4	M8	9.0~10.0	100
NVF3-110T-S4	M10	17.6~22.5	100
NVF3-132P(T)S4	M10	17.6~22.5	150
NVF3-160P-S4	M10	17.6~22.5	185
NVF3-160T-S4	M12	31.4~39.5	185
NVF3-185P(T)S4	M12	31.4~39.5	185
NVF3-200P(T)S4	M12	31.4~39.5	240
NVF3-220P-S4	M12	31.4~39.5	150×2
NVF3-220T-S4	M16	85.2~90.4	150×2
NVF3-245P(T)S4	M16	85.2~90.4	150×2
NVF3-280P(T)S4	M16	85.2~90.4	185×2
NVF3-315P(T)S4	M16	85.2~90.4	250×2
NVF3-355P(T)S4	M16	85.2~90.4	325×2
NVF3-400P(T)S4	M16	85.2~90.4	325×2

Table 7.2.3 Ground wire standard

Power line conductor cross section S(mm <sup>2</sup> )	Grounding conductor cross section(mm <sup>2</sup> )
S≤16	S
16<S≤35	16
35<S	S/2

### 7.3 Control loop wiring method

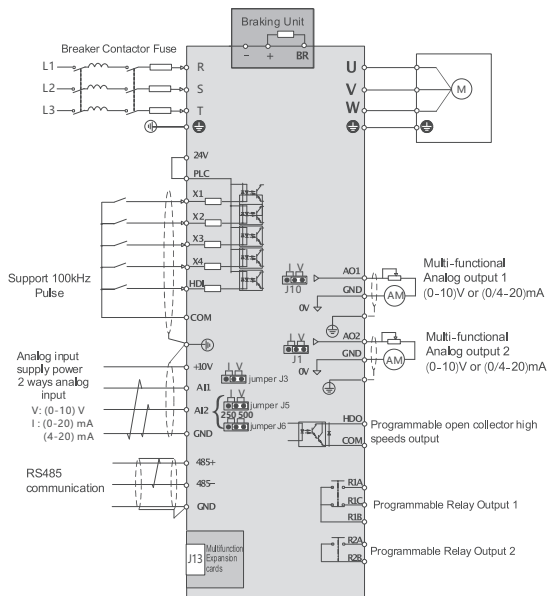

Figure 7.3.1 Schematic diagram of control terminals and wiring

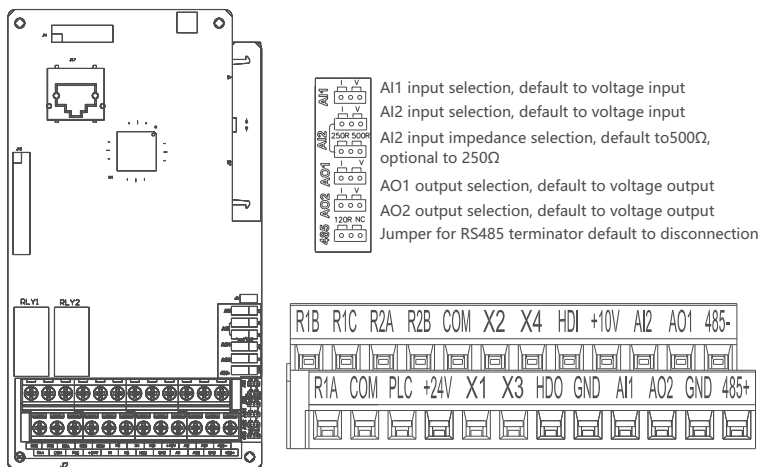

Figure 7.3.2 Arrangement of control circuit terminals

Table 7.3.1 Control terminal function table

Category	Terminal	Name	Terminal function description	
Power supply	+10V	+10V power supply	Provide +10V power supply to the outside, the maximum output current: 10mA Generally used as an external potentiometer	
	GND	+10V power ground	Generally used as an external potentiometer working power supply, potentiometer resistance range: 1k $\Omega$ ~5k $\Omega$	
	+24V	+24V power supply	Provide +24V power supply to the outside, generally used as digital input and output terminal working power supply and external sensor power supply	
	COM	+24V power supply common	Maximum output current: 200mA	
	PLC	External power input terminal	The factory default is connected to + 24V through a short piece When using external power supply to drive X1~X4 and HDI, the PLC needs to be connected to the external power supply and disconnected from the + 24V power supply terminal	
Analog input	AI1	Analog single-ended input AI1	Voltage input range: 0Vdc~10Vdc, Current input range: 0mA~20mA or 4mA~20mA Determined by jumper J3 jumper selection Input impedance: 22k $\Omega$ for voltage input , 500 $\Omega$ for current input	
	AI2	Analog single-ended input AI2	Voltage input range: 0Vdc~10Vdc, Current input range: 0mA~20mA or 4mA~20mA Determined by jumper J5 jumper selection Input impedance: 22k $\Omega$ for voltage input , 500 $\Omega$ or 250 $\Omega$ for current input via jumper J6	
Analog output	AO1	Analog output	output The voltage or current output is determined by the jumper selection of J10 and J1 on the control board	
	AO2	Analog output	Output voltage range: 0V~10V Output current range: 0mA~20mA or 4mA~20mA	
Communication	485+	RS485 communication interface	485 differential signal positive terminal	Standard RS485 communication interface Please use twisted pair or shielded wire
	485-		485 differential signal negative terminal	
Digital input terminal	X1	Multi-function input terminal 1	Optocoupler isolation, compatible with bipolar input Input Impedance: 1.39k $\Omega$ Voltage range for active level input: 18V~30V Programmable multi-function digital input terminals, see function codes F5-00 ~ F5-03	
	X2	Multi-function input terminal 2		
	X3	Multi-function input terminal 3		
	X4	Multi-function input terminal 4		
	HDI	High-speed input terminal HDI	In addition to the characteristics of X1~X4, it can also be used as a high-speed pulse input channel Maximum input frequency: 100kHz Input Impedance: 1.03k $\Omega$	
Digital output terminal	HDO	High-speed pulse output terminal	by parameter F6-00 HDO terminal output mode selection When used as high-speed pulse output, the highest frequency is 100kHz , (set by F6-09 ) When used as an open-collector output, it can be programmed with multiple functions as a pulse signal output terminal, see function code F6-01	

Category	Terminal	Name	Terminal function description
Relay output terminal 1	R1B R1A	Normally open terminal contacts	Programmable multi-function relay output terminal, see function code F6-02 Contact drive capacity: 5A 250V (AC) 30Vdc, 1A
	R1B R1C	Normally closed terminal contacts	
Relay output terminal 2	R2B R2A	Normally open terminal contacts	Programmable multi-function relay output terminal, see function code F6-04 Contact drive capacity: 5A 250V (AC) 30Vdc , 1A

## 7.4 Wiring method

### 7.4.1 Analog input terminal

Because the weak analog voltage signal is particularly susceptible to external interference, it is generally necessary to use shielded cables, and the wiring distance should be as short as possible, not exceeding 20m. In some occasions where the analog signal is severely interfered, a filter capacitor or a ferrite core should be added to the source side of the analog signal.

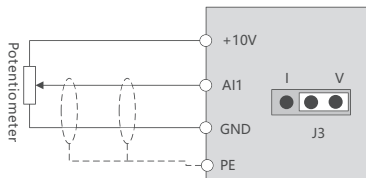

Analog AI1 voltage input

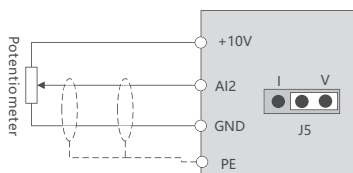

Analog AI2 voltage input

Figure 7.4.1 Wiring diagram of analog voltage input terminal

### 7.4.2 Digital input terminal

- Sink type wiring

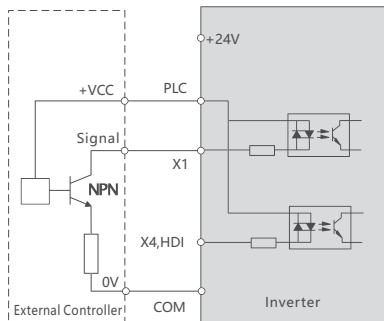
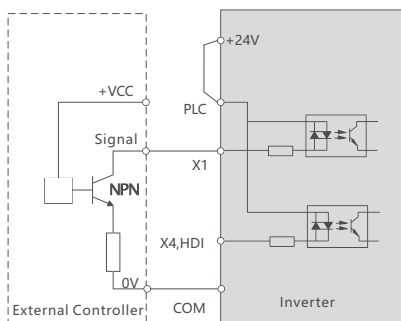
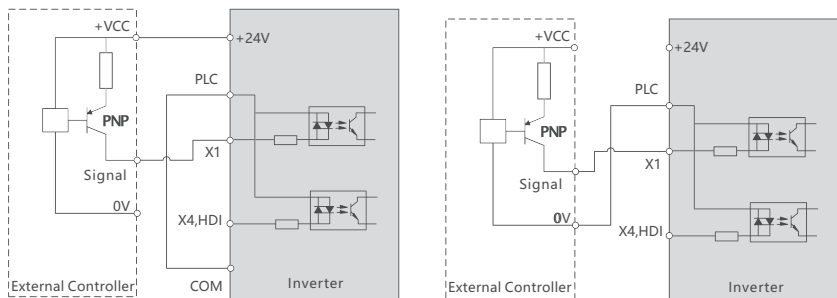

Figure 7.4.2 Sink type connection mode

The most commonly used wiring method is to use the internal 24V power supply of the inverter. Short-circuit the PLC of the inverter to the +24V terminal, and connect the COM terminal of the inverter to the 0V of the external controller.

If you use an external 24V power supply, you must remove the jumper between +24V and PLC, connect the +24V positive pole of the external power supply to the PLC terminal, and connect the 0V external power supply to the corresponding X terminal after passing through the control contact of the controller.

- Source type wiring



Internal 24V Source Mode Connection

External 24V Source Mode Connection

**Figure 7.4.3 Source type wiring mode**

If you use the internal 24V power supply of the inverter, you must remove the short circuit between +24V and PLC, connect PLC with COM, and connect +24V with the common terminal of the external controller.

If an external power supply is used, the jumper between +24V and PLC must be removed, and the PLC and 0V of the external power supply must be connected together. The 24V positive pole of the external power supply is connected to the corresponding X terminal after passing through the control contact of the external controller.

- High-speed input terminal HDI wiring method

When HDI is used as high-speed pulse input, the maximum allowable frequency is 100kHz.

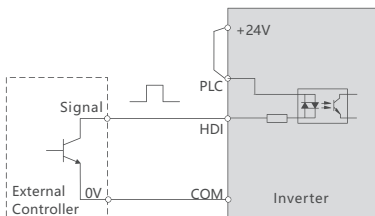
**Figure 7.4.4 High-speed pulse input**

- Digital output terminal

When the digital output terminal needs to drive a relay, an absorption diode should be installed on both sides of the relay coil. Otherwise, it is easy to cause damage to the DC 24V power supply. The driving capacity is not more than 50mA.

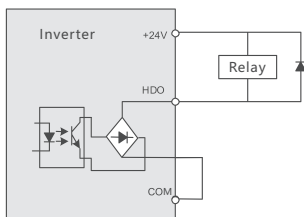
**Figure 7.4.5 Wiring diagram of digital output terminals**

When the HDO terminal is continuous pulse output, the maximum output frequency is 100kHz.

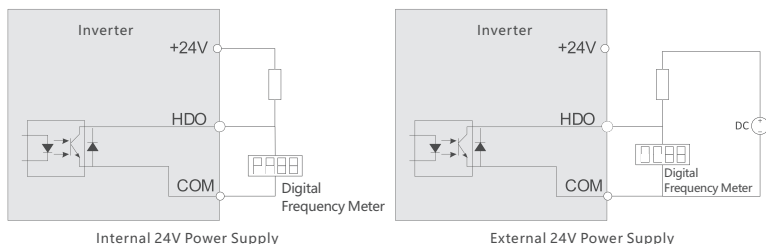

Figure 7.4.6 High-speed digital output terminal wiring diagram

### 7.5 First boot steps

The following describes the basic setting steps necessary for the initial start-up of the inverter.

◆Process 1: Basic debugging process

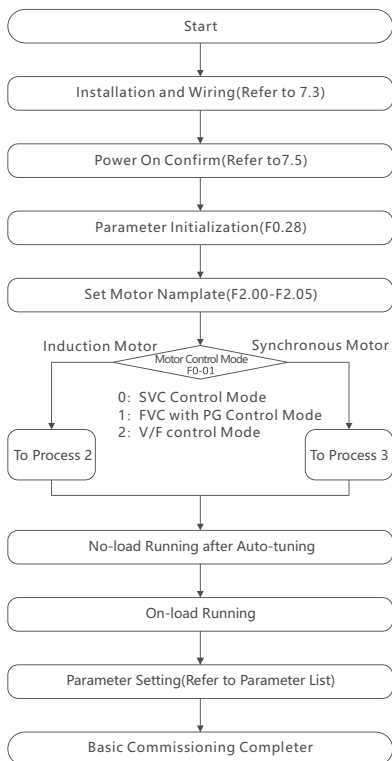

Figure 7.5.1 Basic debugging flow chart



Common parameter table				
Parameter	Name	Predetermined area	Factory default	Change
F0-02	Run command selection	0 : Operation panel 1 : terminal 2 : Communication	0	○
F0-03	Main frequency command input selection	0 : digital setting (no memory when power off) 1 : Digital setting(power-down memory) 2 : AI1 3 : AI2 4 : AI3 5 : Pulse setting ( HDI ) 6 : Multi-segment instruction 7 : Simple PLC 8 : PID 9 : Communication setting	0	◎
F0-08	Preset frequency	0.00Hz~ maximum frequency ( F0-10 )	50.00Hz	○
F0-09	Running direction	0 : run in the default direction 1 : run in the opposite direction from the default direction	0	○
F0-17	Acceleration time 1	0.00s~650.00s(F0-19=2) 0.0s~6500.0s(F0-19=1) 0s~65000s(F0-19=0)	Model confirmed	○
F0-18	Deceleration time 1	0.00s~650.00s(F0-19=2) 0.0s~6500.0s(F0-19=1) 0s~65000s(F0-19=0)	Model confirmed	○
F0-28	Parameter initialization	0 : no operation 01 : Clear record information 02 : Restore factory parameters, excluding motor parameters 04 : backup user's current parameters 05 : restore user backup parameters	0	◎
F1-00	Start method	0 : direct start 1 : Speed tracking and restart 2 : Pre-excitation start (AC asynchronous machine)	0	○
F1-03	Start frequency	0.00Hz~50.00Hz	0.00Hz	○
F1-04	Starting frequency hold time	0.0s~100.0s	0.0s	◎

◆ Process 2: Induction motor self-learning process

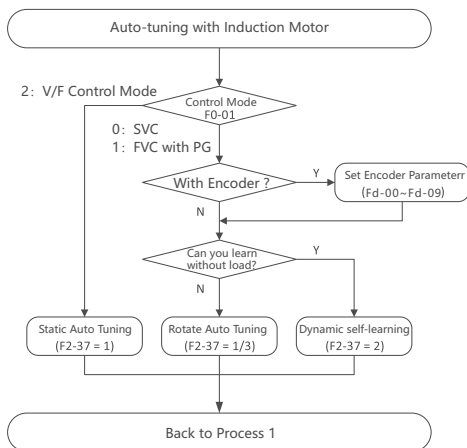

Figure 7.5.2 Self-learning of induction motor

7.6 Confirmation items when starting the inverter for the first time

Before the inverter is powered on, please confirm the items in Table 7.6.1.

Table 7.6.1 Confirmation items when the inverter starts up for the first time

Stage	Project	Content
Before power transmission	Input supply voltage	Please confirm whether the input power specification is consistent with the product specification 220V class: 380V class:
	Main circuit input power wiring	Please confirm that the input power is correctly connected to terminal R/S/T
	Main circuit output and motor wires	Please confirm that the output terminal U/V/W and the motor terminal U/V/W are connected correctly, and the screws are tightened according to the torque requirements
	Brake resistor/brake resistor wiring	Please confirm whether the product model has a brake function Please confirm that the braking resistor is correctly connected to the "+" terminal and "B terminal" Please confirm that the external braking unit is correctly connected to the "+" and "-" terminals
	Grounding	Please confirm that the inverter and motor are properly grounded, the grounding wire meets the requirements and the screws are tightened according to the torque requirements
	Control circuit wiring	Please confirm that the control circuit is connected correctly and the control terminal screws are tightened according to the torque requirements.

Before power transmission	Motor and Mechanical Load Connections	Before the first operation, please ensure that the motor shaft and the mechanical load are kept disconnected, and the mechanical load is not connected until the motor runs normally without load Please confirm the distance between the inverter and the motor and the length of the cable
After power transmission	Operation panel status	Inverter is in standby state, no fault state (with photos)
	DC bus voltage	Press the ">" key to switch to confirm that the bus voltage meets the requirements The DC bus voltage VDC is about 1.4 times of the AC input voltage Vin
Preparation for first commissioning	Debug according to specification	See chapter 7.4

## 7.7 How to use the operation panel

◆The operation panel is shown in the figure below:

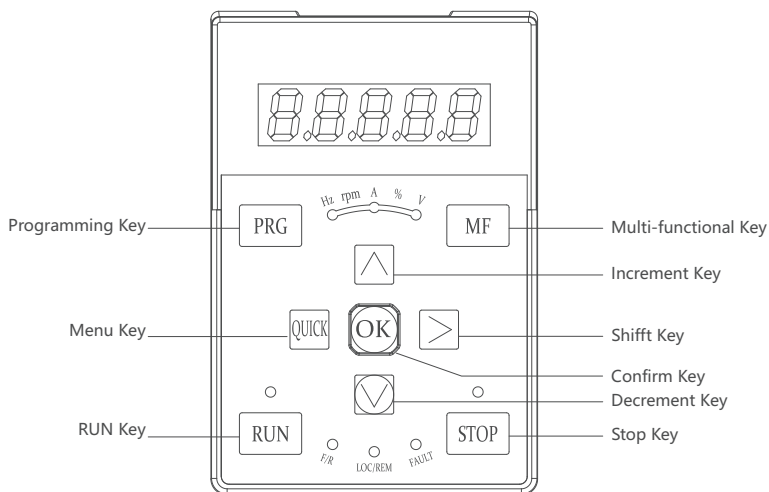

**Figure 7.7.1 Operation panel diagram**

◆ Indicator light description:

The indicator light is divided into status indicator light and unit indicator light. The description of the status indicator light is as follows:

Indicator light	Display state	Show instructions
RUN ( run indication )	Bright	Operating status
	off	downtime
LOC/REM ( control mode indication )	off	panel control
	Bright	terminal control
	flashing	communication control
F/R ( direction indication )	Bright	run in reverse
	off	forward run
ALM (malfunction indication )	Bright	In torque control
	slow flashing	Motor parameter tuning
	flashing fast	Inverter fault

The unit indicator lights are described as follows:

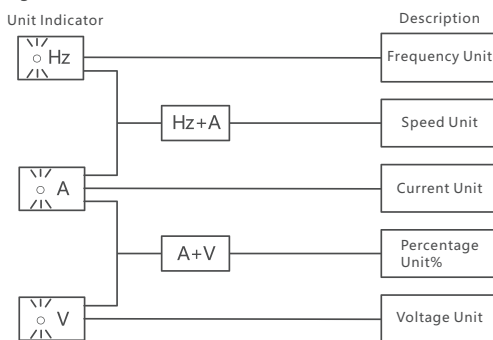

**Figure 7.7.2 Schematic diagram of unit indicator light**

Button function description:

Button	Function	Describe
	programming button	Enter the interface of the first level/return to the interface of the previous level
	Enter	Confirm key (data or operation confirmation / enter the next menu)
	increment key	Increment key (can change group number, index number and parameter value)
	decrement key	Decrement key (can change group number, index number and parameter value)
	menu mode key	Various menu mode switching
	shift key	When setting parameters, move and select the position that needs to be modified
	run key	Start-stop control frequency converter
	stop key	In the running state, it is used to stop the operation; in the fault state, it is used to reset the operation
	multifunction key	Execute actions according to the setting function of parameter F7-02

◆ Parameter mode operation

This series of inverters provides three modes for searching function codes:

(1) Display all function code parameters of the inverter

(2) The user selects and customizes the commonly used function codes, up to 32 can be customized to form a user-defined function code set; the user determines the function parameters to be displayed through the FF group

(3)The frequency converter automatically searches to find out the function codes different from the factory values for users to quickly select;

The three function code display modes can be switched through the <Menu Mode Key> on the panel. When switching to the selected mode, press the <Enter Key> to select it, then enter the menu to view the parameters, and the parameters will be displayed in the selected mode. The various modes are displayed as follows:

Parameter display	Show
All function parameters	- ALL-
User-defined parameters	- -U- -
User changes parameters	- -C- -

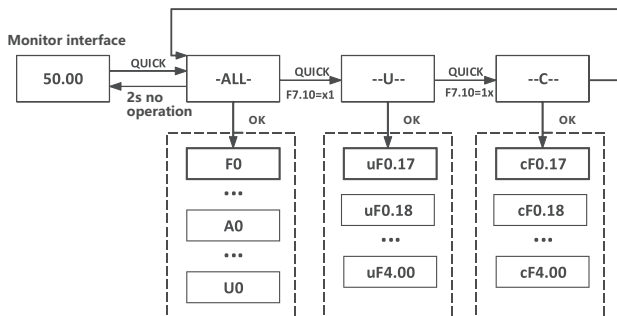

Figure 7.7.3 Menu Mode Operation Selection

◆ parameter settings

The operation panel of the inverter adopts a three-level menu structure for parameter setting and other operations. The third-level menus are: function parameter group (first-level menu) → function code (second-level menu) →function code setting value (third-level menu). The operation process is as follows:

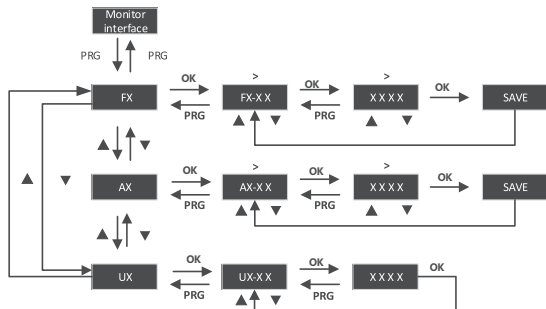

Figure 7.7.4 Parameter setting operation

When operating in the third-level menu, press the PRG key or OK key to return to the second-level menu. The difference between the two is: press the OK key to save the set parameters and return to the second-level menu, and automatically transfer to the next function code; but press the PRG key to abandon the current parameter modification and directly return to the second-level menu of the current function code number. menu.

In the third-level menu state, if the parameter has no flashing bit, it means that the function code cannot be modified, and the possible reasons are as follows:

- 1) This function code is an unmodifiable parameter, such as inverter type, actual detection parameters, operation record parameters, etc.
- 2) This function code cannot be modified in the running state, and can only be modified after the machine is stopped.
- 3) The parameter is protected. F7-11 is set to 1 (all function codes cannot be modified)

## 7.8 Motor self-learning

Please select the most suitable self-learning mode according to the type of motor used, the control mode of the inverter, and the installation environment of the motor.

warn!When dynamic self-learning is selected, the motor will rotate at a speed above 50% of the rated frequency. Please check the surrounding safety.

- ◆ Induction motor self-learning

Before self-learning, please input the motor parameters according to the motor nameplate:

Induction motor self-learning related parameters				
F2-00	Motor Type Selection	0 : Ordinary asynchronous motor 1 : variable frequency asynchronous motor	0	⊙
F2-01	Motor rated power	0.1kW~1000.0kW	Model confirmed	⊙
F2-02	Motor rated voltage	1V~2000V	Model confirmed	⊙
F2-03	Motor rated current	0.01A~655.35A (inverter power≤55kW) 0.1A~6553.5A (inverter power >55kW)	Model confirmed	⊙
F2-04	Motor rated frequency	0.01Hz~ maximum frequency	Model confirmed	⊙
F2-05	Motor rated speed	1rpm~65535rpm	Model confirmed	⊙
Fd-00	Encoder lines	1~65535	1024	⊙
Fd-01	encoder type	0 : ABZ incremental encoder 2 : Resolver	0	⊙
Fd-03	ABZ incremental encoder AB phase sequence	0 : Forward 1 : Reverse	0	⊙
Fd-07	Resolver pole pairs	1~65535	1	⊙

Among them, Fd-00, Fd-01, Fd-03, and Fd-07 are the parameters that need to be set in the control with PG feedback.

Induction motor self-learning mode selection:

Way	Parameter	Conditions of Use	Tuning Effect
Dynamic self-learning	F2-37=2	<ul style="list-style-type: none"> <li>When the motor can be separated from the mechanical load and there is no problem with the motor rotation during self-learning</li> <li>When operating a motor with constant output characteristics</li> <li>When high precision control is required</li> <li>When the motor cannot be separated from the mechanical load, but the load of the motor is less than 30%</li> </ul>	Optimal
Partial static self-learning	F2-37=1	<ul style="list-style-type: none"> <li>When the wiring distance under V/f control is more than 50 m</li> <li>When the motor output and inverter capacity are different</li> </ul>	Generally
Complete static self-learning	F2-37=3	<ul style="list-style-type: none"> <li>When the motor cannot be separated from the mechanical load and the load on the motor exceeds 30%</li> </ul>	Better

◆self-learning steps

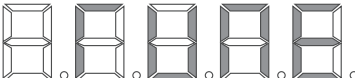
Step	Process
step 1	The inverter operation command is selected as panel operation ( F0-02=0)
step 2	Accurately input the motor nameplate parameters ( F2-00~F2-05)
step 3	Accurately input the encoder parameters (Fd-00 , Fd-01 , Fd-03 , Fd-07) , this step is required for PG control
step 4	Set the motor tuning mode ( F2-37) , press the SET key, the keyboard will display 
step 5	The RUN key on the operation panel , the inverter will drive the motor to run, the running indicator light is on, and the ALM indicator light flashes slowly. The tuning lasts for a period of time, the indicator light goes out, the code displayed on the panel disappears, and it returns to the normal parameter display interface, indicating that the tuning is completed. The inverter will automatically obtain the motor parameter values according to the selected tuning method. Induction motor: Static part parameter tuning: get F2-06 ~ F2-08 parameters Static complete parameter tuning: get F2-06 ~ F2-10 parameters Dynamic complete parameter tuning: get F2-06 ~ F2-10 and Fd-03 parameters Synchronous motor: Static parameter tuning: get F2-16~F2-18 parameters Dynamic parameter tuning: get F2-16~F2-18 and F2-20 parameters

## 7.9 Test run

Set the basic parameters, and start the trial run after the motor self-learning.

warn! Regarding the safety measures when restarting the machine: After the wiring work and parameter setting are completed, be sure to perform a trial run to confirm that the machine can operate safely. There is a risk of death or serious injury if the system is used without a trial run.

### 7.9.1 Trial run under no-load condition

Before connecting the motor to the machine, please confirm the running status of the motor.

Notes before running:

Before operating the motor, please confirm the following items.

- Please confirm the safety around the motor and machinery. Please confirm whether the emergency stop circuit and the safety device on the machine side operate correctly.

Confirmation items at runtime:

Confirm the following items at runtime. Is the motor running forward?

- Whether the rotation of the motor is smooth (whether there is abnormal sound and vibration).
- Whether the acceleration and deceleration of the motor is smooth.

### 7.9.2 no-load operation

The steps of the no-load test run are described below.

- 1) Set F0-08 to 5.00Hz (target operating frequency).
- 2) Press RUN. The running indicator light is on, and the motor rotates forward at 5.00Hz.
- 3) Confirm that the motor rotates in the correct direction, and the inverter has no fault display. If a fault is displayed, remove the cause of the fault.

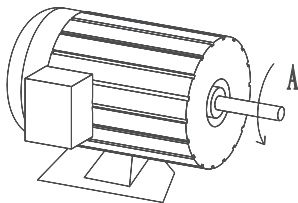

Direction of motor forward rotation: (counterclockwise direction viewed from the load shaft)

- 4) Increase the setting value of F0-08 to increase the operating frequency of the motor. When increasing the operating frequency, please adjust the setting value in steps of 10Hz while checking the responsiveness.
- 5) Press the > shift key, the panel indicator A lights up, and the panel displays the current output current. If the output current of the inverter does not exceed the rated current of the motor, it is in a normal state.
- 6) After confirming that the motor can rotate normally, press STOP. The motor stops and the RUN indicator goes off.

### 7.9.3 Actual load test run

After confirming the operation under no-load condition, connect the motor to the mechanical system and conduct a test run.

Notes before running:

Before running the motor, please confirm the following items:

- Please confirm the safety of the motor and its surroundings.
- Please confirm whether the emergency stop circuit and the safety device on the machine side operate correctly.
- Make sure the motor is completely stopped.
- Please connect the motor and the machine. Please confirm whether the mounting screws are loose, and securely fix the motor shaft and the mechanical system.
- Be prepared to press the stop button at any time in case of abnormal operation.

Confirmation items at runtime:



- Whether the reverse direction of the mechanical action is correct (whether the rotation direction of the motor is correct).

- Whether the acceleration and deceleration of the motor is smooth.

#### 7.9.4 Test run with load

After the motor is connected to the machine, please carry out the test run according to the same operation steps as the no-load.

- Please confirm whether the output current displayed on the panel is too large.

- 1) Set F0-08 to 5.00Hz (target operating frequency).

- 2) Press RUN. The running indicator light is on, and the motor rotates forward at 5.00Hz.

- 3) Confirm that the motor rotates in the correct direction, and the inverter has no fault display. If a fault is displayed, remove the cause of the fault.

- 4) Increase the setting value of F0-08 to increase the operating frequency of the motor. When increasing the operating frequency, please adjust the setting value in steps of 10Hz while checking the responsiveness.

- 5) Press the > Shift key, the indicator A on the right side of the panel is on, and the panel displays the current output current. If the output current of the inverter does not exceed the rated current of the motor, it is in a normal state.

- 6) After confirming that the motor can rotate normally, press STOP. The motor stops and the RUN indicator goes out.

- 7) Change the target frequency and direction of rotation, and check for abnormal sounds and vibrations.

- 8) If there are control failures such as imbalance or vibration, please adjust.

### 7.10 Control Performance Adjustment During Trial Run

Set the basic parameters, and start the trial run after the motor self-learning.

warn! Regarding the safety measures when restarting the machine: After the wiring work and parameter setting are completed, be sure to perform a trial run to confirm that the machine can operate safely. There is a risk of death or serious injury if the system is used without a trial run.

- Induction Motor V/F Control

Fault	Parameter number	Countermeasures	Factory setting	Recommended value
medium speed (10Hz to 40Hz)	F4-11 (Oscillation suppression gain)	Out of adjustment, vibration occurs, increase the set value.	40	0~100
<ul style="list-style-type: none"> <li>■ motor noise</li> <li>■ low speed( less than 10Hz )and medium speed(10Hz to 40 Hz), imbalance and vibration occur</li> </ul>	F0-15 (carrier frequency )	<ul style="list-style-type: none"> <li>■ The motor noise is loud, increase the carrier frequency</li> <li>■ Medium and low speed imbalance, vibration, lower the carrier frequency</li> </ul>	Model confirmed	
low speed ( below 10Hz ).	F4-01 (torque boost )	<ul style="list-style-type: none"> <li>■ The operating parameters have been identified, and automatic torque boost can be set</li> <li>■ No parameter identification, adjust the parameter according to the actual situation</li> </ul>	Model confirmed	0.0% ~ 30.0%
big start shock	F4-01 (torque boost )	<ul style="list-style-type: none"> <li>■ According to the actual situation, lower the parameters</li> <li>■ Execute parameter identification, set to automatic torque boost</li> </ul>	Model confirmed	0.0% ~ 30.0%

Large inertia load, rapid deceleration reports overvoltage	F4-23 (overvoltage stall enable )	Enable overvoltage stall protection function	1	
Poor speed accuracy	F4-09 (slip compensation coefficient )	Adjust this compensation value according to the actual situation	0.0%	0.0% ~ 200.0%

● Induction motor without PG vector control

Fault	Parameter number	Countermeasures	Factory setting	Recommended value
Torque and speed response are slow	Speed loop proportional gain F3-01 (low speed) F3-04 (high speed)	When the response of torque and speed is slow, lower the setting value. When misalignment or vibration occurs, increase the set value	20	1~100
	Speed loop integration time F3-02(low speed) F3-05(high speed)		0.5	0.01~10.00
ASR proportional gain and time cannot be guaranteed at low speed or high speed	F3-03 (speed loop switching frequency 1) F3-06 (speed loop switching frequency 2)	Switch ASR proportional gain and integral time according to output frequency	F3-03 : 5Hz F3-06: 10Hz	Adjust as needed
Large inertia load, rapid deceleration reports overvoltage	F3-23 (generating power limit enabled )	Enable the generating power limit function, and adjust F3-24 and F3-25 as required	0	
Poor speed accuracy	F3-07 (Vector Control Slip Gain )	Adjust this compensation value according to the actual situation	100%	50%~200%
■ motor noise Loss of adjustment and vibration at low speed ( below 3Hz )	F0-15 (carrier frequency)	■ The motor noise is loud, increase the carrier frequency ■ Low-speed imbalance, vibration, lower the carrier frequency	Model confirmed	

- Induction motor with PG vector control

Fault	Parameter number	Countermeasures	Factory setting	Recommended value
Torque and speed response are slow	Speed loop proportional gain F3-01 (low speed) F3-04 (high speed)	When the response of torque and speed is slow, lower the setting value. When misalignment or vibration occurs, increase the set value	20	1~100
	Speed loop integration time F3-02 (low speed) F3-05 (high speed)		0.5	0.01~10.00
ASR proportional gain and time cannot be guaranteed at low speed or high speed	F3-03 (speed loop switching frequency 1) F3-06 (speed loop switching frequency 2)	Switch ASR proportional gain and integral time according to output frequency	F3-03 : 5Hz F3-06: 10Hz	Adjust as needed
■ motor noise Loss of adjustment and vibration at low speed ( below 3Hz )	F0-15 (carrier frequency)	<ul style="list-style-type: none"> <li>■ The motor noise is loud, increase the carrier frequency</li> <li>■ Low-speed imbalance, vibration, lower the carrier frequency</li> </ul>	Model confirmed	

### 7.11 Checklist for test run

During the trial run, please follow the steps below to confirm:

(1) before the first test run

Test	Serial number	Content
	1	Whether the correct installation and wiring are completed according to the specifications
	2	Is the mechanical load connected to the motor shaft disconnected?
	3	Whether the motor shaft can rotate
	4	Whether the inverter has been set with automatic start function
	5	Is the power of the inverter connected?

(2) first test run

Test	Serial number	Content
	1	Whether the "heavy load or light load" model setting is completed according to the load characteristics
	2	Whether to set the motor parameters
	3	Is it appropriate to reduce the operating frequency, such as 10Hz
	4	Whether the inverter can start normally
	5	Whether the motor is rotating and whether the direction of the motor is correct any two phase cables of U/V/W
	6	Whether to complete the motor parameter self-learning

## 8 Repair, Maintenance and Storage Precautions

Due to the influence of the temperature, humidity, dust and vibration of the environment, the aging and wear of the components inside the frequency converter, etc., many reasons will lead to potential failures of the frequency converter. Therefore, it is necessary to implement daily and regular maintenance and maintenance of the frequency converter.

Note: Before inspection and maintenance, please confirm the following items first, otherwise there may be a risk of electric shock:

- (1) The inverter has cut off the power supply;
- (2) After the cover is opened, the charging indicator light goes out;
- (3) Use a DC high voltage meter to measure the voltage between the DC busbars to be less than 36V.

### 8.1 Daily maintenance

In principle, the daily inspection checks whether there is any abnormality during operation:

- 1) Whether the motor runs according to the setting;
- 2) Whether the environment of the installation site is abnormal;
- 3) Whether the cooling system is abnormal;
- 4) Is there any abnormal vibration sound;
- 5) Whether there is overheating and discoloration;
- 6) Use a multimeter to measure the input voltage of the inverter during operation.

### 8.2 Regular inspection and maintenance

According to the use environment, the user can conduct a regular inspection of the inverter every 3 months or 6 months.

During the regular maintenance and inspection of the inverter, be sure to cut off the power supply. After the monitor (keyboard) has no display and the main circuit power indicator light goes out for 10 minutes, use a multimeter to detect  $\oplus$ ,  $\ominus$  DC bus voltage is less than 25V before checking, so as to avoid the residual voltage of the capacitor of the inverter from hurting the maintenance personnel.

- (1) Cooling system: Please clean the air filter and check whether the cooling fan is normal.
- (2) Screws and bolts: Due to vibration, temperature changes, etc., fixed parts such as screws and bolts may become loose. Check whether they are tightened reliably, and please tighten them according to the tightening torque.
- (3) Check whether the conductor and insulator substances are corroded and damaged.
- (4) Measure the insulation resistance.
- (5) Check the filter capacitor for discoloration, peculiar smell, bubbling, leakage, etc.

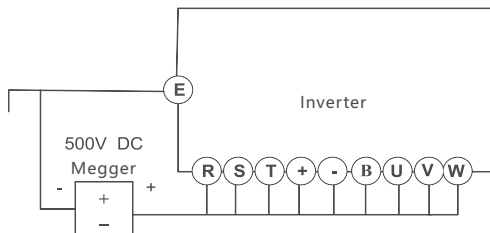

Figure 8.2.1 Main circuit insulation resistance test

The inverter must operate in accordance with the specified operating environment, and some unexpected situations may occur during operation. The user should follow the tips in the table below to do daily maintenance work. It is a good way to prolong the service life of the inverter to maintain a good operating environment, record the data of daily operation, and find out the cause of the abnormality early.

Table 8.2.1 Tips for Daily Inspection

Inspection object	Check essentials			Criterion
	Check content	cycle	Means of inspection	
Operating environment	1. Temperature humidity	At any time	1. Thermometer, Hygrometer	1. (-10~+45) °C , (45~55) °C derating use
	2. Dust, water and drip		2. Visually	2. No trace of water leakage
	3. Gas		3. The sense of smell	3. Odorless
Inverter	1. Vibration, heat	At any time	1. Shell touch	1. Stable vibration and reasonable fan temperature
	2. Noise		2. Hearing	2. No abnormal sound
Motor	1. Fever	At any time	1. Hand touch	1. Fever without abnormality
	2. Noise		2. Hearing	2. Uniform noise
Running state parameters	1. Output current	At any time	1. Ammeter	1. In the rated range
	2. The output voltage		2. Voltmeter	2. In the rated range
	3. Internal temperature		3. Thermometer	3. Temperature rise is less than 35K

### 8.3 Replace wearing parts

Vulnerable parts of frequency converter mainly include cooling fan and electrolytic capacitor for filtering, and their service life is closely related to the environment of use and maintenance status. Typical life times are shown in the table below.

Table 8.3.1 Component life

Device name	Life time
Fan	( 3 ~ 4 ) million hours
Electrolytic capacitor	( 4 ~ 5 ) million hours
Relay	About 100,000 times

Users can determine the replacement period according to the running time.

#### (1) Cooling fan

Possible causes of damage: bearing wear, blade aging.

Judgment criteria: Whether there are cracks in the fan blades, etc., and whether there is abnormal vibration sound when the machine is turned on.

#### (2) Filter electrolytic capacitor

Possible damage reasons: high ambient temperature, frequent load jumps cause increased pulsating current, and electrolyte aging.

Judgment criteria: whether there is liquid leakage, whether the safety valve has protruded, the measurement of electrostatic capacitance, and the measurement of insulation resistance.

#### (3) Relay

Possible causes of damage: corrosion, frequent movement.

Judgment criteria: open and close failure.

### 8.4 Storage period and precautions

After purchasing the inverter, users must pay attention to the following points for temporary storage and long-term storage:

(1) Avoid storing in high temperature, humidity and places rich in dust and metal dust, and ensure good ventilation;

(2) A power-on test must be carried out within 2 years for long-term stored inverters. When powering on, use a voltage regulator to slowly increase to the rated value, and power on for 1 hour without load.

## 9 Fault Analysis and Elimination

The following fault types may be encountered during the use of the inverter, please refer to the following methods for simple fault analysis:

**Table 9.1.1 Common Fault Codes and Troubleshooting Methods of Inverter**

Fault name	Panel display	Troubleshooting	Troubleshooting
Acceleration overcurrent	E.OC1 (fault value 02)	There is a grounding or short circuit in the output circuit of the inverter	<ul style="list-style-type: none"> <li>Eliminate peripheral faults and detect whether there is a short circuit in the motor or interrupt contactor</li> </ul>
		The control mode is FVC or SVC and no parameter identification is performed	<ul style="list-style-type: none"> <li>Set the motor parameters according to the motor nameplate, and carry out motor parameter identification</li> </ul>
		Under rapid acceleration conditions, the acceleration time is set too short	<ul style="list-style-type: none"> <li>Increase acceleration time</li> </ul>
		Inappropriate overflow stall suppression setting	<ul style="list-style-type: none"> <li>Confirm that the overflow stall suppression function (F4-19) has been enabled;</li> <li>Overcurrent stall action current(F4-18) setting value is too large, recommended at 120% arrive 150% internal adjustment;</li> <li>Overflow stall suppression gain (F4-20) is set too small, it is recommended to set 20 to 40 internal adjustment;</li> </ul>
		Manual torque boost or V/F curve is not suitable	<ul style="list-style-type: none"> <li>Adjust manual lifting torque or V/F curve</li> </ul>
		Start a spinning motor	<ul style="list-style-type: none"> <li>Select speed tracking start or wait for the motor to stop before starting</li> </ul>
		Subject to external interference	<ul style="list-style-type: none"> <li>View historical fault records, if the fault occurs</li> </ul> <p>The current value is far from the over-current point value, and it is necessary to find the source of interference. If there are no other sources of interference, it may be a problem with the driver board or the Hall device.</p>
Deceleration overcurrent	E.OC2 (fault value 03)	There is a grounding or short circuit in the output circuit of the inverter	<ul style="list-style-type: none"> <li>Eliminate peripheral faults and detect whether the motor is short-circuited or open-circuited</li> </ul>
		The control method is FVC or SVC without parameter identification	<ul style="list-style-type: none"> <li>Set the motor parameters according to the motor nameplate to identify the motor parameters</li> </ul>
		In the case of rapid deceleration, the deceleration time is set too short	<ul style="list-style-type: none"> <li>increase deceleration time</li> </ul>

Deceleration overcurrent	E.OC2 (fault value 03)	Inappropriate overflow stall suppression setting	<ul style="list-style-type: none"> <li>Confirm that the overflow stall suppression function (F4-19) has been enabled;</li> <li>Overcurrent stall action current(F4-18) setting value is too large, recommended at 120% arrive 150% internal adjustment;</li> <li>Overflow stall suppression gain(F4-20) is set too small, it is recommended to set 20 to 40 internal adjustment;</li> </ul>
		No braking unit and braking resistor installed	<ul style="list-style-type: none"> <li>Add brake unit and resistor</li> </ul>
		subject to external interference	<ul style="list-style-type: none"> <li>Check the historical fault records. If the current value is far from the overcurrent point value at the time of the fault, you need to find the source of interference. If there are no other sources of interference, it may be a problem with the driver board or the Hall device.</li> </ul>
Constant speed overcurrent	E.OC3 (fault value 04)	There is a grounding or short circuit in the output circuit of the inverter	<ul style="list-style-type: none"> <li>Eliminate peripheral faults and detect whether the motor is short-circuited or open-circuited</li> </ul>
		The control method is FVC or SVC without parameter identification	<ul style="list-style-type: none"> <li>Set the motor parameters according to the motor nameplate to identify the motor parameters</li> </ul>
		Inappropriate overflow stall suppression setting	<ul style="list-style-type: none"> <li>Confirm that the overflow stall suppression function (F4-19) has been enabled;</li> <li>Overcurrent stall action current(F4-18) setting value is too large, recommended at 120% arrive 150% internal adjustment;</li> <li>Overflow stall suppression gain (F4-20) is set too small, it is recommended to set 20 to 40 internal adjustment;</li> </ul>
		Inverter selection is too small	<ul style="list-style-type: none"> <li>In a stable running state, if the running current has exceeded the rated current of the motor or the rated output current of the inverter, please choose an inverter with a higher power rating.</li> </ul>
		subject to external interference	<ul style="list-style-type: none"> <li>Check the historical fault records. If the current value is far from the overcurrent point value at the time of the fault, you need to find the source of interference. If there are no other sources of interference, it may be a problem with the driver board or the Hall device.</li> </ul>

Accelerated overvoltage	E.OU1 (fault value 05)	Input voltage is too high During the acceleration process, there is an external force to drive the motor to run	<ul style="list-style-type: none"> <li>Adjust the voltage to the normal range</li> <li>Cancel the external power or install braking resistor</li> </ul>
		Inappropriate overvoltage suppression setting	<ul style="list-style-type: none"> <li>Confirm that the overvoltage suppression function (F4-23) has been enabled;</li> <li>Overvoltage suppression action voltage (F4-22) setting value is too large, it is recommended to be 770V~700V internal adjustment;</li> <li>The setting of overvoltage suppression gain (F4-24) is too small, it is recommended to set 30 adjustwithin 50;</li> </ul>
		No braking unit and braking resistor installed	<ul style="list-style-type: none"> <li>Add brake unit and resistor</li> </ul>
		Acceleration time is too short	<ul style="list-style-type: none"> <li>Increase acceleration time</li> </ul>
Deceleration overvoltage	E.OU2 (fault value 06)	Inappropriate overvoltage suppression setting	<ul style="list-style-type: none"> <li>Confirm that the overvoltage suppression function (F4-23) has been enabled;</li> <li>The setting value of the overvoltage suppression operating voltage (F4-22) is too large, it is recommended to 770V~700V internal adjustment;</li> <li>The setting of overvoltage suppression gain (F4-24) is too small, it is recommended to set 30 to 50 internal adjustment;</li> </ul>
		During the deceleration process, there is an external force to drive the motor to run	<ul style="list-style-type: none"> <li>Cancel external power or add braking resistor</li> </ul>
		Deceleration time is too short	<ul style="list-style-type: none"> <li>Increase deceleration time</li> </ul>
		No braking unit and braking resistor installed	<ul style="list-style-type: none"> <li>Add brake unit and resistor</li> </ul>
Constant speed overvoltage	E.OU3 (fault value 07)	Inappropriate overvoltage suppression setting	<ul style="list-style-type: none"> <li>Confirm that the overvoltage suppression function (F4-23) has been nenabled;</li> <li>The setting value of the overvoltage suppression operating voltage (F4-22) is too large, it is recommended to 770V~700V internal adjustment;</li> <li>The setting of overvoltage suppression frequency gain (F4-24) is too small, it is recommended to set 30 to 50 internal adjustment;</li> <li>Overvoltage suppression maximum rising frequency (F4-26) setting is too small, recommended exist 5~20Hz internal adjustment;</li> </ul>



Constant speed overvoltage	E.OU3 (fault value 07)	During the operation, there is an external force to drive the motor to run	<ul style="list-style-type: none"> <li>Cancel the external power or install braking resistor</li> </ul>
Buffer power failure	E.RES (fault value 08)	The bus voltage fluctuates up and down at the undervoltage point	<ul style="list-style-type: none"> <li>Seek technical support</li> </ul>
Undervoltage fault	E.UV (fault value 09)	Momentary power failure	<ul style="list-style-type: none"> <li>Enable the function of instantaneous power failure and non-stop function (FE-59 ), which can prevent instantaneous power failure and undervoltage fault</li> </ul>
		The voltage at the input terminal of the inverter is not within the range required by the specification	<ul style="list-style-type: none"> <li>Adjust the voltage to the normal range</li> </ul>
		Bus voltage is abnormal	<ul style="list-style-type: none"> <li>Seek technical support</li> </ul>
		The rectifier bridge, snubber resistor, drive board, and control board are abnormal	<ul style="list-style-type: none"> <li>Seek technical support</li> </ul>
Inverter overload	E.OL2 (fault value 10)	Whether the load is too large or the motor is blocked	<ul style="list-style-type: none"> <li>Reduce load and check motor and mechanical condition</li> </ul>
		Inverter selection is too small	<ul style="list-style-type: none"> <li>Choose a frequency converter with a higher power rating</li> </ul>
Motor overload	E.OL1 (fault value 11)	Motor Protection Parameters FE-01 Is the setting appropriate?	<ul style="list-style-type: none"> <li>Set this parameter correctly</li> </ul>
		Whether the load is too large or the motor is blocked	<ul style="list-style-type: none"> <li>Reduce load and check motor and mechanical condition</li> </ul>
Input phase loss	E.SPI (fault value 12)	Three-phase input power is abnormal	<ul style="list-style-type: none"> <li>Check and eliminate the problems existing in the peripheral circuit</li> </ul>
		The drive board, lightning protection board, main control board, and rectifier bridge are abnormal	<ul style="list-style-type: none"> <li>Seek technical support</li> </ul>
Output phase loss	E.SPO (fault value 13)	Motor failure	<ul style="list-style-type: none"> <li>Detect whether the motor is broken</li> </ul>
		The lead wire from the inverter to the motor is abnormal	<ul style="list-style-type: none"> <li>Troubleshooting Peripherals</li> </ul>
		The three-phase output of the inverter is unbalanced when the motor is running	<ul style="list-style-type: none"> <li>Check whether the three-phase winding of the motor is normal and troubleshoot</li> </ul>
		Driver board, IGBT module exception	<ul style="list-style-type: none"> <li>Seek technical support</li> </ul>
module overheating	E.OH1 (fault value 14)	Ambient temperature is too high	<ul style="list-style-type: none"> <li>Reduce ambient temperature</li> </ul>
		Duct blockage	<ul style="list-style-type: none"> <li>Clean up the air duct</li> </ul>
		Fan damage	<ul style="list-style-type: none"> <li>Replace the fan</li> </ul>
		The module thermistor is damaged	<ul style="list-style-type: none"> <li>Seek manufacturer service</li> </ul>
		The inverter module is damaged	<ul style="list-style-type: none"> <li>Seek manufacturer service</li> </ul>

External device failure	E.EF (fault value 15)	via the multi-function terminal X Input signal for external fault	<ul style="list-style-type: none"> <li>Check the peripheral faults , confirm that the machine is allowed to restart (F8-18 ) , and reset the operation</li> </ul>
		through virtual IO Function input signal for external fault	<ul style="list-style-type: none"> <li>Confirm A0 Group virtual IO Group parameter setting is correct, reset operation</li> </ul>
Communication fail	E.CE (fault value 16)	The upper computer is not working properly	<ul style="list-style-type: none"> <li>Check the upper computer wiring</li> </ul>
		The communication line is abnormal	<ul style="list-style-type: none"> <li>Check the communication cable</li> </ul>
		communication expansion card Fb-00 incorrect settings	<ul style="list-style-type: none"> <li>Correctly set the communication expansion card type</li> </ul>
		Communication parameters Fb Incorrect group settings	<ul style="list-style-type: none"> <li>Correctly set communication parameters</li> </ul>
		After the above tests are completed, the fault still cannot be eliminated, you can try to restore the factory settings.	
Contactor failure	E.SHT (fault value 17)	Abnormal drive board and power supply	<ul style="list-style-type: none"> <li>Seek manufacturer service</li> </ul>
		Abnormal contactor	<ul style="list-style-type: none"> <li>Seek manufacturer service</li> </ul>
		Abnormal lightning protection board	<ul style="list-style-type: none"> <li>Seek manufacturer service</li> </ul>
Current sense failure	E.ITE (fault value 18)	Check Hall device abnormality	<ul style="list-style-type: none"> <li>Seek manufacturer service</li> </ul>
		Abnormal drive board	<ul style="list-style-type: none"> <li>Seek manufacturer service</li> </ul>
Motor tuning failure	E.TE (fault value 19)	The motor parameters are not set according to the nameplate	<ul style="list-style-type: none"> <li>Correctly set the encoder type according to the actual situation</li> </ul>
		Parameter identification process timed out	<ul style="list-style-type: none"> <li>Check the lead wires from the inverter to the motor</li> </ul>
			<ul style="list-style-type: none"> <li>Check whether the encoder line number setting is correct Fd-00 , check the encoder Is the signal line connected correctly and securely?</li> </ul>
Encoder failure	E.ENCD (fault value 20)	Encoder model does not match	<ul style="list-style-type: none"> <li>Correctly set the motor parameters according to the nameplate</li> </ul>
		Encoder connection error	<ul style="list-style-type: none"> <li>detection PG Card Power and Phase Sequence</li> </ul>
		Encoder damaged	<ul style="list-style-type: none"> <li>Replace the encoder</li> </ul>
		PG Card exception	<ul style="list-style-type: none"> <li>Replace PG Card</li> </ul>
EEPROM Read and write failure	E.EEP (fault value 21)	EEPROM chip damage	<ul style="list-style-type: none"> <li>Seek manufacturer service</li> </ul>
Short circuit fault to ground	E.STG (fault value 23)	Motor short circuit to ground	<ul style="list-style-type: none"> <li>Replace cable or motor</li> </ul>
Cumulative running time reached fault	E.RTO (fault value 26)	The cumulative running time reaches the set value	<ul style="list-style-type: none"> <li>Use the parameter initialization function to clear the record information</li> </ul>

User-Defined Fault 1	E.US1 (fault value 27)	via the multi-function terminal X Enter user-defined faults 1 signal of	• Reset operation
		through virtual IO Function Input User Defined Fault 1 signal of	• Reset operation
User-Defined Fault 2	E.US2 (fault value 28)	via the multi-function terminal X Enter user-defined faults 2 signal of	• Reset operation
		through virtual IO Function Input User Defined Fault 2 signal of	• Reset operation
load drop fault	E.LL (fault value 30)	The operating current of the inverter is less than FE-67	• Confirm whether the load is disengaged or FE-67, FE-68 Whether the parameter setting conforms to the actual operating conditions
Runtime PIDs Feedback loss failure	E.FBL (fault value 31)	PIDs Feedback is less than F9-26 set value	• examine PIDs Feedback signal or setting F9-26 for a suitable value
Wave-by-wave current limiting fault	E.CBC (fault value 40)	Whether the load is too large or the motor is blocked	• Reduce load and check motor and mechanical condition
		Inverter selection is too small	• Choose a frequency converter with a higher power level
Excessive speed deviation fault	E.DEV (fault value 42)	Encoder parameter setting is incorrect	• Correctly set the encoder parameters
		No parameter identification	• Perform motor parameter identification
		Unreasonable setting of detection parameters FE-72 and FE-73 for excessive speed deviation	• Reasonably set the detection parameters according to the actual situation
Motor overspeed fault	E.OS (fault value 43)	Encoder parameter setting is incorrect	• Correctly set the encoder parameters
		No parameter identification	• Perform motor parameter identification
		Motor overspeed detection parameters FE-70, FE-71 settings are unreasonable	• Reasonably set the detection parameters according to the actual situation
Motor over temperature fault	E.OH2 (fault value 45)	Temperature sensor wiring is loose	• Detect temperature sensor wiring and troubleshoot
		Motor temperature is too high	• Increase the carrier frequency or take other heat dissipation measures to dissipate heat from the motor
Initial position detection error	E.POS (fault value 51)	using synchronous motor SVC vector control, the wiring from the inverter to the motor is incorrect	• Detect the inverter output wiring
Master-slave control slave failure	E.P2P (fault value 55)	The slave machine fails, check the slave machine	• Troubleshoot according to the fault code of the slave
Brake unit overload	E.BOL (fault value 61)	The value of braking resistor is too small	• Please refer to < Brake component selection table>
Brake circuit short circuit	E.BSH (fault value 62)	Abnormal braking module	• Seek technical support

## **10 Warranty period and environmental protection and other legal regulations**

### **10.1 Warranty**

Under normal storage and transportation conditions and the product packaging is intact or the product itself is intact, the warranty period is 12 months from the date of purchase by the user or 18 months from the date of production, whichever comes first.

The following situations are not covered by the warranty:

- 1) Damage caused by improper use, storage and maintenance by the user;
- 2) Damage caused by organizations or personnel not appointed by the company, or self-disassembly and maintenance;
- 3) The product exceeds the warranty period;
- 4) Damage caused by force majeure;
- 5) When the barcode, nameplate and other marks marked by the manufacturer on the product are damaged or unrecognizable;
- 6) When the user fails to pay off the purchase price according to the "Purchase and Sales Contract" signed by both parties;
- 7) When the user deliberately conceals the improper use of the product during installation, wiring, operation, maintenance or other processes from the after-sales service provider of the manufacturer.
- 8) For products that have failed, the company has the right to entrust others to maintain the warranty, and the relevant service fees are calculated according to the actual costs. If there is an agreement, the principle of priority shall be given to the agreement.
- 9) The company's sales and agencies in China can provide after-sales services for this product.

### **10.2 Environmental protection**

In order to protect the environment, when this product or its parts are scrapped, please dispose of it properly as industrial waste; or hand it over to a recycling station for classification, dismantling, recycling, etc. in accordance with relevant national regulations.

## 11 Product Selection and Ordering Instructions

### 11.1 Heavy Duty Rating vs Light Duty Rating

NVF3 series inverters can meet two load applications of heavy load (T type) and light load (P type). The main differences between heavy-load applications and light-load applications are shown in the table below.

**Table 11.1.1 Heavy duty rating (T type) and light duty rating (P type)**

Load	Corresponding torque characteristics	Common load	Overload capacity	Parameter setting
overload	Constant torque	extruder conveyor belt Cranes - lifting,translation Other constant torque or high overload applications	150% heavy load rated current, 60 seconds 1 overload allowed every 10 minutes	F0-00=1
light load	variable torque	fan water pump Other variable torque or light load applications	110% light load rated current, 60 seconds Overload allowed every 10 minutes	F0-00=2

### 11.2 Derating of frequency converter

When selecting and using the product, please determine whether derating is required according to the actual usage. Derating is mainly considered in the following cases:

- ◆ Ambient temperature and derating use

When the ambient temperature exceeds 40°C, derating is required, and the derating is 1.5% for every 1°C increase in the ambient temperature, and the maximum operating ambient temperature is 50°C.

- ◆ Altitude and Derating

In areas where the altitude exceeds 1000m, the heat dissipation effect of the inverter is deteriorated due to the thin air, so it is necessary to derate the use (for every 100m increase in altitude, derate 1%, and the maximum operating altitude is 3000m.)

- ◆ Parallel and Derating

When multiple inverters are paralleled and installed compactly (the interval between two inverters is less than 5mm), they need to be used with 70%-80% derating according to the actual application environment. Please consult our company for details.

### 11.3 Main circuit peripheral device selection

In the application of frequency converter products, reasonable selection of suitable peripheral devices for the main circuit plays an important role in the reliable operation of the product. For the selection of peripheral components of the main circuit, please refer to the product selection catalog of our company. For details, please consult the agent dealer or sales manager.

**Table 11.3.1 Peripheral device types of the main circuit**

Name	Model	Describe
breaker	universal	The time characteristics of the circuit breaker should fully consider the time characteristics of the inverter overload protection, the capacity of the circuit breaker is 1.2~2 times the rated current of the inverter; In order to avoid the grid impact caused by short circuit at the output end of the inverter or internal fault, a circuit breaker must be installed at the input end of the inverter.
contactor	universal	In order to ensure safety, please use a contactor, but do not use the contactor to control the start and stop of the inverter. Frequent closing and disconnection of the contactor will reduce the life of the inverter.
Input AC Reactor	ACL series	<p>When the following situations occur, please connect an AC reactor to the input end of the inverter or install a DC reactor on the DC reactor terminal</p> <ol style="list-style-type: none"> <li>1. The power supply of the inverter is greater than 600kVA or the capacity of the power supply is greater than 10 times the capacity of the inverter;</li> <li>2. If there is a switch-type reactive power compensation capacitor or a thyristor phase-controlled load on the same power node, a large peak current will flow into the input power circuit, which will cause damage to the rectifier part;</li> <li>3. When the voltage imbalance of the three-phase power supply of the inverter exceeds 3%, it will cause damage to the rectifier part;</li> <li>4. The input power factor of the inverter is required to be greater than 90%.</li> </ol>
Input Noise Filter	universal	It can reduce the noise of the frequency converter from the input end of the power supply, and also reduce the noise from the output of the frequency converter to the power supply end.
DC reactor	DCL series	<p>When the following situations occur, please connect an AC reactor to the input end of the inverter or install a DC reactor on the DC reactor terminal</p> <ol style="list-style-type: none"> <li>1. The power supply of the inverter is greater than 600kVA or the capacity of the power supply is greater than 10 times the capacity of the inverter;</li> <li>2. If there is a switch-type reactive power compensation capacitor or a thyristor phase-controlled load on the same power node, a large peak current will flow into the input power circuit, which will cause damage to the rectifier part ;</li> <li>3. When the voltage imbalance of the three-phase power supply of the inverter exceeds 3%, it will cause damage to the rectifier part;</li> <li>4. The input power factor of the inverter is required to be greater than 90%.</li> </ol>
output noise filter	universal	Connecting a noise filter to the output of the frequency converter can reduce conduction and radiation interference.

Output AC Reactor	OCL series	When the connecting line from the inverter to the motor exceeds 100 meters, it is recommended to install an AC output reactor that can suppress high-frequency oscillation to avoid motor insulation damage, excessive leakage current and frequent protection of the inverter.
output noise filter	universal	Connecting a noise filter to the output of the frequency converter can reduce conduction and radiation interference.
External braking unit	universal	Medium and high-power inverters without built-in braking units, or multiple inverters share a DC bus, and the load motor has relatively large feedback energy.
Braking resistor	universal	The mechanical energy in the braking process of the motor can be consumed in the form of heat energy through the braking resistor, which can shorten the deceleration time of the drive system of the inverter.

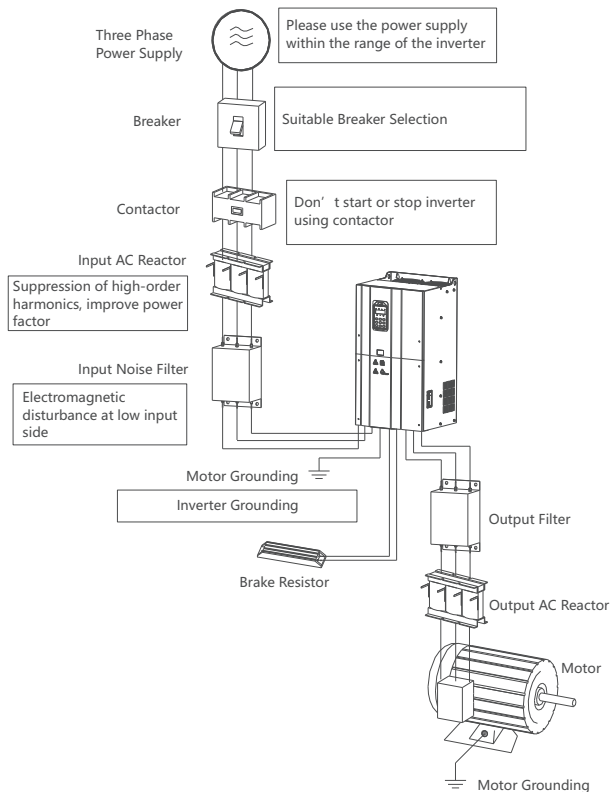
**Figure 11.3.1 Peripheral components of the main circuit**

## 12 Detailed parameters

### 12.1 F0 group basic functions

F0-00	TP type setting	Factory default	1	Attributes	<input type="radio"/>
	Predetermined area	1	T type (constant torque load model)		
		2	P type (fan, water pump load type)		

This parameter can be changed in the stop state. After modifying this parameter, the related parameters of inverter model and motor will be modified automatically.

F0-01	1st motor control method	Factory default	0	Attributes	<input type="radio"/>
	Predetermined area	0	Speed sensorless vector control (SVC)		
		1	Vector control with speed sensor (FVC)		
		2	V/F control		

0: Speed sensorless vector control is suitable for high-performance control occasions.

1: For vector control with speed sensor, an encoder must be installed at the motor end, and the inverter must be equipped with a PG card of the same type as the encoder. It is suitable for occasions of high-precision speed control or torque control.

2: V/F control is suitable for occasions where the load requirements are not high, or where one inverter drives multiple motors, such as fan and pump loads.

F0-02	Run command selection	Factory default	0	Attributes	<input type="radio"/>
	Predetermined area	0	Operator panel commands		
		1	Terminal command		
		2	communication command		

When the operation panel command is selected, the LOC/REM indicator is off; when the terminal command is selected, the LOC/REM indicator is on; when the communication command is selected, the LOC/REM indicator flashes.

F0-03	Main frequency X instruction selection	Factory default	0	Attributes	<input type="radio"/>
	Predetermined area	0	Digital setting (no memory when power off)		
		1	Digital setting (power-down memory)		
		2	AI1		
		3	AI2		
		4	AI3		
		5	Pulse Setting ( HDI )		
		6	multi-segment command		
		7	Simple PLC		
		8	PID		
9	Communication given				

0: digital setting (no memory when power off)

The initial value of the set frequency is the value of F0-08 "preset frequency". The set frequency value of the inverter can be modified through the ▲ and ▼ keys of the keyboard (or UP and DOWN of the multi-function input terminal). When the inverter is powered off and powered on again, the set frequency value will return to the value of F0-08 "digital setting preset frequency".



**1: Digital setting (power-down memory )**

The initial value of the set frequency is the value of F0-08 "preset frequency". The set frequency value of the inverter can be modified through the ▲ and ▼ keys of the keyboard (or UP and DOWN of the multi-function input terminal). When the inverter is powered off and powered on again, the set frequency value is the modified value.

2: AI1

3: AI2

4: AI3

The frequency is given through the analog input terminal.

5: Pulse given (HDI)

The frequency is given through the terminal HDI high-speed pulse. Pulse given signal specifications: voltage range 9V~30V, frequency range 0kHz~100kHz.

The relationship between the HDI terminal input pulse frequency and the corresponding setting is set through F5-28~F5-31. The 100.0% corresponding to the pulse input setting refers to the percentage relative to the maximum frequency F0-10.

**6: Multi-segment instructions**

When selecting the multi-segment command operation mode, it is necessary to input different state combinations of the digital input X terminals to correspond to different set frequency values. It can set 4 multi-segment command terminals, 16 states of 4 terminals, and can correspond to any 16 "multi-segment commands" through the function code of group FA. "Multi-segment command" is the percentage relative to the maximum frequency F0-10.

**7: Simple PLC**

When the frequency source is simple PLC, the operating frequency of the inverter can be switched between 1~16 arbitrary frequency commands. The holding time of 1~16 frequency commands and the respective acceleration and deceleration times can also be set by the user. For details, refer to Instructions for the FA group.

**8: PID**

Process PID control is a common method of process control. By performing proportional, integral and differential operations on the difference between the feedback signal of the controlled quantity and the target signal, the output frequency of the inverter is adjusted to form a closed-loop system to stabilize the controlled quantity, at the target value. When using PID as the frequency source, it is necessary to set the relevant parameters of Group F9 "PID function".

**9: Communication setting**

When the communication setting is used as the frequency source, it is necessary to set the Fb group communication related parameters.

F0-04	Auxiliary frequency Y command selection	Factory default	0	Attributes	⊙
	Predetermined area	0	Digital setting (no memory when power off )		
1		Digital setting (power-down memory )			
2		AI1			
3		AI2			
4		AI3			
5		Pulse Setting ( HDI)			
6		multi-segment command			
7		Simple PLC			
8		PID			
9		Communication given			

When the auxiliary frequency source is used as an independent frequency given channel (that is, the frequency source is selected to switch from X to Y), its usage is the same as that of the main frequency source X, and the usage can refer to the relevant instructions of F0-03.

F0-05	Auxiliary frequency command range selection		Factory default	0	Attributes	<input type="radio"/>
	Predetermined area	0	relative to the maximum frequency			
		1	Relative to main frequency source X			
F0-06	Auxiliary frequency command range		Factory default	100%	Attributes	<input type="radio"/>
	Predetermined area		0% ~ 150%			

When the auxiliary frequency source is given by analog input (AI1, AI2, AI3) or pulse input, 100% of the input setting corresponds to the range of the auxiliary frequency source, which can be set through F0-05 and F0-06. If F0-05 is selected to be relative to the maximum frequency, 100% of the auxiliary frequency corresponds to F0-10; if it is selected to be relative to the main frequency source, the range of the auxiliary frequency source will change with the change of the main frequency X.

F0-07	Main and auxiliary frequency superposition selection		Factory default	0	Attributes	<input type="radio"/>	
	Predetermined area	ones place	Frequency source selection				
		0	Main frequency source X				
		1	Primary and secondary operation results (the operation relationship is determined by tens)				
		2	Switch between main frequency source X and auxiliary frequency source Y				
		3	Switch between the main frequency source X and the main and auxiliary calculation results				
		4	Auxiliary frequency source Y and switching between main and auxiliary calculation results				
		ten	Main and auxiliary frequency calculation relationship				
		0	main + auxiliary				
		1	primary-secondary				
		2	Maximum of both				
3	Minimum of both						

The frequency setting is realized through the combination of the main frequency source X and the auxiliary frequency source Y. The combination method is shown in the figure below:

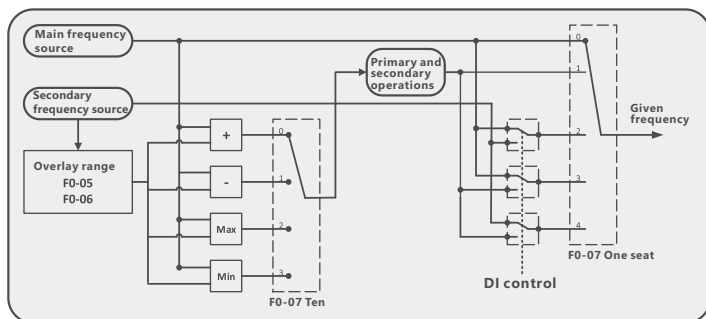

F0-08	preset frequency	Factory default	50.00Hz	Attributes	<input type="radio"/>
	Predetermined area	0.00Hz ~ F0.10 maximum frequency			

When the frequency source is selected as "digital setting", the value of this function code is the initial value of frequency digital setting of the inverter.

F0-09	Running direction	Factory default	0	Attributes	<input type="radio"/>
	Predetermined area	0	run in default direction		
		1	Run in the opposite direction from the default		

By changing this function code, the forward rotation direction of the motor can be adjusted without modifying the wiring of the motor.

Note: After the parameters are initialized, the running direction of the motor will return to the original state. It should be used with caution in occasions where it is strictly forbidden to change the direction of the motor after the system has been debugged.

F0-10	maximum frequency	Factory default	50.00Hz	Attributes	<input checked="" type="radio"/>
	Predetermined area	50.00Hz ~ 500.00Hz			

The actual frequency value corresponding to the frequency setting 100.0% .

F0-11	upper limit frequency source	Factory default	0	Attributes	<input checked="" type="radio"/>
	Predetermined area	0	F0-12 setting		
		1	AI1		
		2	AI2		
		3	AI3		
		4	PULSE setting (HDI)		
5	communication settings				

When the inverter runs to the upper limit frequency value, the inverter will keep running at the upper limit frequency

F0-12	upper limit frequency	Factory default	50.00Hz	Attributes	<input type="radio"/>
	Predetermined area	F0-14 (lower limit frequency) ~ F0-10 (maximum frequency)			
F0-13	Upper limit frequency offset	Factory default	0.00Hz	Attributes	<input type="radio"/>
	Predetermined area	0.00Hz~ F0-10 (maximum frequency)			
F0-14	lower limit frequency	Factory default	0.00Hz	Attributes	<input type="radio"/>
	Predetermined area	0.00Hz ~ F0-12 (upper limit frequency)			

Upper limit frequency: When the set frequency of the inverter is higher than the upper limit frequency, the inverter will run at the upper limit frequency.

Upper limit frequency offset: When the upper limit frequency source is set to analog or HDI setting, F0-13 is used as the offset value of the set value, and the offset frequency is added to the upper limit frequency value set by F0-11 as the final The setting value of upper limit frequency.

Lower limit frequency: When the frequency command is lower than the lower limit frequency, the inverter can stop, run at the lower limit frequency or run at zero speed, which operating mode can be set through F8-14 (set frequency lower than the lower limit frequency operation mode).

F0-15	carrier frequency	Factory default	Model confirmed	Attributes	○
	Predetermined area	0.5KHz ~ 16.0KHz			
F0-16	Carrier adjusts with temperature	Factory default	1	Attributes	○
	Predetermined area	0	no		
		1	yes		

When the carrier frequency is low, the high-order harmonic component of the output current increases, the motor loss increases, and the motor temperature rise increases; when the carrier frequency is high, the motor loss decreases, the motor temperature rise decreases, but the inverter loss increases, and the inverter temperature rise increases and the disturbance increases.

The adjustment of carrier frequency with temperature means that when the inverter detects that the temperature of its radiator is high, it will automatically reduce the carrier frequency to reduce the temperature rise of the inverter. When the temperature of the radiator is low, the carrier frequency gradually returns to the set value. This function can reduce the chance of inverter overheating alarm.

F0-17	Acceleration time 1	Factory default	Model confirmed	Attributes	○
	Predetermined area	0.00s ~ 6500.0s(F0-19=2) 0.0s ~ 6500.0s(F0-19=1) 0s ~ 65000s(F0-19=0)			
F0-18	Deceleration time 1	Factory default	Model confirmed	Attributes	○
	Predetermined area	0.00s ~ 6500.0s(F0-19=2) 0.0s ~ 6500.0s(F0-19=1) 0s ~ 65000s(F0-19=0)			
F0-19	Acceleration and deceleration time unit	Factory default	1	Attributes	◎
	Predetermined area	0	1 second		
		1	0.1 second		
		2	0.01 second		

Acceleration time refers to the time required for the inverter to accelerate from zero frequency to the reference frequency of acceleration and deceleration (determined by F0-21); deceleration time refers to the time required for the inverter to decelerate from the reference frequency of acceleration and deceleration (determined by F0-21) to zero frequency . As shown below:

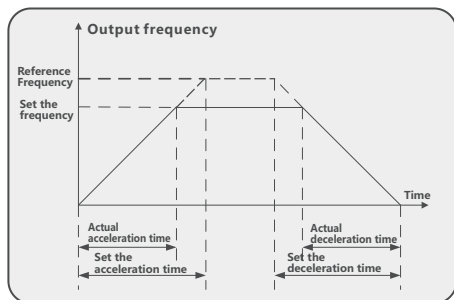

F0-20	Digital setting frequency stop memory	Factory default	0	Attributes	<input type="radio"/>
	Predetermined area	0	no memory		
		1	memory		

This function is only valid when the frequency source is set to digital. "No memory" means that after the inverter stops, the digital set frequency value returns to the value of F0-08 (preset frequency), and the frequency correction performed by the keyboard ▲, ▼ keys or terminals UP and DOWN is cleared; "Memory" It means that after the inverter stops, the digital set frequency remains as the set frequency at the last stop time, and the frequency correction made by keyboard ▲, ▼ keys or terminals UP, DOWN remains valid.

F0-21	Acceleration and deceleration time base frequency	Factory default	0	Attributes	<input type="radio"/>
	Predetermined area	0	Maximum frequency (F0-10)		
		1	set frequency		
		2	100Hz		

Acceleration and deceleration time refers to the acceleration and deceleration time from zero frequency to the frequency set by F0-21.

F0-22	Runtime UP /DOWN Benchmark	Factory default	0	Attributes	<input type="radio"/>
	Predetermined area	0	operating frequency		
		1	set frequency		

This parameter is only valid when the frequency source is digital setting. It is used to determine the way to correct the set frequency when the ▲, ▼ keys of the keyboard or the terminal UP/DOWN act, that is, whether the target frequency is increased or decreased based on the running frequency or based on the set frequency

F0-23	command source bundled frequency source	Factory default	000	Attributes	<input type="radio"/>
	Predetermined area	ones place	Operation panel binding frequency source selection		
		0	no binding		
		1	digital setting		
		2	AI1		
		3	AI2		
		4	AI3		
		5	Pulse Setting (HDI)		
		6	multi-segment command		
		7	Simple PLC		
		8	PID		
		9	Communication given		
		ten	Terminal binding frequency source selection		
		hundreds	Communication binding frequency source selection		

When the command source has a bound frequency source, the frequency source set by F0-03~F0-07 will no longer work when the command source is valid. When the command source is switched, the frequency source also switches with the bound frequency source.

F0-27	motor selection	Factory default	0	Attributes	<input type="radio"/>
	Predetermined area	0	Motor 1		
		1	motor 2		

The frequency converter supports the application of time-sharing tow two motors, and the two motors can set motor nameplate parameters, independent parameter tuning, select different control methods, and independently set parameters related to operating performance, etc.

The motor parameter 1 corresponds to the functional parameter groups F2 and F3, and the motor parameter 2 corresponds to the functional parameter A5 group.

The user selects the current motor parameter group through this parameter, and can also switch the motor parameters through the digital input terminal X. When the motor selection function is selected as the X terminal function, the setting value of this parameter will be invalid, and the X terminal selection shall prevail.

F0-28	parameter initialization	Factory default	0	Attributes	<input type="radio"/>
	Predetermined area	0	no action		
		1	Clear log information		
		2	Restore factory parameters, excluding motor parameters		
		4	Backup User Parameters		
5		restore user parameters			

#### 1. Clear record information

Clear inverter fault record information, cumulative running time, cumulative power-on time, and cumulative power consumption.

#### 2. Restore factory settings, excluding motor parameters

Most of the function parameters of the inverter are restored to the factory parameters, but the motor parameters, fault record information, accumulated running time, accumulated power-on time, and accumulated power consumption are not restored.

#### 4. Back up the user's current parameters

Backup the parameters set by the current user. Backup the setting values of all current function parameters. It is convenient for customers to recover after parameter adjustment disorder.

#### 5. Restore user backup parameters

Restore the previously backed up user parameters, that is, restore the parameters backed up by setting F0-28 to 4.

## 12.2 F1 group start and stop control

F1-00	start method	Factory default	0	Attributes	<input type="radio"/>
	Predetermined area	0	direct boot		
		1	Speed tracking restart		
		2	Pre-excitation start (AC asynchronous motor)		
3		SVC quick start			

**0: direct start**

If the starting DC braking time is set to 0, the inverter will start running from the starting frequency; if the starting DC braking time is not 0, it will start DC braking first, and then start running from the starting frequency. Applicable to small inertia loads, where the motor may rotate during startup .

**1: Speed tracking and restart**

The frequency converter first judges the speed and direction of the motor, and then starts with the frequency of the tracked motor, so as to start the rotating motor smoothly and without impact. It is suitable for restarting after momentary power failure of large inertial loads. In order to ensure the performance of speed tracking restart, it is necessary to accurately set the parameters of group F2 of the motor.

**2: Asynchronous machine pre-excitation start**

It is only valid for asynchronous motors, and is used to establish a magnetic field before the motor runs. For pre-excitation current and pre-excitation time, refer to the description of function codes F1-05 and F1-06.

If the pre-excitation time is set to 0, the inverter will cancel the pre-excitation process and start from the starting frequency; if the pre-excitation time is not 0, it will pre-excite and then start, which can improve the dynamic response performance of the motor.

**3: SVC quick start**

This method is only applicable to the SVC control mode. This method can shorten the acceleration time and is suitable for occasions where the system inertia is large and quick start is required, but there will be a current impact.

F1-01	speed tracking method	Factory default	0	Attributes	<input type="radio"/>
	Predetermined area	0	Start with stop frequency		
		1	Start from power frequency		
		2	start with maximum frequency		
F1-02	Speed tracking speed	Factory default	20	Attributes	<input type="radio"/>
	Predetermined area	1 ~ 100			

**Speed tracking method :**

**0:** Track down from the frequency at the time of power failure, usually choose this method.

**1:** It is used when the power frequency is switched to frequency conversion, and it is used in the case of restarting after a long power failure.

**2:** Track down from the maximum frequency, generally used for generating loads.

**Speed tracking speed :**

The larger the parameter, the faster the tracking speed, but setting too large may cause the tracking effect to be unreliable.

F1-03	start frequency	Factory default	0.00Hz	Attributes	<input type="radio"/>
	Predetermined area	0.00Hz ~ 50.00Hz			
F1-04	Starting frequency hold time	Factory default	0.0s	Attributes	<input type="radio"/>
	Predetermined area	0.0s ~ 100.0s			

To ensure the motor torque at startup, please set an appropriate startup frequency. In order to fully establish the magnetic flux when the motor starts, it is necessary to maintain the starting frequency for a certain period of time. The starting frequency is not limited by the lower limit frequency. But when the set target frequency is lower than the start frequency, the inverter will not start and is in standby state. During the switching process of forward and reverse rotation, the start frequency hold time does not work.

F1-05	Starting DC, pre-excitation current	Factory default	50%	Attributes	○
	Predetermined area	0%~ 100 %			
F1-06	Start DC, pre-excitation time	Factory default	0.0s	Attributes	○
	Predetermined area	0.0s~ 100.0s			
F1-07	Acceleration and deceleration mode	Factory default	0	Attributes	○
	Predetermined area	0	Linear acceleration and deceleration		
		1	static S curve		
		2	Dynamic S Curve		

Start DC braking, generally used to make the running motor stop and then start; pre-excitation is used to make the asynchronous motor build up the magnetic field before starting, and improve the response speed.

Start DC braking is only valid when the start mode is direct start. At this time, the frequency converter performs DC braking according to the set starting DC braking current, and starts running after the starting DC braking time. If the DC braking time is set to 0, it will start directly without DC braking. The greater the DC braking current, the greater the braking force.

If the start mode is asynchronous machine pre-excitation start, the inverter will first establish a magnetic field according to the set pre-excitation current, and then start running after the set pre-excitation time. If the pre-excitation time is set to 0, it will start directly without going through the pre-excitation process.

There are two situations for starting DC braking current/pre-excitation current relative to the base value.

1. When the rated current of the motor is less than or equal to 80% of the rated current of the inverter, it is the base value of the percentage relative to the rated current of the motor.

2. When the rated current of the motor is greater than 80% of the rated current of the inverter, it is the base value of the percentage relative to 80% of the rated current of the inverter.

Acceleration and deceleration mode

0: Linear acceleration and deceleration

The output frequency increases or decreases linearly.

1: Static S-curve

When the target frequency is fixed, the output frequency increases or decreases according to the S-curve. It is suitable for use in places requiring gentle start or stop, such as elevators, conveyor belts, etc.

2: Dynamic S-curve

When the target frequency changes dynamically in real time, the output frequency increases or decreases in real time according to the S-curve. It is suitable for occasions that require high comfort and fast real-time response.

F1-08	S-curve start period time ratio	Factory default	30.0%	Attributes	○
	Predetermined area	0.0%~(100.0%-F1-09)			
F1-09	S-curve end time ratio	Factory default	30.0%	Attributes	○
	Predetermined area	0.0% ~(100.0%-F1-08)			

The two function codes must meet:  $F1-08 + F1-09 \leq 100.0\%$ .



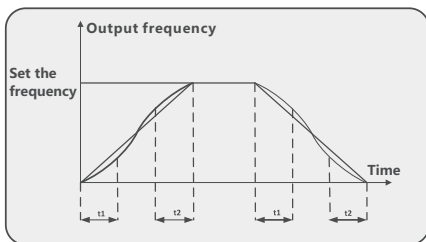

In the figure,  $t_1$  is the parameter defined by parameter F1-08, and the slope of output frequency change gradually increases during this period.  $t_2$  is the time defined by parameter F1-09, and the slope of the output frequency change gradually changes to 0 within this time period. During the time between  $t_1$  and  $t_2$ , the slope of the output frequency change is fixed, that is, linear acceleration and deceleration is performed in this interval.

F1-10	Shutdown mode	Factory default	0	Attributes	<input type="radio"/>
	Predetermined area	0	Slow down and stop		
		1	free parking		

0: After the deceleration, stop and stop command is valid, the inverter will reduce the output frequency according to the deceleration time, and stop after the frequency drops to 0.

1: After the coast to stop command is valid, the inverter stops output immediately, and the motor stops freely according to the mechanical inertia.

F1-11	Start frequency of DC braking at stop	Factory default	0.00Hz	Attributes	<input type="radio"/>
	Predetermined area	0.00Hz ~ maximum frequency			
F1-12	Stop DC braking waiting time	Factory default	0.0s	Attributes	<input type="radio"/>
	Predetermined area	0.0s ~ 100.0s			
F1-13	Stop DC brake current	Factory default	50%	Attributes	<input type="radio"/>
	Predetermined area	0% ~ 100 %			
F1-14	Stop DC braking time	Factory default	0.0s	Attributes	<input type="radio"/>
	Predetermined area	0.0s ~ 100.0s			

DC braking initial frequency at stop: During deceleration to stop, when the operating frequency drops to this frequency, the DC braking process will start.

Waiting time for DC braking at stop: After the operating frequency drops to the initial frequency of DC braking at stop, the inverter stops outputting for a period of time before starting the DC braking. It is used to prevent overcurrent and other faults that may be caused by starting DC braking at higher speeds.

DC braking current at stop: DC braking current at stop, relative to the base value, there are two situations.

1. When the rated current of the motor is less than or equal to 80% of the rated current of the inverter, it is the base value of the percentage relative to the rated current of the motor.

2. When the rated current of the motor is greater than 80% of the rated current of the inverter, it is the base value of the percentage relative to 80% of the rated current of the inverter.

DC braking time at stop: the time for maintaining the DC braking amount. If the value is 0, the DC braking process is cancelled.

F1-15	brake usage	Factory default	100%	Attributes	<input type="radio"/>
	Predetermined area	0% ~ 100%			

It is only valid for inverters with built-in braking units. It is used to adjust the duty ratio of the braking unit. If the braking utilization rate is high, the braking unit will have a high duty ratio and a strong braking effect, but the bus voltage of the inverter will fluctuate greatly during the braking process.

### 12.3 F2 group motor parameters

F2-00	motor type	Factory default	0	Attributes	<input type="radio"/>
	Predetermined area	0	Ordinary asynchronous motor		
		1	Inverter asynchronous motor		
F2-01	Motor rated power	Factory default	Model confirmed	Attributes	<input type="radio"/>
	Predetermined area	0.1kW~1000.0kW			
F2-02	Motor rated voltage	Factory default	Model confirmed	Attributes	<input type="radio"/>
	Predetermined area	1V ~ 2000V			
F2-03	Motor rated current	Factory default	Model confirmed	Attributes	<input type="radio"/>
	Predetermined area	0.01A~655.35A (inverter power≤55kW) 0.1A~6553.5A (inverter power>55kW)			
F2-04	Motor rated frequency	Factory default	Model confirmed	Attributes	<input type="radio"/>
	Predetermined area	0.01Hz ~ maximum frequency			
F2-05	Motor rated speed	Factory default	Model confirmed	Attributes	<input type="radio"/>
	Predetermined area	1rpm ~ 65535rpm			

In order to achieve a better control effect of the inverter, please set the above parameters accurately according to the nameplate of the motor.

F2-06	Asynchronous motor stator resistance	Factory default	Tuning parameters	Attributes	<input type="radio"/>
	Predetermined area	0.001Ω ~ 65.535Ω (inverter power ≤ 55kW) 0.0001Ω ~ 6.5535Ω (inverter power > 55kW)			
F2-07	Asynchronous motor rotor resistance	Factory default	Tuning parameters	Attributes	<input type="radio"/>
	Predetermined area	0.001Ω ~ 65.535Ω (inverter power ≤ 55kW) 0.0001Ω ~ 6.5535Ω (inverter power > 55kW)			
F2-08	Asynchronous motor leakage inductance	Factory default	Tuning parameters	Attributes	<input type="radio"/>
	Predetermined area	0.01mH ~ 655.35mH (inverter power ≤ 55kW) 0.001mH ~ 65.535mH (inverter power > 55kW)			

F2-09	Mutual inductance reactance of asynchronous motor	Factory default	Tuning parameters	Attributes	○
	Predetermined area	0.1mH ~ 6553.5mH (inverter power ≤ 55kW) 0.01mH ~ 655.35mH (inverter power > 55kW)			
F2-10	Asynchronous motor no-load current	Factory default	Tuning parameters	Attributes	○
	Predetermined area	0.01A~F2-03 (inverter power ≤ 55kW) 0.1A~F2-03 (inverter power > 55kW)			

The above are the tuning parameters of the asynchronous motor. These parameters are generally not listed on the motor nameplate and need to be obtained through automatic tuning of the frequency converter. Among them, "Asynchronous Motor Static Part Parameter Tuning" can only obtain the three parameters F2-06 ~ F2-08, while "Asynchronous Motor Dynamic Complete Tuning" and "Asynchronous Motor Static Complete Tuning" can obtain all the above parameters.

When changing the rated power of the motor or the rated voltage of the motor, the frequency converter will automatically modify the above parameter values and restore these parameters to the default parameters of common standard motors.

F2-37	tuning selection	Factory default	0	Attributes	○	
	Predetermined area	0	no action			
		1	Parameter Tuning of Static Part of Asynchronous Machine			
		2	Dynamic complete tuning of asynchronous machines			
3	Asynchronous machine static complete tuning					

F2-00~F2-05 must be correctly set before parameter self-learning, and the encoder type(Fd-01) and pulse number (Fd-00) must be additionally set during closed-loop vector control.

Tuning action description: Set the motor nameplate parameters and self-learning type, then press the RUN key, the inverter will tune.

0 : no operation:

That is, tuning is disabled.

1 : Parameter tuning of the static part of the asynchronous machine

It is suitable for the occasions where the synchronous motor and the large inertia load are not easy to disengage and the rotation tuning cannot be performed.

2 : Dynamic and complete tuning of the asynchronous machine

In the process of dynamic tuning, the inverter performs static tuning first, then accelerates to 80% of the motor's rated frequency according to the acceleration time, and after a period of time, decelerates to stop according to the deceleration time and ends the tuning.

3 : The asynchronous machine is static and complete tuning

Applicable to the situation without an encoder, self-learning of motor parameters when the motor is at rest (the motor may still vibrate slightly at this time, please pay attention to safety)

### 12.4 F3 group vector control parameters

F3-00	Speed/torque control selection	Factory default	0	Attributes	○
	Predetermined area	0	speed control		
		1	torque control		

Speed control/torque control switching ( X x function selection 46). These two terminals should be used in conjunction with F3-00 to realize switching between speed and torque control.

When the speed control/torque control switching terminal is invalid, it is the control mode selected by F3-00 ; if the speed control/torque control switching terminal is valid, it is the control mode not selected by F3-00 .

When the torque control prohibition terminal ( X x function selection 29) is valid, the inverter is fixed in the speed control mode

F3-01	Speed loop proportional gain 1	Factory default	30	Attributes	○
	Predetermined area	1 ~ 100			
F3-02	Speed loop integration time 1	Factory default	0.50s	Attributes	○
	Predetermined area	0.01s ~ 10.00s			
F3-03	Switching frequency 1	Factory default	5.00Hz	Attributes	○
	Predetermined area	0.00Hz ~ F3-06			
F3-04	Speed loop proportional gain 2	Factory default	20	Attributes	○
	Predetermined area	1 ~ 100			
F3-05	Speed loop integration time 2	Factory default	1.00s	Attributes	○
	Predetermined area	0.01s ~ 10.00s			
F3-06	Switching frequency 2	Factory default	10.00Hz	Attributes	○
	Predetermined area	F3-03 ~ maximum frequency			

By setting the proportional gain and integral time of the speed loop, the speed dynamic response characteristics of the vector control can be adjusted. Increasing the proportional gain and reducing the integral time can speed up the dynamic response of the speed loop. However, if the proportional gain is too large or the integral time is too small, the system may oscillate.

In the vector control mode, the corresponding speed loop PI parameters can be selected according to the operating frequency. When the running frequency is less than or equal to switching frequency 1, the speed loop selects the first set of PI parameters (proportional gain 1, integral time 1); when the running frequency is greater than or equal to switching frequency 2, the speed loop selects the second set of PI parameters (proportional gain 2, integral time 2); when the operating frequency is between switching frequency 1 and switching frequency 2, the parameter is the result of linear conversion of two sets of parameters , as shown in the figure below:

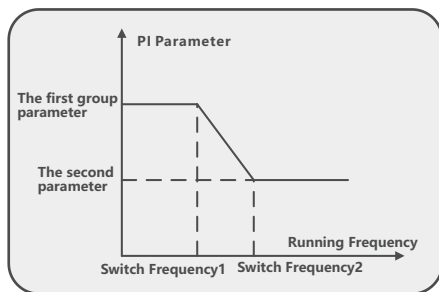

F3-07	Vector control slip gain	Factory default	100%	Attributes	<input type="radio"/>
	Predetermined area	50% ~ 200%			

In the vector control mode without speed sensor , this parameter is used to adjust the steady-state accuracy of the motor: when the speed of the motor is low, increase this parameter, otherwise decrease; in the vector control mode with speed sensor , this parameter can be adjusted under the same load The output current of the inverter.

F3-08	SVC speed feedback filter time	Factory default	0.050s	Attributes	<input type="radio"/>
	Predetermined area	0.000s ~ 1.000s			

This parameter is only valid in SVC control mode. Setting a large parameter can improve the stability of the motor, but the dynamic response is slow; reducing the parameter, the dynamic response is fast, but it may cause the motor to oscillate.

F3-10	Speed control torque upper limit source	Factory default	0	Attributes	<input checked="" type="radio"/>	
	Predetermined area	0	F3-11 setting			
		1	AI1			
		2	AI2			
		3	AI3			
		4	HDI pulse			
		5	communication settings			
		6	MIN (AI1,AI2)			
7	MAX (AI1,AI2)					
F3-11	Torque upper limit digital setting	Factory default	150.0%	Attributes	<input type="radio"/>	
	Predetermined area	0.0% ~ 200.0%				
F3-12	Speed control torque upper limit source (power generation )	Factory default	0	Attributes	<input checked="" type="radio"/>	
	Predetermined area	0	F3-10 setting (no distinction between electric and power generation )			
		1	AI1			
		2	AI2			
		3	AI3			
		4	HDI pulse			
		5	communication settings			
		6	M IN (AI1,AI2)			
		7	MAX (AI1,AI2)			
8	Parameter F3-13 setting					
F3-13	Torque upper limit digital setting(power generation )	Factory default	150.0%	Attributes	<input type="radio"/>	
	Predetermined area	0.0% ~ 200.0%				

The above parameters are used to set the output torque upper limit value in vector control speed mode. Torque upper limit can be set through digital setting, AI x analog quantity, HDI pulse and communication. When setting through AI analog quantity, HDI pulse and communication, 100% corresponds to F3-11, and 100% of F3-11 % corresponds to the rated output current of the inverter.

Example: when F3-10=1, the torque upper limit source is AI1 ; F3-11 = 150.0% , when AI1 input 50% , the set torque upper limit at this time is 50% X 150.0% =75.0% rated current.

Torque limit is divided into motoring state and generating state. In the electric state, the torque upper limit is determined by F3-10 and F3-11 ; in the power generation state, the torque upper limit is determined by F3-12 and F3-13 . If F3-12 is set to 0, no motor generator is distinguished, and the torque upper limit is determined by F3-10 and F3-11 .

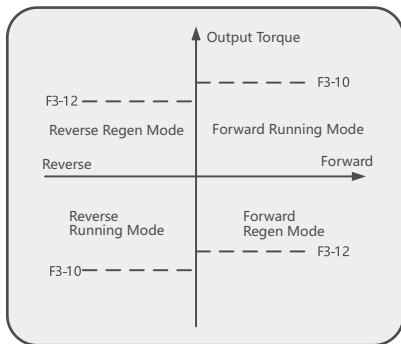

F3-14	Excitation regulation proportional gain	Factory default	2000	Attributes	○
	Predetermined area	0 ~ 60000			
F3-15	Excitation regulation integral gain	Factory default	1300	Attributes	○
	Predetermined area	0 ~ 60000			
F3-16	Torque regulation proportional gain	Factory default	2000	Attributes	○
	Predetermined area	0 ~ 60000			
F3-17	Torque adjustment integral gain	Factory default	1300	Attributes	○
	Predetermined area	0 ~ 60000			

Vector control current loop PI adjustment parameters, the above parameters will be obtained automatically after the asynchronous machine is tuned, and generally do not need to be modified. Note: The integral regulator of the current loop does not use the integral time as the dimension, but directly sets the integral gain.

If the current loop PI gain is set too large, it may cause the entire control loop to oscillate. Therefore, when the current oscillates or the torque fluctuates greatly, you can manually reduce the PI proportional gain or integral gain here.

F3-23	Generation power limit enable	Factory default	0	Attributes	
	Predetermined area	0	invalid		
1		efficient			
F3-24	Generating power upper limit	Factory default	Model confirmed	Attributes	○
	Predetermined area	0.0% ~ 200.0%			

In the vector control speed mode, the power limit function can effectively reduce the overshoot of the bus voltage during the motor braking process and avoid the occurrence of overvoltage faults. The upper limit of generating power F3-24 is the percentage of the rated power of the motor. When overvoltage still occurs after enabling the generating power limit function, please adjust F3-24 downward.

The above part of the parameters in Group F3 are the related parameters of the vector speed mode, and the following are the related parameters of the vector torque mode.

F3-25	Torque control torque upper limit source	Factory default	0	Attributes	○	
	Predetermined area	0	Digital setting (F3-27)			
		1	AI1			
		2	AI2			
		3	AI3			
		4	HDI			
		5	communication settings			
		6	MIN (AI1,AI2)			
7	MAX (AI1,AI2)					
F3-27	Torque control torque upper limit	Factory default	150.0%	Attributes	○	
	Predetermined area	-200.0% ~ 200.0 %				

The torque setting adopts relative value, 100.0% corresponds to the rated torque of the motor. The setting range is -200.0%~200.0%, indicating that the maximum torque of the inverter is twice the rated torque of the inverter. When the given torque is positive, the inverter runs forward; when the given torque is negative, the inverter runs in reverse.

F3-29	Torque control forward maximum frequency	Factory default	50.00Hz	Attributes	○
	Predetermined area	0.00 ~ maximum frequency			
F3-30	Torque control reverse maximum frequency	Factory default	50.00Hz	Attributes	○
	Predetermined area	0.00 ~ maximum frequency			

When the inverter torque control, if the load torque is less than the motor output torque, the motor speed will continue to rise, in order to prevent accidents such as speeding of the mechanical system, the maximum speed of the motor must be limited during torque control. During torque control, the acceleration and deceleration time of frequency upper limit is set in F8-07 (acceleration time 4)/F8-08 (deceleration time 4) default to 0.0s. It is used to set the forward or reverse maximum operating frequency of the inverter in the torque control mode. If the maximum frequency of torque control needs to be changed dynamically and continuously, it can be realized by controlling the upper limit frequency.

F3-31	Torque rise filter time	Factory default	0.00s	Attributes	<input type="radio"/>
	Predetermined area	0.00s ~ 650.00s			
F3-32	Torque drop filter time	Factory default	0.00s	Attributes	<input type="radio"/>
	Predetermined area	0.00s ~ 650.00s			

In the torque control mode, the difference between the motor output torque and the load torque determines the speed change rate of the motor and the load. Therefore, the motor speed may change rapidly, causing problems such as noise or excessive mechanical stress. By setting the torque control acceleration and deceleration time, the motor speed can be changed smoothly.

For example: two motors are hard-connected to drive the same load. In order to ensure uniform load distribution, set one inverter as the master and adopt speed control mode, and the other inverter as slave and adopt torque control. The actual output speed of the master The torque is used as the torque command of the slave machine. At this time, the torque of the slave machine needs to quickly follow the master machine, so the acceleration and deceleration time of the torque control of the slave machine is 0.00s.

### 12.5 F4 group V/F control parameters

F4-00	V/F curve setting	Factory default	0	Attributes	<input type="radio"/>	
	Predetermined area	0	Straight line V/F			
		1	Multi-point V/F			
		2~9	reserve			
		10	V/F complete separation mode			
		11	V/F semi-separated mode			

0: Straight line V/F

Suitable for ordinary constant torque loads.

1: Multi-point V/F

Suitable for special loads such as dehydrators and centrifuges. At this time, any V/F relationship curve can be obtained by setting the parameters of F4-03 ~ F4-08.

10: V/F complete separation mode

At this time, the output frequency and output voltage of the inverter are independent of each other, the output frequency is determined by the frequency source, and the output voltage is determined by F4-13 (V/F separation voltage source). V/F complete separation mode, generally used in induction heating, inverter power supply, torque motor control and other occasions.

11: V/F semi-separated mode

In this case, Vand Fare proportional, but the proportional relationship can be set through the voltage source F4-13, and the relationship between Vand Fis also related to the rated voltage and rated frequency of the motor in Group F2. Assuming that the voltage source input is X (X is a value of 0~100%), the relationship between the output voltage V of the inverter and the frequency Fis:  $V/F=2 * X * (\text{motor rated voltage}) / (\text{motor rated frequency})$

F4-01	torque boost	Factory default	Model confirmed	Attributes	<input type="radio"/>
	Predetermined area	0.0% ( automatic torque boost ) 0.1 % ~ 30.0%			
F4-02	Torque boost cut-off frequency	Factory default	50.00Hz	Attributes	<input type="radio"/>
	Predetermined area	0.00Hz ~ maximum frequency			



Torque boost is used to compensate the low-frequency torque characteristics of V/F control. If the torque boost is set too large, it will easily lead to overcurrent or overload faults, and the motor will easily overheat ; if the torque boost is set too small, it will easily cause the motor to stall. Adjust torque boost parameters for actual load conditions.

When the torque boost is set to 0.0%, the inverter will automatically calculate the required torque boost value according to the motor stator resistance and other parameters. At this time, if conditions permit, please perform parameter tuning on the motor to obtain accurate motor parameters.

Torque boost Torque cut-off frequency: Below this frequency, the torque boost amount is linearly calculated according to the operating frequency and the cut-off frequency . If the frequency exceeds this setting, the torque boost will not work . See the figure below for details :

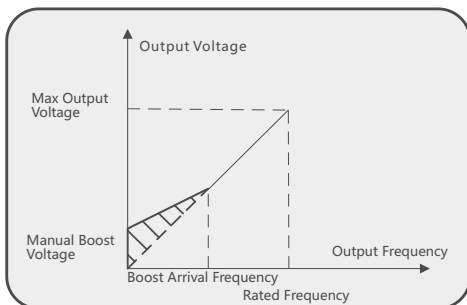

F4-03	Multi-point V/F frequency point F1	Factory default	0.00Hz	Attributes	⊙
	Predetermined area	0.00Hz ~ F4.05			
F4-04	Multi-point V/F voltage point V1	Factory default	0.0%	Attributes	⊙
	Predetermined area	0.0% ~ 100.0%			
F4-05	Multi-point V/F frequency point F2	Factory default	0.00Hz	Attributes	⊙
	Predetermined area	F4-03 ~ F4-07			
F4-06	Multi-point V/F voltage point V2	Factory default	0.0%	Attributes	⊙
	Predetermined area	0.0% ~ 100.0%			
F4-07	Multi-point V/F frequency point F3	Factory default	0.00Hz	Attributes	⊙
	Predetermined area	F4-05 ~ motor rated frequency			
F4-08	Multi-point V/F voltage point V3	Factory default	0.0%	Attributes	⊙
	Predetermined area	0.0% ~ 100.0%			

The multi-point V/F curve should be set according to the load characteristics of the motor. It should be noted that the relationship between the three voltage points and frequency points must satisfy:  $V1 < V2 < V3$ ,  $F1 < F2 < F3$ . If the voltage is set too high at low frequency, it may cause the motor to overheat or even burn out, and the frequency converter may suffer from overcurrent stall or overcurrent protection.

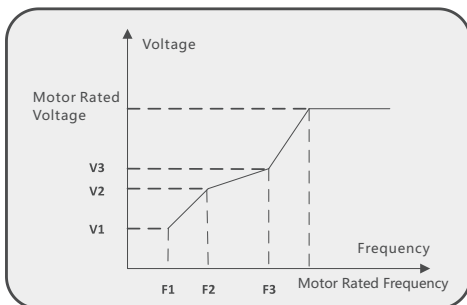

F4-09	V/F slip compensation gain	Factory default	0.0%	Attributes	<input type="radio"/>
	Predetermined area	0% ~ 200.0%			

V/F slip compensation can compensate the motor speed deviation of the asynchronous motor when the load increases, so that the motor speed can basically remain stable when the load changes.

The V/F slip compensation gain is set to 100.0%, which means that when the motor is under rated load, the compensated slip is the rated slip of the motor, and the rated slip of the motor is automatically calculated according to the rated frequency and rated speed of the motor.

When adjusting the V/F slip compensation gain, it is generally based on the principle that the motor speed is basically the same as the target speed under the rated load. When the motor speed is different from the target value, the gain needs to be fine-tuned appropriately.

F4-10	V/F overexcitation gain	Factory default	64	Attributes	<input type="radio"/>
	Predetermined area	0 ~ 200			

During the deceleration process of the inverter, the over-excitation control can suppress the rise of the bus voltage and avoid overvoltage faults. The larger the overexcitation gain, the stronger the suppression effect.

For occasions where the inverter is prone to overvoltage alarm during deceleration, it is necessary to increase the overexcitation gain. However, if the overexcitation gain is too large, it is easy to cause the output current to increase and the motor to heat up.

For occasions with small inertia and no voltage rise during motor deceleration, it is recommended to set the overexcitation gain to 0; for occasions with braking resistors, it is also recommended to set the overexcitation gain to 0.

F4-11	V/F oscillation suppression gain	Factory default	40	Attributes	<input type="radio"/>
	Predetermined area	0 ~ 100			

In the V/F control mode, if the motor vibrates obviously, the gain can be increased appropriately, the greater the gain, the more obvious the suppression of the oscillation. Set it as small as possible under the premise of effectively suppressing oscillation, so as not to have adverse effects on V/F operation. Please select this gain as 0 when the motor has no oscillation phenomenon.

When using the oscillation suppression function, the motor rated current and no-load current parameters are required to be accurate, otherwise the V/F oscillation suppression effect is not good.

F4-13	V/F separated voltage source	Factory default	0	Attributes	○	
	Predetermined area	0	Digital setting (F4-14 )			
		1	AI1			
		2	AI2			
		3	AI3			
		4	Pulse setting HDI			
		5	multi-segment command			
		6	Simple PLC			
		7	PID			
8	communication settings					
F4-14	Voltage digital setting with V/F separation	Factory default	0V	Attributes	○	
	Predetermined area	0V ~ motor rated voltage				

V/F separation is generally used in induction heating, inverter power supply and torque motor control and other occasions.

When V/F separation control is selected, the output voltage can be set through function code F4-14, or it can come from analog quantity, pulse setting HDI, multi-segment instruction, simple PLC, PID or communication setting. When non-digital settings are used, 100% of each setting corresponds to the rated voltage of the motor. When the percentage of output settings such as analog quantities is a negative number, the absolute value of the setting is taken as the effective setting value.

0: digital setting

The voltage is directly set by F4-14.

1: AI1

2: AI2

3: AI3

The voltage is determined by the analog input terminals.

4. Pulse setting HDI

Voltage setting is given by terminal pulse. Pulse given signal specifications: voltage range 9V ~ 30V, frequency range 0kHz ~ 100kHz.

5. Multi-segment instructions

When the voltage source is a multi-segment command, set the FA group parameters to determine the given voltage. The 100.0% of the multi-stage command setting of the FA group parameters refers to the percentage relative to the rated voltage of the motor.

6. Simple PLC

When the voltage source is a simple PLC, it is necessary to set the FA group parameters to determine the given output voltage.

7. PID

The output voltage is generated according to the PID closed loop. For details, refer to the introduction of F9 group PID.

8. Communication setting

Refers to the voltage is given by the host computer through communication.

V/F separation voltage source selection is similar to frequency source selection, see F0-03 main frequency source selection introduction. Among them, 100.0% of the corresponding settings for various options refers to the rated voltage of the motor (take the absolute value of the corresponding setting value).

F4-15	V/F separation	Factory default	0.0s	Attributes	○
	Predetermined area	0.0s ~ 1000.0s			

F4-16	V/F separation	Factory default	0.0s	Attributes	<input type="radio"/>
	Predetermined area	0.0s ~ 1000.0s			

Like the frequency acceleration and deceleration time, the voltage rise (fall) time refers to the time required for acceleration (deceleration) from 0 voltage (motor rated voltage) to the motor rated voltage (0 voltage), not from 0 voltage (target voltage), the time to accelerate (decelerate) to the target voltage (0 voltage).

F4-17	V/F separation stop mode selection	Factory default	0	Attributes	<input type="radio"/>
	Predetermined area	0	0: frequency/voltage independently reduced to 0		
		1	1: After the voltage is reduced to 0, the frequency will be reduced again		

0: frequency/voltage independently reduced to 0

When the inverter stops, the frequency and voltage will decrease according to their respective acceleration and deceleration time.

1: After the voltage is reduced to 0, the frequency will be reduced again

V according to the voltage drop time, the frequency decreases to 0 Hz according to the deceleration time

F4-18	Overrun stall action current	Factory default	150%	Attributes	<input checked="" type="radio"/>
	Predetermined area	50% ~ 200.0%			
F4-19	Overrun stall enable	Factory default	1	Attributes	<input checked="" type="radio"/>
	Predetermined area	0	invalid		
		1	efficient		
F4-20	Overflow stall suppression gain	Factory default	20	Attributes	<input type="radio"/>
	Predetermined area	0 ~ 100			
F4-21	Double speed flow stall action current compensation coefficient	Factory default	50%	Attributes	<input checked="" type="radio"/>
	Predetermined area	50% ~ 200%			

Overrun stall enable :

Overrun stall action current :

Enable the function of overcurrent stall, when the output current of the inverter reaches the action current of overflow stall, the output frequency of the inverter will start to adjust the output frequency, if it is in the motoring state at this time, the output frequency will start to decrease and adjust; if it is in the power generation state at this time, Then the output frequency starts to rise and adjust. At this time, the acceleration and deceleration time will be automatically lengthened. If the actual acceleration and deceleration time cannot meet the requirements, the overcurrent stall action current can be increased appropriately.

Overflow stall suppression gain:

When an overcurrent stall occurs, the inverter adjusts the output frequency to PI regulation, and both the P proportional gain and the I integral time are uniformly adjusted by the overflow stall restrain parameter.

Double-speed overflow stall action current compensation coefficient:

In the high-frequency region, the motor drive current is small. Compared with below the rated frequency, the speed of the motor drops greatly for the same stall current. In order to improve the operating characteristics of the motor, the stall action current above the rated frequency can be reduced. In some centrifuges This method has a good effect on the acceleration performance when the operating frequency is

high, several times of magnetic field weakening is required and the load inertia is large. Overcurrent stall action current exceeding the rated frequency =  $(f_s/f_n) * k * \text{LimitCur}$ ;  $f_s$  is the running frequency,  $f_n$  is the rated frequency of the motor,  $k$  is F4-21 "multiple speed overflow stall action current compensation coefficient", and  $\text{LimitCur}$  is F4-18 "overflow stall action current".

When F4-21 is set to 5 0%, it means that the compensation coefficient of the double-speed overrun stall action does not work.

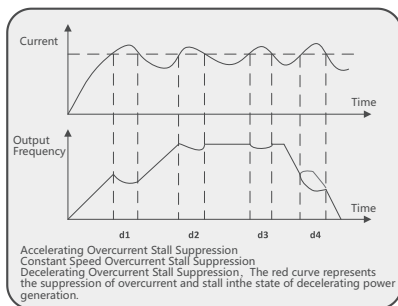

F4-22	Overvoltage stall action voltage	Factory default	Model confirmed	Attributes	<input type="radio"/>
	Predetermined area	380V model: 650.0V~800.0V; 220V model: 320.0V~800.0V			
F4-23	Overvoltage stall enable	Factory default	1	Attributes	<input type="radio"/>
	Predetermined area	0	invalid		
		1	efficient		
F4-24	Overvoltage stall suppression frequency gain	Factory default	30	Attributes	<input type="radio"/>
	Predetermined area	0 ~ 100			
F4-25	Overvoltage stall suppress voltage gain	Factory default	30	Attributes	<input type="radio"/>
	Predetermined area	0 ~ 100			
F4-26	Overvoltage stall maximum rising frequency	Factory default	5Hz	Attributes	<input type="radio"/>
	Predetermined area	0 ~ 50Hz			

When the bus voltage reaches the set value of the overvoltage stall action voltage, the actual speed of the motor is greater than the motor speed corresponding to the output frequency of the inverter, and the motor is in the power generation state. In order to protect the safety of the system and avoid trip protection, the inverter starts the overvoltage stall Protection function, increasing the output frequency, the actual deceleration time will be automatically lengthened, if the actual deceleration time cannot meet the system requirements, you can properly increase the overexcitation gain or install a braking resistor.

When the overvoltage stall action occurs, the frequency converter adjusts the output frequency and output voltage through PI control at the same time. The overvoltage stall suppression frequency gain is used to modify the proportional gain and integral time of frequency adjustment PI; the overvoltage stall suppression voltage gain is used to modify the voltage Adjust the proportional gain and integral time of PI.

The maximum rising frequency of overvoltage stall is used to limit the maximum rising frequency during frequency regulation.

Note: The bus voltage limit function in the vector control mode also needs to enable the F4-23 overvoltage stall enable function, and set the F4-22 limit voltage point.

## 12.6 F5 group of input terminals

NVF3 series inverters are equipped with 5 multi-functional digital input terminals (HDI can be used as high-speed pulse input terminals) and 2 analog input terminals as standard. The following functions can be set for each input terminal.

Set value	Function	Illustrate
0	no function	Unused terminals can be set as "no function" to prevent malfunction.
1	Forward running FWD	Control the forward and reverse rotation of the inverter through external terminals.
2	run REV in reverse	
3	Three-wire operation control	It is used for running control in the control terminal mode, refer to the description of function code F5-11 ("terminal command mode").
4	forward jog	It is used for jog running control in the control terminal mode, and the jog running frequency and acceleration/deceleration time are defined in F8-00 ~ F8-02.
5	reverse jog	
6	Terminal UP	When the frequency source is set to digital setting, when modifying the frequency, it is used as an increment and decrement instruction.
7	Terminal DOWN	
8	free parking	Use the control terminal to realize free running stop, which is the same as the function defined in F1-10.
9	fault reset	Use the terminal to perform fault reset function. It has the same fault reset function as the STOP key on the button, and this function can realize remote fault reset.
10	run pause	The inverter decelerates to stop, and when the terminal is valid, all operating parameters are memorized (such as PLC parameters, PID parameters); when the terminal is invalid, the inverter resumes the previously memorized running state.
11	External fault normally open input	The fault signal of the external equipment can be input through this terminal, which is convenient for the inverter to monitor the fault of the external equipment. After the inverter receives the external equipment failure signal, it will display "E.EF", that is, the external equipment failure alarm.
12	Multi-stage command terminal 1	16- stage speed setting can be realized through 16 states of these four terminals.
13	Multi-stage instruction terminal 2	
14	Multi-stage instruction terminal 3	
15	Multi-stage command terminal 4	
16	Acceleration and deceleration time selection terminal 1	4 states of this terminal, the selection of 4 acceleration and deceleration times can be realized.
17	Acceleration and deceleration time selection terminal 2	

18	Frequency command switching	It is used to switch and select different frequency sources. For details, please refer to the description of function code F0-07. When switching between two frequency sources is set as the target frequency, frequency source switching can be realized through this terminal.
19	UP/DOWN setting reset (terminal, keyboard)	When the main frequency is set by digital reference, terminal selection of this function can clear the frequency value changed by the keyboard up and down keys or multifunction terminal 6(UP) and 7(DOWN), and restore the given frequency to the setting of F0-08
20	Control command switching terminal 1	Through this terminal, the control command source can be switched from terminal control or communication control to panel control.
21	Acceleration and deceleration prohibited	Maintain the current output frequency (except stop command).
22	PID pause	The inverter maintains the current output frequency and suspends PID regulation .
23	Simple PLC status reset	Restore the inverter to the initial state of the simple PLC.
24	counter input	input Input terminal for count pulses.
25	counter reset	Clear the counter status.
26	Length count input	Input terminal for length counting.
27	length reset	The length is cleared to zero.
28	Torque control prohibited	The inverter prohibits the torque control mode and automatically enters the speed control mode.
29	Pulse frequency input (valid for HDI only)	Set HDI to be used as a high-speed pulse input terminal.
30	reserve	reserve.
31	Immediate DC braking	The frequency converter switches directly to the DC braking state.
32	External fault normally closed input	The fault signal of the external equipment can be input through this terminal, which is convenient for the inverter to monitor the fault of the external equipment. After the inverter receives the external equipment failure signal, it will display " E.EF ", that is, the external equipment failure alarm.
33	Frequency modification enable	This terminal can be used to control whether the change and modification of the inverter frequency is valid. When the state of this terminal is valid, the frequency of the inverter can be modified; otherwise, the frequency will not change.When this function is not set, the setting of the main frequency and the auxiliary frequency is not affected.
34	The direction of PID action is reversed	When this terminal is valid, the PID function is opposite to the setting of F9-03 .
35	External parking terminal 1	Control the inverter to stop normally, only valid under panel control.
36	Control command switching terminal 2	Used to switch between terminal control and communication control.
37	PID integration pause	The integral adjustment function of PID is suspended, and the proportional adjustment and differential adjustment are still valid at this time.The integral attribute of PID is required to be F9-25=x1

38	Main frequency and preset frequency switching	When this terminal is valid, the frequency source X is replaced by the preset frequency (F0-08).
39	Auxiliary frequency and preset frequency switching	When this terminal is valid, the frequency source Y is replaced by the preset frequency (F0-08).
40	Motor selection terminal	Select motor 1 when the terminal is invalid, and select motor 2 when the terminal is valid.
41	reserve	reserve.
42	PID parameter switching	When F9-18=1 (PID parameter is switched through X terminal), when the terminal state is 0, the PID parameter uses F9-05~F9-07; when the terminal state is 1, the PID parameter uses F9-15~F9-17.
43	User-Defined Fault 1	When the user-defined fault terminals 1 and 2 are valid, the inverter will alarm E.US1 and E.US2 respectively, and the inverter will handle the fault according to the parameters selected by FE-49.
44	User-Defined Fault 2	
45	Speed control/torque control switching	Used to switch between speed control mode and torque control mode.
46	emergency pull over	The inverter is in the fastest deceleration state, at this time the deceleration current and voltage are in the maximum limit state.
47	External Parking Terminal 2	When the state of this terminal is valid, the inverter enters the deceleration stop state, and the deceleration time adopts deceleration time 4. Valid in all control modes.
48	Deceleration DC braking	The inverter decelerates to the initial frequency of DC braking and enters the DC braking deceleration state.
49	This run time is cleared	Clear the running time of the inverter this time, which is used for timing running function (F8-42).
50	Two-wire / three-wire switching	Used to switch between two-wire and three-wire control methods. (two-wire1 switches to three-wire1, two-wire2 switches to three-wire2.)
51	Reverse Frequency Prohibited	The reverse frequency is prohibited, and the inverter runs at 0Hz when it reverses.

The 4 multi-segment command terminals can set a maximum of 16-segment operating frequency, which can be selected through the arrangement and combination of 4 X terminals. It is also possible to perform multi-segment frequency setting with fewer than 4 X terminals. For the missing setting bits, they are calculated as 0, as shown in the following table:



K4	K3	K2	K1	Command setting		Corresponding parameter
0	0	0	0	Multi-band	frequency 0	FA-00
0	0	0	1	Multi-band	frequency 1	FA-01
0	0	1	0	Multi-band	frequency 2	FA-02
0	0	1	1	Multi-band	frequency 3	FA-03
0	1	0	0	Multi-band	frequency 4	FA-04
0	1	0	1	Multi-band	frequency 5	FA-05
0	1	1	0	Multi-band	frequency 6	FA-06
0	1	1	1	Multi-band	frequency 7	FA-07
1	0	0	0	Multi-band	frequency 8	FA-08
1	0	0	1	Multi-band	frequency 9	FA-09
1	0	1	0	Multi-band	frequency 10	FA-10
1	0	1	1	Multi-band	frequency 11	FA-11
1	1	0	0	Multi-band	frequency 12	FA-12
1	1	0	1	Multi-band	frequency 13	FA-13
1	1	1	0	Multi-band	frequency 14	FA-14
1	1	1	1	Multi-band	frequency 15	FA-15

The dimension of the multi-segment instruction is a relative value, which is a percentage of the relative maximum frequency F0-10 . The positive or negative of the parameter determines the running direction, if it is negative, it means the inverter runs in the opposite direction.

The function description of the acceleration and deceleration time selection terminal is shown in the following table:

Terminal 1	Terminal 2	Acceleration\deceleration time	Corresponding parameter
0	0	Acceleration\deceleration time 1	F0-17\F0-18
0	1	Acceleration\deceleration time 2	F8-03\F8-04
1	0	Acceleration\deceleration time 3	F8-05\F8-06
1	1	Acceleration\deceleration time 4	F8-07\F8-08

F5-10	X terminal filter time	Factory default	0.010s	Attributes	<input type="radio"/>
	Predetermined area	0.000s ~ 1.000s			

It is used to set the filter time of the X terminal . Decreasing this parameter can speed up the response time of the X terminal , but its anti-interference ability will be reduced; increasing this parameter can enhance the anti-interference ability, but it will cause the response of the X terminal to slow down.

F5-11	Terminal command mode	Factory default	0	Attributes	<input type="radio"/>	
	Predetermined area	0	Two-wire 1			
		1	Two-wire 2			
		2	Three-wire type 1			
		3	Three-wire 2			

X1 ~ X4 and HDI input terminals can be selected arbitrarily as external input terminals, that is, by setting F5.00 ~ F5.04 value to select the function of X1 ~ X4 , HDI input terminal.

0: Two-wire control mode 1 :

As shown in the figure below, when K1 is closed alone, the inverter runs forward; when K2 is closed alone, the inverter runs reversely; when K1 and K2 are closed or disconnected at the same time, the inverter stops running

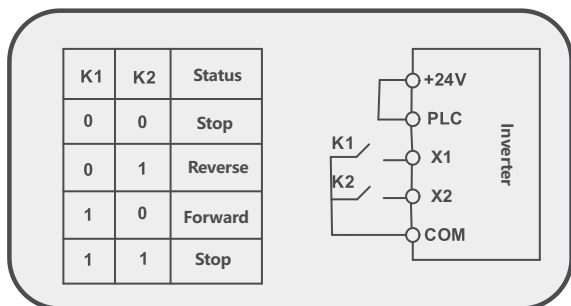

The function code is set as follows:

Function code	Name	Set value	Parameter Description
F0-02	run command channel selection	1	terminal control
F5-11	Terminal control mode selection	0	Two-wire 1
F5-00	X1 terminal function selection	1	Forward rotation ( FWD )
F5-01	X2 terminal function selection	2	reverse ( REV )

1: Two-wire control mode 2 :

In this mode, the X1 terminal is the running enable terminal, and the function of the X2 terminal is to determine the running direction. As shown in the figure below, in this mode , when K1 is closed, K2 is disconnected, and the inverter rotates forward, and K2 is closed, and the inverter rotates reversely; when K1 is disconnected, the inverter stops running.

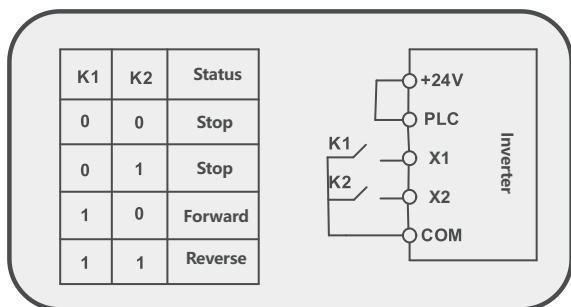

The function code is set as follows:

Function code	Name	Set value	Parameter Description
F0-02	run command channel selection	1	terminal control
F5-11	Terminal control mode selection	1	Two-wire 2
F5-00	X1 terminal function selection	1	Forward (acts as "run enable")
F5-01	X2 terminal function selection	2	Reverse (acts as "forward and reverse running direction")

**2: Three-wire control mode 1 :**

In this mode, the X3 terminal is the running enable terminal, and the direction is controlled by X1 and X2 respectively . As shown in the figure below, in this control mode , when the SB1 button is closed, press the SB2 inverter to rotate forward, press the SB3 button to reverse the inverter, and the SB1 button is disconnected to stop the inverter immediately.

the SB1 button must be kept in the closed state, and the commands of the SB2 and SB3 buttons will take effect at the edge of the closing action.

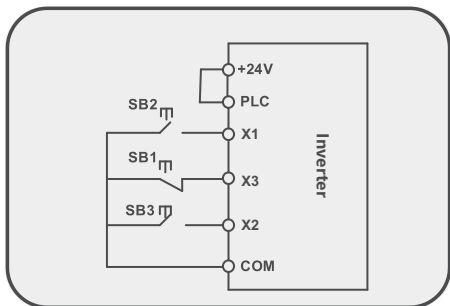

Function code	Name	Set value	Parameter Description
F0-02	run command channel selection	1	terminal control
F5-11	Terminal control mode selection	2	Three-wire type 1
F5-00	X1 terminal function selection	1	Forward rotation( FWD )
F5-01	X2 terminal function selection	2	reverse ( REV )
F5-02	X3 terminal function selection	3	Three-wire operation control

**3: Three-wire control mode 2 :**

In this mode, the X3 terminal is the running enable terminal, the running command is given by X1 , and the direction is determined by the state of X2 . As shown in the figure below, in this control mode , when the SB1 button is closed, the inverter runs when the SB2 button is pressed , the inverter runs forward when K is off, and the inverter reverses when K is closed; the inverter stops immediately when the SB1 button is off. During normal startup and operation, the SB1 button must be kept in the closed state, and the command of the SB2 button will take effect at the edge of the closing action.

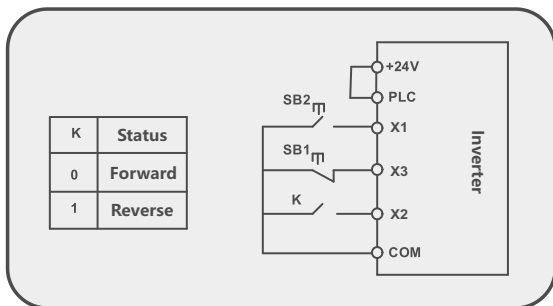

The function code is set as follows:

Function code	Name	Set value	Parameter Description
F0-02	run command channel selection	1	terminal control
F5-11	Terminal control mode selection	3	Three-wire 2
F5-00	DI1 terminal function selection	1	Forward (acts as "run enable")
F5-01	DI2 terminal function selection	2	Reverse (acts as "forward and reverse running direction ")
F5-02	DI3 terminal function selection	3	Three-wire operation control

F5-12	Terminal UP/DOWN change rate	Factory default	1.00Hz/s	Attributes	○
	Predetermined area	0.001Hz/s~65.535Hz/s			

using UP \ DOWN to modify the target frequency, the frequency change speed, that is, the amount of change per second.

F5-13	AI curve 1 minimum input	Factory default	0.00V	Attributes	○
	Predetermined area	0.00V~F5-15			
F5-14	AI curve 1 minimum input corresponding setting	Factory default	0.00%	Attributes	○
	Predetermined area	-100.0%~+100.0%			
F5-15	AI curve 1 maximum input	Factory default	10.00V	Attributes	○
	Predetermined area	F5-13~+10.00V			
F5-16	AI curve 1 maximum input corresponding setting	Factory default	100.00%	Attributes	○
	Predetermined area	-100.0%~+15 0.0%			
F5-17	AI1 filter time	Factory default	0.10s	Attributes	○
	Predetermined area	0.00s~10.00s			

The setting of AI curve is actually to set the relationship between the analog input voltage (or analog input current) and the set frequency it represents. When AI is used as frequency setting, 100.0% of the voltage or current input corresponding setting refers to the relative (maximum output frequency F0-10) percentage. The 2-point curve takes curve 1 as an example, and the detailed parameters and description are as follows:

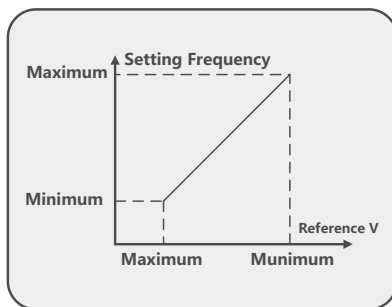

A1 filter time is used to set the software filter time of AI1 . The larger the filter time is, the stronger the anti-interference ability will be, but the response speed to analog detection will be slower.

F5-18	AI curve 2 minimum input	Factory default	0.00V	Attributes	<input type="radio"/>
	Predetermined area	0.00V~F5-20			
F5-19	AI curve 2 minimum input corresponding setting	Factory default	0.0%	Attributes	<input type="radio"/>
	Predetermined area	-100.0%~+100.0%			
F5-20	A1 Curve 2 Maximum Input	Factory default	10.00V	Attributes	<input type="radio"/>
	Predetermined area	F5-18 ~+10.00V			
F5-21	AI curve 2 maximum input corresponding setting	Factory default	100.0%	Attributes	<input type="radio"/>
	Predetermined area	-100.0%~150.0%			
F5-22	AI2 filter time	Factory default	0.10s	Attributes	<input type="radio"/>
	Predetermined area	0.00s~10.00s			

For the function and usage of curve 2, please refer to the description of curve 1.

F5-23	AI curve 3 minimum input	Factory default	-10.00V	Attributes	<input type="radio"/>
	Predetermined area	0.00V~F5-25			
F5-24	AI curve 3 minimum input corresponding setting	Factory default	-100.0%	Attributes	<input type="radio"/>
	Predetermined area	-100.0%~+100.0%			
F5-25	A1 Curve 3 Maximum Input	Factory default	10.00V	Attributes	<input type="radio"/>
	Predetermined area	F5-23 ~+10.00V			
F5-26	AI curve 3 maximum input corresponding setting	Factory default	100.00%	Attributes	<input type="radio"/>
	Predetermined area	-100.0%~+150.0%			
F5-27	AI3 filter time	Factory default	0.10s	Attributes	<input type="radio"/>
	Predetermined area	0.00s~10.00s			

For the function and usage of curve 3, please refer to the description of curve 1.

F5-28	Pulse input minimum frequency	Factory default	0.00KHz	Attributes	○
	Predetermined area	0.00KHz ~F5-30			
F5-29	Pulse minimum input frequency corresponding setting	Factory default	0.00%	Attributes	○
	Predetermined area	-100.0%~+100.0%			
F5-30	Pulse maximum input frequency	Factory default	50.00kHz	Attributes	○
	Predetermined area	F5-28 ~ 100.00kHz			
F5-31	Corresponding setting of pulse maximum input frequency	Factory default	100.00%	Attributes	○
	Predetermined area	-100.0%~+100.0%			
F5-32	Pulse filter time	Factory default	0.10s	Attributes	○
	Predetermined area	0.00s~10.00s			

This function code is used to set the relationship between HDI pulse frequency and corresponding setting. The pulse frequency can only be input to the inverter through the HDI channel.

The application of this group of functions is similar to curve 1, please refer to the description of curve 1.

F5-33	AI curve selection	Factory default	321	Attributes	○
	Predetermined area	ones place	AI1 curve selection		
		1	Curve 1 (2 points, see F5-13~F5-16 )		
		2	Curve 2 (2 points, see F5-18 ~F5-21)		
		3	Curve 3 (2 points, see F5-23 ~ F5-26)		
		4	Curve 4 (4 points, see A0-00~A0-07 )		
		5	Curve 5 (4 points, see A0-08~A0-15 )		
		ten	AI2 curve selection (1~5, same as above)		
hundreds	AI3 curve selection (1~5, same as above)				

the setting curve corresponding to the analog input AI1 , AI2 and AI2 . Any one of the 5 curves can be selected for the 3 analog curves.

Curve 1, curve 2, and curve 3 are all 2-point curves, which need to be set in the function code of group F5, while curve 4 and curve 5 are all 4-point curves, which need to be set in the function code of group A0 .

NVF3 inverter provide 2 channels of analog input, and A I3 needs to be equipped with a multi-functional input and output expansion card.

F5-34	AI below minimum input setting selection	Factory default	000	Attributes	○
	Predetermined area	ones place	AI1 below minimum setting selection		
		0	Corresponding minimum input setting		
		1	0.0%		
		ten	AI2 is lower than the minimum input setting selection (0~1, same as above)		
		hundreds	AI3 is lower than the minimum input setting selection (0~1, same as above)		

This function code is used to set how to determine the corresponding setting of the analog quantity when the voltage of the analog quantity input is less than the set "minimum input".

The ones, tens and hundreds of the function code. Corresponding to analog input AI1, AI2, AI3 respectively.

When the AI input is lower than the minimum input, when 0 is selected, the corresponding setting of the analog quantity is the "minimum input corresponding setting" set by the function code; when 1 is selected, the corresponding setting of the analog quantity is 0.0%.

F5-35	X1 delay time	Factory default	0.0s	Attributes	<input type="radio"/>
	Predetermined area	0.0s~ 3600.0s			
F5-36	X2 delay time	Factory default	0.0s	Attributes	<input type="radio"/>
	Predetermined area	0.0s~ 3600.0s			
F5-37	X3 delay time	Factory default	0.0s	Attributes	<input type="radio"/>
	Predetermined area	0.0s~ 3600.0s			

This function code is used to set the delay time for the X terminal to change its state. Currently X4 and HDI do not have this function.

F5-38	X terminal effective mode selection	Factory default	00000	Attributes	<input checked="" type="radio"/>	
	Predetermined area	ones place	X1 terminal valid state setting			
		0	active high			
		1	active low			
		ten	X2 terminal (0~1, same as above)			
		hundreds	X3 terminal (0~1, same as above)			
		thousands	X4 terminal valid state setting (0~1, same as above)			
ten thousand and bits	HDI terminal effective state setting (0~1, same as above)					

This function code is used to set the valid state mode of the digital input terminal.

When 0 is selected, the connection between the COM terminal and the X terminal is valid, and the disconnection is invalid;

When 1 is selected, the connection between the COM terminal and the X terminal is invalid, and the disconnection is valid;

F5-41	AI1 measured voltage 1	Factory default	factory calibration	Attributes	<input type="radio"/>
	Predetermined area	-10.00 V ~ 10.00V			
F5-42	AI1 display voltage 1	Factory default	factory calibration	Attributes	<input type="radio"/>
	Predetermined area	-10.00 V ~ 10.00V			
F5-43	AI1 measured voltage 2	Factory default	factory calibration	Attributes	<input type="radio"/>
	Predetermined area				

F5-44	AI1 display voltage 2	Factory default	factory calibration	Attributes	○
	Predetermined area	-10.00V ~ 10.00V			
F5-45	AI2 measured voltage 1	Factory default	factory calibration	Attributes	○
	Predetermined area	-10.00V ~ 10.00V			
F5-46	AI2 shows voltage 1	Factory default	factory calibration	Attributes	○
	Predetermined area	-10.00V ~ 10.00V			
F5-47	AI2 measured voltage 2	Factory default	factory calibration	Attributes	○
	Predetermined area	-10.00V ~ 10.00V			
F5-48	AI2 display voltage 2	Factory default	factory calibration	Attributes	○
	Predetermined area	-10.00V ~ 10.00V			
F5-49	AI3 measured voltage 1	Factory default	factory calibration	Attributes	○
	Predetermined area	-10.00V ~ 10.00V			
F5-50	AI3 shows voltage 1	Factory default	factory calibration	Attributes	○
	Predetermined area	-10.00V ~ 10.00V			
F5-51	AI3 measured voltage 2	Factory default	factory calibration	Attributes	○
	Predetermined area	-10.00V ~ 10.00V			
F5-52	AI3 display voltage 2	Factory default	factory calibration	Attributes	○
	Predetermined area	-10.00V ~ 10.00V			

This group of function codes is used to correct the analog AI to eliminate the influence of the zero offset and gain of the AI input port.

The parameters of this group of function codes have been calibrated before leaving the factory. When the factory value is restored, it will return to the value after factory calibration. Generally, no modification is required at the application site.

The measured voltage refers to the actual voltage measured by a multimeter and other measuring instruments, and the displayed voltage refers to the voltage display value sampled by the inverter. See the display of the voltage before AI correction in group U0 (U0-21, U0-22, U0-23).

When calibrating, input two voltage values at each AI input port, and respectively input the value measured by the multimeter and the value read by U0 group into the above function codes, then the inverter will automatically carry out the zero offset and Gain correction. For occasions where the user's given voltage does not match the actual sampling voltage of the inverter, on-site calibration can be used to make the sampling value of the inverter consistent with the expected given value. Taking AI1 as an example, the on-site calibration method is as follows:

1. Given AI1 voltage signal (about 2V)
2. Measure the voltage value of AI1 and record it as V1
3. Check the display value of U0-21 and record it as V2
4. Given AI1 voltage signal (about 8V)
5. Measure the voltage value of AI1 and record it as V3
6. Check the display value of U0-21 and record it as V4
7. Store parameter V1 into parameter F5-41, store V2 into parameter F5-42, store V3 into parameter F5-43, and store V4 into parameter F5-44

When calibrating AI2 and AI3, the actual sampling voltage viewing positions are U0-22 and U0-23 respectively. For AI1 and AI2, it is recommended to use two points of 2V and 8V as calibration points. For AI3, it is recommended to sample two points of -8V and 8V as calibration points. point .



F5-53	AI2 measured current 1	Factory default	factory calibration	Attributes	<input type="radio"/>
	Predetermined area	0mA ~ 20.000mA			
F5-54	AI2 shows current 1	Factory default	factory calibration	Attributes	<input type="radio"/>
	Predetermined area	0mA ~ 20.000mA			
F5-55	AI2 measured current 2	Factory default	factory calibration	Attributes	<input type="radio"/>
	Predetermined area	0mA ~ 20.000mA			
F5-56	AI2 shows current 2	Factory default	factory calibration	Attributes	<input type="radio"/>
	Predetermined area	0mA ~ 20.000mA			

correct the input current of analog AI2 .

The correction method is consistent with the AI2 voltage correction method.

## 12.7 F6 group of output terminals

F6-00	HDO terminal output mode selection	Factory default	0	Attributes	<input type="radio"/>
	Predetermined area	0	High speed pulse output		
		1	switch output		

HDO terminal is a programmable multiplexing terminal, which can be used as a high-speed pulse output terminal or an open-collector switch output terminal.

As a high-speed pulse output terminal, the output pulse can reach up to 100 KHz . For the specific function of HDO , refer to F6-06 description.

F6-01	HDO function selection	Factory default	0	Attributes	<input type="radio"/>
	Predetermined area	0~41			
F6-02	Relay RO1 function selection	Factory default	2	Attributes	<input type="radio"/>
	Predetermined area	0~41			
F6-04	Relay RO2 function selection	Factory default	1	Attributes	<input type="radio"/>
	Predetermined area	0~41			

The above function codes are used to set the functions of the three digital outputs, and the function descriptions of the multi-function output terminals are as follows:

Set value	Function	Illustrate
0	no output	The output terminal has no function
1	Inverter running	Indicates that the inverter is running and has an output frequency (can be zero), at this time the ON signal is output
2	Fault output (fault shutdown)	When the inverter fails and stops due to failure, it will output ON signal.
3	Frequency level detection FDT1 output	Please refer to the description of function codes F8-19 and F8-20.
4	frequency arrival	Please refer to the description of function code F8-21.
5	Running at zero speed (no output when stopped )	When the inverter is running and the output frequency is 0, it will output ON signal. When the inverter is in stop state, this signal is OFF.

6	Motor overload pre-alarm	Before the motor overload protection acts, it judges according to the overload pre-alarm threshold, and outputs ON signal after exceeding the pre-alarm threshold. Refer to function code FE-00 ~ FE-02 for motor overload parameter setting.
7	Inverter overload pre-alarm	10s before the inverter overload protection occurs, output ON signal.
8	Set count pulse arrival	Please refer to the description of function code F9-37 .
9	Arrival of specified count pulse	Please refer to the description of function code F9-38 .
10	length reached	Please refer to the description of function codes F9-34 and F9-35.
11	PLC cycle completed	When the simple PLC completes one cycle, it outputs a pulse signal with a width of 250ms.
12	Cumulative running time reached	When the accumulative running time of the inverter exceeds the time set by F8-17, it will output ON signal.
13	frequency limited	When the set frequency exceeds the upper limit frequency or lower limit frequency, and the output frequency of the inverter reaches the upper limit frequency or lower limit frequency, the ON signal is output.
14	Torque limited	In the speed control mode of the inverter, when the output torque reaches the torque limit value, the inverter is in the stall protection state and outputs ON signal at the same time.
15	ready to run	When the main circuit and control circuit power supply of the frequency converter is stable, and the frequency converter has not detected any fault information, and the frequency converter is in the running state, it outputs ON signal.
16	AI1>AI2	When the value of analog input AI1 is greater than the input value of AI2, it will output ON signal.
17	Upper limit frequency reached	When the running frequency reaches the upper limit frequency, it will output ON signal.
18	The lower limit frequency is reached (no output when stopped)	When the running frequency reaches the lower limit frequency, it will output ON signal. This signal is OFF in stop state.
19	Brown-out status output	When the inverter is in undervoltage state, it will output ON signal.
20	communication control	communication control
21	reserve	reserve
22	reserve	reserve
23	Running at zero speed 2 (also output when stopped)	When the output frequency of the inverter is 0, it outputs ON signal. This signal is also ON in stop state.
24	Accumulated power-on time arrives	the accumulative power-on time ( U0-80) of the inverter exceeds the time set by F8-16, it will output ON signal.
25	Frequency Level Detection FDT2 output	Please refer to the description of function codes F8-28 and F8-29.

26	frequency 1 reach output	Please refer to the description of function codes F8-30 and F8-31.
27	frequency 2 reach output	Please refer to the description of function codes F8-32 and F8-33.
28	electric current 1 reach output	Please refer to the description of function codes F8-38 and F8-39.
29	electric current 2 reach output	Please refer to the description of function codes F8-40 and F8-41.
30	Timing arrival output	When the timing function selection (F8-42) is valid, the inverter will output ON signal after the current running time reaches the set timing time.
31	AI1 input overrun	When the value of analog input AI1 is greater than F8-46 (AI1 input protection upper limit) or less than F8-45 (AI1 input protection lower limit), ON signal is output.
32	Loading	When the inverter is in load-off state, it outputs ON signal.
33	running in reverse	When the inverter is running in reverse, it outputs ON signal
34	zero current state	Please refer to the description of function codes F8-34 and F8-35
35	Module temperature reaches	When the inverter module radiator temperature (U0-75)reaches the set module temperature arrival value (F8-47), the ON signal is output
36	Software current limit exceeded	Please refer to the description of function codes F8-36 and F8-37
37	The lower limit frequency is reached (the output is also output when the machine is stopped)	When the running frequency reaches the lower limit frequency, it will output ON signal. This signal is also ON in the stop state.
38	Alarm output	When the inverter fails and the processing mode of the fault is to continue running, the inverter will output an alarm.
39	reserve	reserve
40	This run time arrives	When the inverter starts to run this time and exceeds the time set by F8-53, it will output ON signal.
41	Fault output	Fault of free stop and no output due to undervoltage.

F6-06	HDO function selection	Factory default	0	Attributes	○
	Predetermined area	0~16			
F6-07	AO1 output function selection	Factory default	0	Attributes	○
	Predetermined area	0~16			
F6-08	AO2 output function selection	Factory default	1	Attributes	○
	Predetermined area	0~16			

HDO terminal output pulse frequency range is 0.01kHz~F6 -09 (HDO output maximum frequency), F6-09 can be set between 0.01kHz~100.00kHz.

The output range of analog quantity output AO1 and AO2 is 0V ~ 10V, or 0mA ~ 20mA . The scaling relationship between the range of pulse output or analog output and the corresponding function is shown in the table below:

Set value	Function	Functional range ( with pulse or analog output 0.0%~100.0% corresponding )
0	operating frequency	0 ~ output frequency
1	set frequency	0 ~ output frequency
2	Output current	0 to 2 times the rated current of the motor
3	Output torque (absolute value)	0 ~ 2 times the rated torque of the motor
4	Output Power	0 ~ 1 times the rated power of the motor
5	The output voltage	0 ~ 1.2 times the rated voltage of the inverter
6	PULSE pulse input	0.01kHz ~ 100.00kHz
7	AI1	0V ~ 10V (or 0 ~ 20mA )
8	AI2	0V ~ 10V (or 0 ~ 20mA )
9	AI3	0V ~ 10V (or 0 ~ 20mA )
10	length	0 ~ Maximum setting length
11	count value	0 ~ Maximum count value
12	communication settings	0.0% ~ 100.0%
13	Motor speed	0 ~ The speed corresponding to the maximum output frequency
14	Output current	0.0A ~ 1000.0A
15	The output voltage	0.0V ~ 1000.0V
16	Motor output torque (actual value,relative to the percentage ofthe motor)	-2 Times the rated torque of the motor ~ 2 times the rated torque of the motor

F6-09	HDO output maximum frequency	Factory default	50.00kHz	Attributes	○
	Predetermined area	0.01kHz ~ 100.00kHz			

the upper limit value when the HDO terminal is used as a high-speed pulse output.

F6-10	AO1 zero bias coefficient	Factory default	0.00%	Attributes	○
	Predetermined area	-100.0% ~ + 100.0%			
F6-11	AO1 gain	Factory default	1	Attributes	○
	Predetermined area	-10.00 ~ +10.00			
F6-12	AO2 bias coefficient	Factory default	0.00%	Attributes	○
	Predetermined area	-100.0% ~ + 100.0%			
F6-13	AO2 gain	Factory default	1	Attributes	○
	Predetermined area	-10.00 ~ +10.00			

This function code is used to set the zero offset and gain of AO1 and AO2 analog output. When there is a difference between the actual setting and the display of the inverter, this parameter can be used to correct it, and it can also be used to customize the AO curve .

If the zero offset is represented by "a", the gain is represented by k, the actual output is represented by Y, and the standard output is represented by X, then the actual output is :

$$Y = kX + a$$

Among them, the zero bias coefficient of AO1 and AO2 is 100% corresponding to 10V (or 20 mA), and the standard output refers to the output 0V ~ 10V (or 0mA ~ 20 mA) corresponding to the analog output without zero bias and gain correction. quantity.

For example: if the content of the analog output is the running frequency, it is expected that the actual output is 8V when the frequency is 0 , and 3V when the frequency is the maximum , then the gain should be set to "- 0.5 ", and the zero offset should be set to "80%".

F6-17	HDO output delay time	Factory default	0.0s	Attributes	<input type="radio"/>
	Predetermined area	0.0s ~ 3600.0s			
F6-18	RO1 output delay time	Factory default	0.0s	Attributes	<input type="radio"/>
	Predetermined area	0.0s ~ 3600.0s			
F6-19	DO1 output delay time	Factory default	0.0s	Attributes	<input type="radio"/>
	Predetermined area	0.0s ~ 3600.0s			
F6-20	RO2 output delay time	Factory default	0.0s	Attributes	<input type="radio"/>
	Predetermined area	0.0s ~ 3600.0s			
F6-21	Do2 output delay time	Factory default	0.0s	Attributes	<input type="radio"/>
	Predetermined area	0.0s ~ 3600.0s			

the delay time from the occurrence of the state to the actual output change of the HDO output terminal, relay 1, and relay 2.

F6-22	DO output terminal active state selection	Factory default	00000	Attributes	<input type="radio"/>
	Predetermined area	ones place	HDO		
		0	positive logic		
		1	counter logic		
		ten	RO1		
		hundreds	DO1		
		thousands	RO2		
ten thousand and bits	DO2				

This function code is used to set the output logic of HDO output terminal, relay 1 and relay 2.

0: Positive logic, the digital output terminal and the corresponding common terminal are connected to the valid state, and disconnected to the invalid state;

1: Negative logic, the digital output terminal and the corresponding common terminal are connected to an invalid state, and disconnected to a valid state.

F6-24	AO1 target voltage 1	Factory default	factory calibration	Attributes	<input type="radio"/>
	Predetermined area	-10.00 V ~ 10.00V			

F6-25	AO1 measured voltage 1	Factory default	factory calibration	Attributes	○
	Predetermined area	-10.00V ~ 10.00V			
F6-26	AO1 target voltage 2	Factory default	factory calibration	Attributes	○
	Predetermined area	-10.00V ~ 10.00V			
F6-27	AO1 measured voltage 2	Factory default	factory calibration	Attributes	○
	Predetermined area	-10.00V ~ 10.00V			
F6-28	AO2 target voltage 1	Factory default	factory calibration	Attributes	○
	Predetermined area	-10.00V ~ 10.00V			
F6-29	AO2 measured voltage 1	Factory default	factory calibration	Attributes	○
	Predetermined area	-10.00V ~ 10.00V			
F6-30	AO2 target voltage 2	Factory default	factory calibration	Attributes	○
	Predetermined area	-10.00V ~ 10.00V			
F6-31	AO2 measured voltage 2	Factory default	factory calibration	Attributes	○
	Predetermined area	-10.00V ~ 10.00V			
F6-32	AO1 ideal current 1	Factory default	factory calibration	Attributes	○
	Predetermined area	0.000mA ~ 20.000mA			
F6-33	AO1 measured current 1	Factory default	factory calibration	Attributes	○
	Predetermined area	0.000mA ~ 20.000mA			
F6-34	AO1 ideal current 2	Factory default	factory calibration	Attributes	○
	Predetermined area	0.000mA ~ 20.000mA			
F6-35	AO1 measured current 2	Factory default	factory calibration	Attributes	○
	Predetermined area	0.000mA ~ 20.000mA			

The above function codes are used to correct the analog output AO. The above function parameters have been calibrated before leaving the factory, and when the factory value is restored, it will return to the value after factory calibration. Generally, no calibration is required at the application site.

The target voltage refers to the theoretical output voltage value of the inverter. The measured voltage refers to the actual output voltage value measured by instruments such as a multimeter.

## 12.8 F7 group of keyboard and display

F7-00	user password	Factory default	0	Attributes	○
	Predetermined area	0 ~ 65535			

This function code is used to set the user protection password, if any number is set, the password protection function will start. The correct password must be entered when entering the menu next time. Be sure to remember the user password.

If this function code is set to 0, the set user password will be cleared, and the password protection function will be disabled.

F7-01	Nixie tube self-test	Factory default	0	Attributes	<input type="radio"/>
	Predetermined area	0: not examine; 1: all digital tubes lit			

This function code is used for setting, display panel digital tube self-test, when set to 1, all digital tubes light up.

F7-02	MF key function selection	Factory default	0	Attributes	<input type="radio"/>	
	Predetermined area	0	M F function keys are invalid			
		1	Operation panel command channel and remote command channel (terminal command channel or communication command channel)switching			
		2	Forward and reverse switching			
		3	forward jog			
4	reverse jog					

This function code is used to set the function of MF key. This key can be used to switch between stop and run.

0: no function

1: Switch between keyboard commands and remote operation

Refers to the switching of the command source, that is, the switching between the current command source and keyboard control (local operation). If the current command source is keyboard control, the function of this key is invalid.

2 : Forward and reverse switching

Switch the direction of the frequency command through the MF key. This function is only valid when the command source is the command channel of the operation panel.

3: forward jog

Forward rotation jogging (FJOG) can be realized through the MF key on the keyboard.

4: reverse jog

Realize reverse jog (RJOG) through keyboard MF key .

F7-03	STOP/RESET key function	Factory default	1	Attributes	
	Predetermined area	0	only in keyboard mode , STOP/RES The key stop function is valid		
1		in any mode of operation , STOP/RES The key stop function is valid			

	led run display parameters 1	Factory default	1F	Attributes	○
F7-04	Predetermined area	0000~FFFF	<div style="border: 1px solid black; padding: 2px; display: inline-block;">7 6 5 4 3 2 1 0</div>	<ul style="list-style-type: none"> <li>Running Frequency</li> <li>Setting Frequency</li> <li>DC Voltage</li> <li>Output Voltage</li> <li>Output Current</li> <li>Output Power</li> <li>Output Torque</li> <li>DI Status</li> </ul>	
F7-05	led run display parameters 2	Factory default	0	Attributes	○
F7-05	Predetermined area	0000~FFFF	<div style="border: 1px solid black; padding: 2px; display: inline-block;">7 6 5 4 3 2 1 0</div>	<ul style="list-style-type: none"> <li>PID Feedback</li> <li>PLC Stage</li> <li>HDI Input Pulse Frequency(KHz)</li> <li>Feedback frequency(Hz)</li> <li>Rest Running Time</li> <li>AI1 Voltage Before Calibration(V)</li> <li>AI2 Voltage Before Calibration(V)</li> <li>AI3 Voltage Before Calibration(V)</li> </ul>	
			<div style="border: 1px solid black; padding: 2px; display: inline-block;">15 14 13 12 11 10 9 8</div>	<ul style="list-style-type: none"> <li>Motor Speed</li> <li>Current Power On Time(hour)</li> <li>Current Running Time(Min)</li> <li>HDI Pulse Input Frequency(Hz)</li> <li>Communication Setting Value</li> <li>Encoder Speed Feedback(Hz)</li> <li>Main Frequency Display(Hz)</li> <li>Auxiliary Frequency Display(Hz)</li> </ul>	

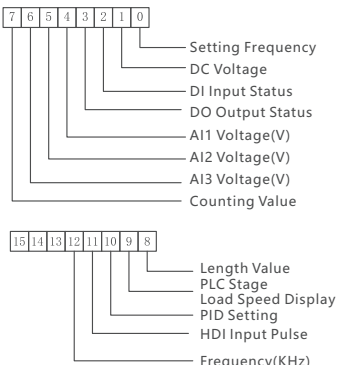

The running display parameters are used to set the parameters that can be viewed when the inverter is in the running state. There are a maximum of 32 status parameters available for viewing, and the status parameters to be displayed are selected according to the binary digits of the F7-04 and F7-05 parameter values, and the display sequence starts from the lowest bit of F7-04.

F7-06	led Shutdown display parameters	Factory default	33	Attributes	<input type="radio"/>
	Predetermined area	0000~FFFF			

F7-07	Load speed display factor	Factory default	1.0000	Attributes	<input type="radio"/>
	Predetermined area	0.001 ~ 6.5000			

When it is necessary to display the load speed, use this parameter to adjust the corresponding relationship between the output frequency of the inverter and the load speed. For specific correspondence, refer to the description of F7-08.

F7-08	Load speed display decimal point	Factory default	twenty one	Attributes	<input type="radio"/>
	Predetermined area	ones place	Number of decimal points for U0-14		
		0	0 decimal display		
		1	1 decimal place display		
		2	2 decimal places display		
		3	3 decimal places display		
		ten	U0-19/ U0-29 Number of decimal points		
		1	1 decimal point		
2	2 decimal points				

This function code is used to set the number of decimal places displayed on the load speed.

For example: load speed display coefficient F7-07 is 2.000, load speed decimal place F7-08 is 2, when the inverter running speed is 40.00Hz, the load speed is  $40.00 \times 2.000 = 80.00$  (2 is the decimal point display); If the inverter is in stop state, the load display speed corresponds to the set frequency.

Tens:

1: U0-19/U0-29 are displayed with 1 decimal point respectively.

2: U0-19/U0-29 are displayed with 2 decimal points respectively

F7-09	Function parameter group display selection		Factory default	11	Attributes	<input type="radio"/>
	Predetermined area	ones place	U group display selection			
		0	Do not show			
		1	show			
		ten	A display selection			
		1	Do not show			
2	show					
F7-10	Personality parameter display options		Factory default	00	Attributes	<input type="radio"/>
	Predetermined area	ones place	User-defined parameter display options			
		0	Do not show			
		1	show			
		ten	User change parameter display selection			
		1	Do not show			
2	show					

The establishment of the parameter display mode is mainly to facilitate the user to view the function parameters in different arrangements according to the actual needs, and three parameter display methods are provided.

Name	Describe
Function parameter mode	The function parameters of the frequency converter are displayed sequentially, including F0~FE , A0 , A5, U0
User-defined parameter mode	The individual function parameters displayed by the user (up to 32 can be customized), and the user determines the function parameters to be displayed through the FF group
How to change parameters by user	Parameters inconsistent with factory parameters

there is one of the individual parameter display selections (F7-10 ), you can switch to different parameter display methods by pressing the Q UICK button. By default, there is only the function parameter method.

The display code of each parameter display mode is:

Parameter display	Show
Full function parameters	- ALL -
User-defined parameters	- -U- -
User changes parameters	- -C- -

NVF3 inverter provides two groups of individual parameter display modes: user-defined parameter mode and user-changed parameter mode. The user-defined parameter group is the parameter set by the user to the FF group, and a maximum of 32 parameters can be selected. These parameters are collected together to facilitate customer debugging.

In the user-defined parameter mode, a symbol u is added by default before the user-defined function code, for example: F1-00, and in the user-defined parameter mode, the display effect is uF1-00 .

The method of changing parameters by the user means that the user has to change the parameters that are different from the factory defaults. The user can change the parameter group to help the customer to view the summary of the changed parameters and find problems on site.

In the mode of user changing parameters, a symbol c is added by default before the user-defined function code, for example: F1-00 , and in the mode of user changing parameters, the display effect is cF1-00 .

F7-11	Parameters change properties	Factory default	0	Attributes	<input type="radio"/>
	Predetermined area	0	Can be modified		
1		Unchangeable			

The function code user sets whether the function code parameters can be modified to prevent the parameters from being modified by mistake.

0: All function codes can be modified;

1: All function codes cannot be modified.

## 12.9 F8 group auxiliary function

F8-00	Jog running frequency	Factory default	2.00Hz	Attributes	<input type="radio"/>
	Predetermined area	0.00Hz ~ maximum frequency			
F8-01	jog acceleration time	Factory default	20.0s	Attributes	<input type="radio"/>
	Predetermined area	0.00s ~ 650.00s(F0-19=2) 0.0s ~ 6500.0s(F0-19=1) 0s ~ 65000s(F0-19=0)			
F8-02	Jog deceleration time	Factory default	20.0s	Attributes	<input type="radio"/>
	Predetermined area	0.00s ~ 650.00s(F0-19=2) 0.0s ~ 6500.0s(F0-19=1) 0s ~ 65000s(F0-19=0)			

In jog operation, the start mode is fixed as direct start, and the stop mode is fixed as deceleration stop.

F8-03	Acceleration time 2	Factory default	Model confirmed	Attributes	<input type="radio"/>
	Predetermined area	0.00s ~ 650.00s(F0-19=2) 0.0s ~ 6500.0s(F0-19=1) 0s ~ 65000s(F0-19=0)			
F8-04	Deceleration time 2	Factory default	Model confirmed	Attributes	<input type="radio"/>
	Predetermined area	0.00s ~ 650.00s(F0-19=2) 0.0s ~ 6500.0s(F0-19=1) 0s ~ 65000s(F0-19=0)			
F8-05	Acceleration time 3	Factory default	Model confirmed	Attributes	<input type="radio"/>
	Predetermined area	0.00s ~ 650.00s(F0-19=2) 0.0s ~ 6500.0s(F0-19=1) 0s ~ 65000s(F0-19=0)			
F8-06	Deceleration time 3	Factory default	Model confirmed	Attributes	<input type="radio"/>
	Predetermined area	0.00s ~ 650.00s(F0-19=2) 0.0s ~ 6500.0s(F0-19=1) 0s ~ 65000s(F0-19=0)			

F8-07	Acceleration time 4	Factory default	0.0s	Attributes	○
	Predetermined area	0.00s ~ 650.00s(F0-19=2) 0.0s ~ 6500.0s(F0-19=1) 0s ~ 65000s(F0-19=0)			
F8-08	Deceleration time 4	Factory default	0.0s	Attributes	○
	Predetermined area	0.00s ~ 650.00s(F0-19=2) 0.0s ~ 6500.0s(F0-19=1) 0s ~ 65000s(F0-19=0)			

Through different combinations of multi-function digital input terminals X, you can switch between acceleration and deceleration time 1 ~ acceleration and deceleration time 4. For specific usage methods, please refer to the X function description section. Among them, in the torque mode of the inverter vector control, the output frequency change corresponds to the acceleration and deceleration time 4, and the default is 0s.

F8-09	jump frequency 1	Factory default	0.00Hz	Attributes	○
	Predetermined area	0.00Hz ~ maximum frequency			
F8-10	jump frequency 2	Factory default	0.00Hz	Attributes	○
	Predetermined area	0.00Hz ~ maximum frequency			
F8-11	Hop Frequency Amplitude	Factory default	0.00Hz	Attributes	○
	Predetermined area	0.00Hz ~ maximum frequency			

When the set frequency is within the jump frequency range, the actual running frequency will run at the jump frequency which is closer to the set frequency. By setting the jump frequency, the inverter can avoid the mechanical resonance point of the load. Two jump frequency points can be set, if both jump frequencies are set to 0Hz, the jump frequency function will be cancelled. The principle of jump frequency and jump frequency amplitude is shown in the figure below:

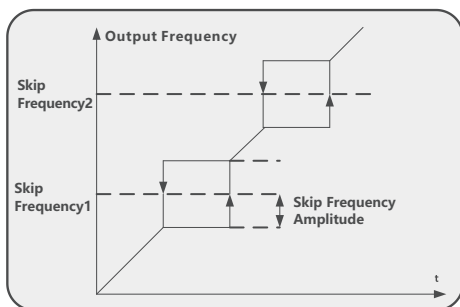

F8-12	Forward and reverse dead time	Factory default	0.0s	Attributes	○
	Predetermined area	0.0s ~ 3000.0s			

This parameter is used to set the holding time for running at 0Hz when the inverter switches from forward (reverse) run to reverse (forward) run.

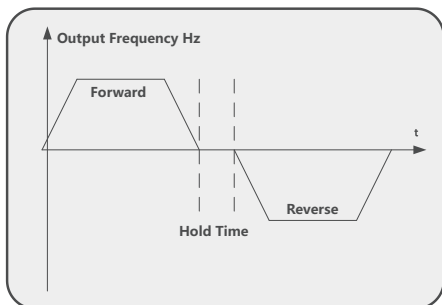

F8-13	Reverse Frequency Prohibited	Factory default	0	Attributes	<input type="radio"/>
	Predetermined area	0	invalid		
		1	efficient		

This parameter is used to set whether the motor is allowed to run in reverse. If the motor is not allowed to run in reverse, it is necessary to set the reverse frequency to be disabled.

F8-14	The set frequency is lower than the lower limit frequency operation mode	Factory default	0	Attributes	<input type="radio"/>
	Predetermined area	0	run at lower frequency		
		1	shutdown		
		2	Zero speed operation		

This parameter can be used to set the running state when the set frequency of the inverter is lower than the lower limit frequency.

F8-15	droop rate	Factory default	0.00%	Attributes	<input type="radio"/>
	Predetermined area	0.00% ~ 10.00%			

In a master-slave control system, the droop rate allows for a slight speed difference between the master and slave stations .

The droop rate needs to be adjusted only when both the master and the slave adopt the speed control mode. The droop rate should be set according to the actual application . It is recommended not to set F8-15 too large, otherwise the steady-state speed will be significantly reduced when the load is large. decline. Both master and slave must set the droop rate.

Droop speed = synchronous frequency × output torque × droop rate ÷ 10

Example : F8-15 = 1.00, synchronous frequency 50Hz, output torque (relative to the rated torque of the motor ) 50%, then:

Droop speed = 50Hz×50%×1.00÷10=2.5Hz

Inverter actual frequency = 50Hz – 2.5Hz = 47.5Hz

F8-16	Set the cumulative power-on arrival ime	Factory default	0h	Attributes	<input type="radio"/>
	Predetermined area	0h ~ 65000h			

When the accumulative power-on time ( U0-80) of the inverter reaches the time set by this parameter, the multi-functional digital DO can be set to output the ON signal.

F8-17	Set the cumulative running arrival time	Factory default	0h	Attributes	<input checked="" type="radio"/>
	Predetermined area	0h ~ 65000h			

When the cumulative running time of the inverter ( U0-77) reaches the time set by this parameter, the multi-functional digital DO can be set to output the ON signal .

F8-18	Boot Protection Selection	Factory default	0	Attributes	<input type="radio"/>
	Predetermined area	0	not protected		
		1	Protect		

This parameter involves the safety protection function of the frequency converter.

If this parameter is set to 1, if the running command is valid when the inverter is powered on or when the fault is reset (for example, the terminal running command is closed before power-on), the inverter will not respond to the running command, and the running command must be canceled once before running. The drive will not respond until the command is valid again.

Setting this parameter to 1 can prevent the danger caused by the motor responding to the running command when the power is turned on or the fault is reset without knowing it.

F8-19	Frequency detection value 1 ( FDT1)	Factory default	50.00Hz	Attributes	<input type="radio"/>
	Predetermined area	0.00Hz ~ maximum frequency			
F8-20	Frequency detection hysteresis rate 1	Factory default	5.0%	Attributes	<input type="radio"/>
	Predetermined area	0.0% ~ 100.0%			

When the operating frequency is higher than the frequency detection value, the inverter multi-function outputs DO output ON signal, and when the frequency is lower than the detection value by a certain frequency value, DO output ON signal is canceled.

The above parameters are used to set the detection value of the output frequency and the hysteresis value of the release of the output action. Among them, F8-20 is the percentage of hysteresis frequency relative to frequency detection value F8-19.

The following figure is a schematic diagram of the FDT function :

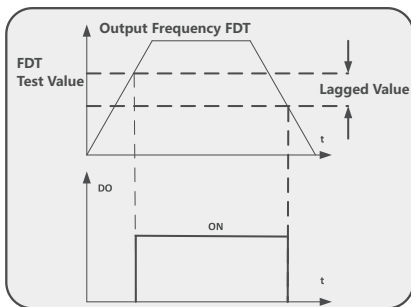

F8-21	Frequency arrival detection width	Factory default	0.0%	Attributes	<input type="radio"/>
	Predetermined area	0.0% ~ 100.0% (maximum frequency)			

The running frequency of the inverter reaches (setting frequency – Frequency reaches detection width) and (set frequency + When the frequency reaches the detection width), the multi-function DO of the inverter will output ON signal. This parameter is the percentage relative to the maximum frequency, and the frequency arrival function is as shown in the figure below:

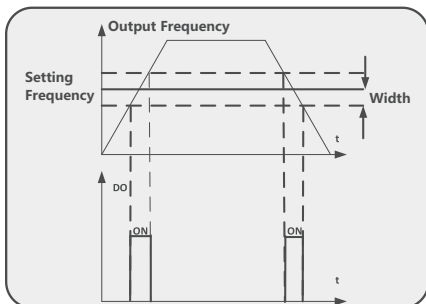

F8-22	Jump frequency during acceleration and deceleration valid choice	Factory default	0	Attributes	<input type="radio"/>
	Predetermined area	0	invalid		
		1	efficient		

When the jump frequency is set to be valid during acceleration and deceleration, the actual running frequency will skip the set jump frequency range during the acceleration or deceleration process of the inverter.

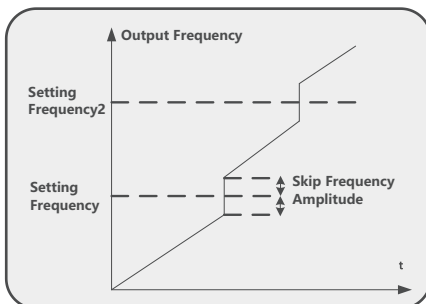

F8-25	Acceleration time 1, 2 switching frequency	Factory default	0.00Hz	Attributes	<input type="radio"/>
	Predetermined area	0.00Hz ~ maximum frequency			

F8-26	Deceleration time 1, 2 switching frequency	Factory default	0.00Hz	Attributes	○
	Predetermined area	0.00Hz ~ maximum frequency			

When the inverter does not select the acceleration and deceleration time through the X terminal, different acceleration and deceleration times can be switched according to the operating frequency.

During acceleration, select acceleration time 2 when the operating frequency is less than F8-25 ; select acceleration time 1 when the operating frequency is greater than F8-25 .

During deceleration, select acceleration time 2 when the operating frequency is less than F8-26 ; select acceleration time 1 when the operating frequency is greater than F8-26

F8-27	Terminal jog priority	Factory default	0	Attributes	○
	Predetermined area	0	invalid		
		1	efficient		

This parameter is used to set whether the terminal jog function has the highest priority. When the terminal jog priority is valid, if a terminal jog command occurs during operation, the inverter will switch to the terminal jog running state

F8-28	Frequency detection value 2 ( FDT2)	Factory default	50.00Hz	Attributes	○
	Predetermined area	0.00Hz ~ maximum frequency			
F8-29	Frequency detection hysteresis rate 2	Factory default	5.0%	Attributes	○
	Predetermined area	0.0% ~ 100.0%			

This function is the same as that of FDT1 , please refer to the related instructions of F8-19 and F8-20 .

F8-30	Arbitrary arrival frequency detection value 1	Factory default	50.00Hz	Attributes	○
	Predetermined area	0.00Hz ~ maximum frequency			
F8-31	Arbitrary arrival frequency detection width 1	Factory default	0.0%	Attributes	○
	Predetermined area	0.0% ~ 100.0% (maximum frequency )			
F8-32	Arbitrary arrival frequency detection value 2	Factory default	50.00Hz	Attributes	○
	Predetermined area	0.00Hz ~ maximum frequency			
F8-33	Arbitrary arrival frequency detection width 2	Factory default	0.0%	Attributes	○
	Predetermined area	0.0% ~ 100.0% (maximum frequency )			

The running frequency of the frequency converter reaches (arbitrary frequency– frequency reach detection width) and (arbitrary frequency + When the frequency reaches the detection width) , the multi-function DO of the inverter will output ON signal. Arbitrary frequency arrival detection function as shown in the figure below:



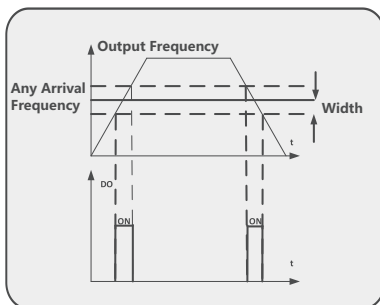

F8-34	Zero current detection level	Factory default	5.0%	Attributes	<input type="radio"/>
	Predetermined area	0.0% ~ 300.0% (motor rated current )			
F8-35	Zero current detection delay time	Factory default	0.10s	Attributes	<input type="radio"/>
	Predetermined area	0.01s ~ 600.00s			

When the output current of the inverter is less than or equal to the zero current detection level, and the duration exceeds the zero current detection delay time, the multi-function DO of the inverter outputs ON signal. Zero current detection is shown in the figure:

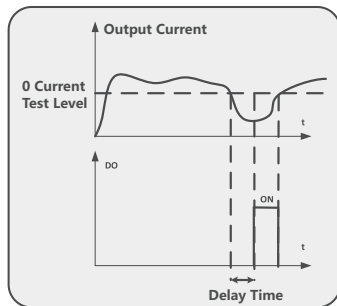

F8-36	Output current exceeds limit	Factory default	200.0%	Attributes	<input type="radio"/>
	Predetermined area	0.0% ~ 300.0% (motor rated current )			
F8-37	Output current overrun delay time	Factory default	0.00s	Attributes	<input type="radio"/>
	Predetermined area	0.00s ~ 600.00s			

When the output current of the inverter is greater than or equal to the over-limit detection point, and the duration exceeds the software over-current point detection delay time, the multi-function DO of the inverter outputs an ON signal, and the output current over-limit function is shown in the figure:

When F8-36 current limit value is set to 0.0 % , it will not be detected.

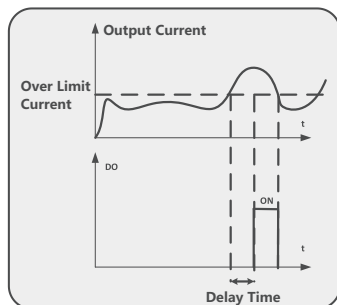

F8-38	Arbitrary arrival current 1	Factory default	100.0%	Attributes	<input type="radio"/>
	Predetermined area	0.0% ~ 300.0% (motor rated current)			
F8-39	Arbitrary reaching current 1 amplitude	Factory default	0.0%	Attributes	<input type="radio"/>
	Predetermined area	0.0% ~ 300.0% (motor rated current)			
F8-40	Arbitrary arrival current 2	Factory default	100.0%	Attributes	<input type="radio"/>
	Predetermined area	0.0% ~ 300.0% (motor rated current)			
F8-41	Arbitrary reaching current 2 amplitude	Factory default	0.0%	Attributes	<input type="radio"/>
	Predetermined area	0.0% ~ 300.0% (motor rated current)			

When the output current of the inverter is within the positive and negative detection width of any set current, the multi-function DO of the inverter outputs ON signal.

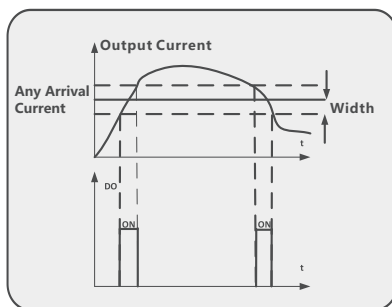

F8-42	Timing function selection	Factory default	0	Attributes	<input type="radio"/>
	Predetermined area	0	invalid		
		1	efficient		

F8-43	Timing run time selection	Factory default	0	Attributes	<input type="radio"/>	
	Predetermined area	0	F8-44 setting			
		1	AI1			
		2	AI2			
	3	AI3				
F8-44	Timing run time	Factory default	0.0Min	Attributes	<input type="radio"/>	
	Predetermined area	0.0Min ~ 6500.0Min				

Timing function :

When the timing function is valid, the frequency converter starts counting from 0 every time it starts running. After reaching the set timing running time, the frequency converter will stop automatically. If the digital multi-function DO or relay output selects the < timed arrival > function, it will output ON signal. The remaining running time can be viewed through U0-20 .

100% in F8-43 parameter corresponds to the setting time of F8-44 .

F8-45	AI1 input voltage protection value lower limit	Factory default	3.10V	Attributes	<input type="radio"/>
	Predetermined area	0.00V ~ F8-46			
F8-46	AI1 input voltage protection upper limit	Factory default	6.80V	Attributes	<input type="radio"/>
	Predetermined area	F8-45 ~ 11.00V			

If the digital multi-function DO or relay output selects <AI1 input overrun> function, when the analog AI1 input voltage (after calibration ) is greater than F8-46 , or the AI1 input is less than F8-45 , DO Output ON signal.

F8-47	Module temperature reaches	Factory default	75°C	Attributes	<input type="radio"/>
	Predetermined area	0°C ~ 100°C			

If the digital multi-function DO or the relay output selects the <module temperature arrival > function, when the temperature of the inverter module reaches the set temperature, DO outputs an ON signal.

F8-48	Cooling Fan Control	Factory default	0	Attributes	<input type="radio"/>
	Predetermined area	0	Fan running while running		
1		fan keeps running			

Fan control mode 0: The fan runs when the inverter is running. In shutdown state, when the temperature of the radiator is higher than 40 ° C , the fan continues to run; when the temperature of the radiator is lower than 40°C , the fan stops running.

Fan control mode 1 : The fan keeps running after it is powered on.

F8-49	wakeup frequency	Factory default	0.00Hz	Attributes	<input type="radio"/>
	Predetermined area	F8-51 ~ maximum frequency			
F8-50	wake up delay time	Factory default	0.0s	Attributes	<input type="radio"/>
	Predetermined area	0.0s ~ 6500.0s			

F8-51	sleep frequency	Factory default	0.00Hz	Attributes	<input type="radio"/>
	Predetermined area	0.00Hz ~ F8-49			
F8-52	sleep delay time	Factory default	0.0s	Attributes	<input type="radio"/>
	Predetermined area	0.0s ~ 6500.0s			

During the operation of the inverter, when the set frequency is less than or equal to the sleep frequency of F8-51, after the delay time of F8-52, the inverter will enter the sleep state and stop automatically. If the inverter is in sleep state and the current running command is valid, when the set frequency is greater than or equal to the wake-up frequency of F8-49, the inverter will start after the delay time of F8-50. If both the wake-up frequency and sleep frequency are set to 0.00Hz, the sleep and wake-up functions will be invalid.

Note: When the dormancy function is enabled, if the frequency source uses PID, it must select the operation when PID stops ( F9-28) .

F8-53	Arrival time for this run	Factory default	0.0Min	Attributes	<input checked="" type="radio"/>
	Predetermined area	0.0Min ~ 6500.0Min			

If the digital multi-functional DO or relay output selects the function of <current running time reached > , when the current running time of the inverter reaches the set time, DO outputs ON signal.

F8-54	Output power correction factor	Factory default	100 . 0%	Attributes	<input type="radio"/>
	Predetermined area	0.0% ~ 200.0%			

This parameter is used to correct the output power displayed by U0-05 .

F8-55	D PWM switching upper limit frequency	Factory default	8.00Hz	Attributes	<input type="radio"/>
	Predetermined area	5.00Hz ~ maximum frequency			

When the operating frequency is lower than this set value, it is CPWM modulation mode, and when it is higher than this set value, it is DPWM modulation mode. If the carrier frequency is set to be less than or equal to 2KHz, the debugging method is fixed as CPWM modulation.

The CPWM modulation mode has large switching loss and small current ripple; the DPWM modulation mode has small switching loss and large current ripple.

F8-56	PWM modulation method	Factory default	0	Attributes	<input type="radio"/>
	Predetermined area	0	asynchronous modulation		
		1	synchronous modulation		

In the V/F control mode, when the output frequency of the inverter is high, in order to ensure the quality of the output voltage, it is necessary to select synchronous modulation, so that the carrier frequency changes with the output frequency, and the carrier ratio remains unchanged.

the operating frequency is higher than 85Hz , the synchronous modulation will take effect, and it will be fixed as asynchronous modulation when it is lower than 85Hz .

F8-58	Random PWM Depth	Factory default	0	Attributes	<input type="radio"/>
	Predetermined area	0	invalid		
		1~10	random depth adjustment		

When the random depth adjustment is enabled, the carrier frequency output by the inverter can be changed and adjusted within a certain range, which is beneficial to reduce external electromagnetic interference.

F8-59	Fast current limit enable	Factory default	1	Attributes	<input type="radio"/>
	Predetermined area	0	not enabled		
		1	Enable		

Enabling the fast current limiting function can minimize the overcurrent fault of the inverter and ensure the uninterrupted operation of the inverter. If the inverter is in the state of rapid current limiting for a long time, the inverter may be damaged by overheating, which is not allowed, so the inverter will report fault E.CBC and stop when it is in the state of rapid current limiting for a long time.

### 12.10 F9 group of PID functions

PID control is a common method of process control. By performing proportional, integral and differential operations on the difference between the feedback signal of the controlled quantity and the target signal, and adjusting the output frequency of the inverter, a closed-loop system is formed to stabilize the controlled quantity at target value.

It is suitable for process control occasions such as flow control, pressure control and temperature control. The following figure shows the functional block diagram of PID control .

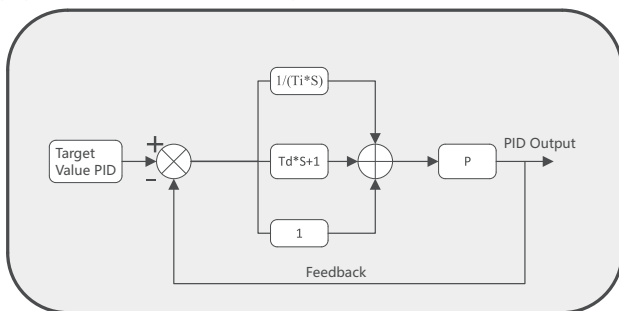

F9-00	PID given source	Factory default	0	Attributes	<input type="radio"/>
	Predetermined area	0	F9-01 setting		
		1	AI1		
		2	AI2		
		3	AI3		
		4	pulse setting HDI		
		5	communication setting		
	6	multi-segment command			
F9-01	PID value given	Factory default	50.0%	Attributes	<input type="radio"/>
	Predetermined area	0.0% ~ 100.0%			

This function code is used to set the target quantity given channel of process PID.

The set target quantity of process PID is a relative value, and the setting range is 0.0%~100.0%. Similarly, the feedback quantity of PID is also a relative quantity, and the function of PID is to make the two relative quantities the same.

F9-02	PID Feedback Source	Factory default	0	Attributes	<input type="radio"/>	
	Predetermined area	0	AI1			
		1	AI2			
		2	AI3			
		3	AI1 - AI2			
		4	HDI pulse			
		5	communication setting			
		6	AI1 + AI2			
		7	MAX ( AI1 , AI2 )			
8	M IN( AI1 , AI2 )					

This parameter is used to select the feedback signal channel of the process PID.

The feedback value of the process PID is also a relative value, and the setting range is 0.0%~100.0%.

F9-03	PID action direction	Factory default	0	Attributes	<input type="radio"/>
	Predetermined area	0	positive effect		
1		reaction			

This function code is used to set the action direction of the process PID .

Positive action: when the feedback is greater than the given value, the PID output control amount decreases.

Reaction: When the feedback is greater than the given value, the PID output control amount increases.

When using this function, it is also necessary to combine the influence of the multi-function terminal PID function inversion (function 35).

F9-04	PID given feedback	Factory default	1000	Attributes	<input type="radio"/>
	Predetermined area	0 ~ 65535			

This function code is used for PID given display U0-15 and U0-16 . For example, if F9-04 is set to 5000, when PID reference is 100.0%, PID reference will display U0-15 as 5000.

F9-05	Proportional gain Kp1	Factory default	20.0	Attributes	<input type="radio"/>
	Predetermined area	0.0 _ ~ 1000.0			
F9-06	Integration time Ti1	Factory default	2.00s	Attributes	<input type="radio"/>
	Predetermined area	0.01s ~ 10.00s			
F9-07	Derivative time Td1	Factory default	0.000s	Attributes	<input type="radio"/>
	Predetermined area	0.00 ~ 10.000			

#### 1) Proportional gain Kp1:

Determine the adjustment strength of the entire PID regulator, the greater the Kp1, the greater the adjustment strength. The parameter 100.0 means that when the deviation between the PID feedback quantity and the given quantity is 100.0%, the adjustment range of the PID regulator to the output frequency command is the maximum frequency.

#### 2) Integration time Ti1:

Determine the strength of integral regulation of PID regulator. The shorter the integration time, the greater the adjustment intensity. The integral time means that when the deviation between the PID feedback amount and the given amount is 100.0%, the integral regulator will continue to adjust after this time, and the adjustment amount will reach the maximum frequency.

## 3) Derivative time Td1:

Determine the strength of the PID regulator to adjust the deviation change rate. The longer the differential time, the greater the adjustment intensity. Differential time means that when the feedback quantity changes 100.0% within this time, the adjustment quantity of the differential regulator is the maximum frequency.

F9-08	PID inversion cut-off frequency	Factory default	0.00	Attributes	<input type="radio"/>
	Predetermined area	0.00 ~ maximum frequency			

ID output frequency of the inverter .

F9-09	PID deviation limit	Factory default	0.0%	Attributes	<input type="radio"/>
	Predetermined area	0.0% ~ 100.0%			

This function code is used to set the minimum effective deviation of PID. When the deviation between PID given value and feedback value is less than F9-09 , PID will stop adjusting.

F9-10	PID Differential Limiter	Factory default	0.10%	Attributes	<input type="radio"/>
	Predetermined area	0.00% ~ 100.00%			

This function code is used to set the range of PID differential output, prevent system oscillation caused by too sensitive differential adjustment, and limit the differential action of PID to a smaller range.

F9-11	PID given change time	Factory default	0.00s	Attributes	<input type="radio"/>
	Predetermined area	0.00s ~ 650.00s			

This function code is used to set the time required for the PID given value to change from 0.0% to 100.0%. When the PID setting changes, the PID setting value changes linearly according to the given change time to prevent the given mutation from causing adverse effects on the system.

F9-12	PID feedback filter time	Factory default	0.00s	Attributes	<input type="radio"/>
	Predetermined area	0.00s ~ 60.00s			
F9-13	PID output filter time	Factory default	0.00s	Attributes	<input type="radio"/>
	Predetermined area	0.00s ~ 60.00s			

The above function codes are used to set the PID feedback amount filter and PID output filter respectively.

PID feedback quantity filtering is beneficial to reduce the influence of feedback quantity being disturbed, but it will reduce the response performance of the process PID control system .

PID output filtering will weaken the sudden change in the output frequency of the inverter, but it will also reduce the response performance of the process PID control system .

F9-15	Proportional gain Kp 2	Factory default	20.0	Attributes	<input type="radio"/>
	Predetermined area	0.0 _ ~ 1000.0			
F9-16	Integration time Ti 2	Factory default	2.00s	Attributes	<input type="radio"/>
	Predetermined area	0.01s ~ 10.00s			
F9-17	Derivative time Td 2	Factory default	0.000s	Attributes	<input type="radio"/>
	Predetermined area	0.00 ~ 10.000			

F9-18	PID parameter switch condition	Factory default	0	Attributes	<input type="radio"/>	
	Predetermined area	0	do not switch			
		1	Switch by X terminal			
		2	Automatic switching according to deviation			
	3	Automatic switching according to operating frequency				
F9-19	PID parameter switching deviation 1	Factory default	20.0%	Attributes	<input type="radio"/>	
	Predetermined area	0.0% ~ F9-20				
F9-20	PID parameter switching deviation 2	Factory default	80.0%	Attributes	<input type="radio"/>	
	Predetermined area	F9-19 ~ 100.0%				

In some applications, a set of PID parameters cannot meet the requirements of the entire operation process, and different PID parameters need to be used in different situations.

This group of function codes is used for switching between two groups of PID parameters. The setting method of regulator parameters F9-15~F9-17 is similar to that of parameters F9-05~F9-07 .

F9-18 function code is used to set the switching conditions of PID parameters.

When F9-18 is equal to 0, PID parameters will not be switched. When F9-18 is equal to 1, the function selection of the multi-function terminal should be set to 43 (PID parameter switching terminal). When this terminal is invalid, select parameter group 1 (F9-05~F9-07), and when the terminal is valid, select parameter group 2 ( F9-15 ~F9-17 ) .

When F9-18 is equal to 2, when the absolute value of the deviation between reference and feedback is less than PID parameter switching deviation 1 ( F9-19 ), the PID parameter selects parameter group 1. When the absolute value of the deviation between reference and feedback is greater than PID switching deviation 2 ( F9-20), select parameter group 2 for PID parameter selection. When the deviation between reference and feedback is between switching deviation 1 and switching deviation 2, the PID parameters are the linear interpolation values of two sets of PID parameters, as shown in the figure below.

When F9-18 is equal to 3, the PID parameter has a linear relationship with the current operating frequency, 0Hz corresponds to PID parameter 1, and the maximum output frequency corresponds to PID parameter 2.

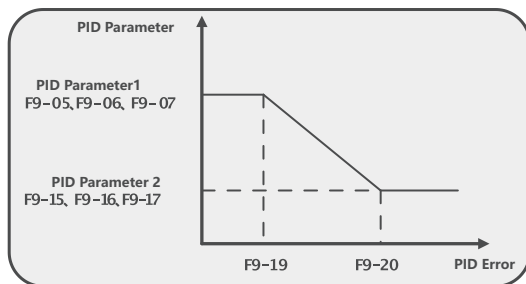

F9-21	PID initial value	Factory default	0.0%	Attributes	<input type="radio"/>
	Predetermined area	0.0% ~ 100.0%			
F9-22	PID initial value hold time	Factory default	0 . 00s	Attributes	<input type="radio"/>
	Predetermined area	0.00s ~ 650.00s			



After running the inverter, the PID output is fixed at the initial value of PID, and after the PID initial value operation continues for the PID initial value holding time, the PID enters the regulation operation. The following figure is a schematic diagram of the PID initial value function for starting the inverter.

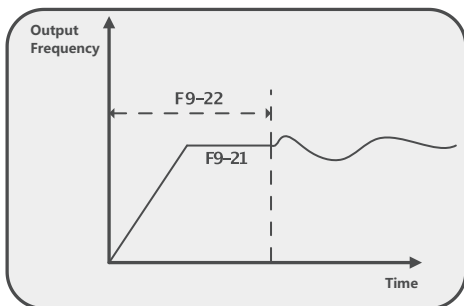

F9-23	The maximum value of the positive direction of the two output deviations	Factory default	1.00 %	Attributes	<input type="radio"/>
	Predetermined area	0.00 % ~ 100.00 %			
F9-24	The reverse maximum value of the two output deviations	Factory default	1.00 %	Attributes	<input type="radio"/>
	Predetermined area	0.00 % ~ 100.00 %			

This group of parameters is used to limit the difference between the two PID control outputs to achieve the effect of inhibiting the PID output from changing too fast.

F9-25	PID integral attribute	Factory default	00	Attributes	<input type="radio"/>	
	Predetermined area	ones place	Integral separation			
		0	invalid			
		1	efficient			
		ten	Whether to stop integration after the output reaches the limit			
		0	keep scoring			
1	stop points					

Ones place: Control whether the PID integration is valid or not. When the multi-function terminal selects integral pause (function 38) to be valid, if the ones place is 1, the PID integration stops running.

Tens place: When set to 1, the integral calculation will be stopped after the PID operation output reaches the maximum or minimum value, which helps to reduce the PID overshoot.

F9-26	PID feedback loss detection value	Factory default	0.0%	Attributes	<input type="radio"/>
	Predetermined area	0.0%: no judgment on feedback loss; 0.1% ~ 100.0%			
F9-27	PID feedback loss detection time	Factory default	0.0s	Attributes	<input type="radio"/>
	Predetermined area	0.0s ~ 20.0s			

This function code is used to set whether to detect PID feedback loss. When the PID feedback amount is less than the F9-26 feedback loss detection value, and the duration is longer than the setting time of F9-27, the inverter will report "E.FBL" feedback loss fault.

F9-28	PID downtime	Factory default	0	Attributes	<input type="radio"/>
	Predetermined area	0	stop running		
		1	shutdown operation		

PID continues to operate when the inverter is stopped. Generally, the PID stops computing in the stop state.

F9-29	PID super value detection value	Factory default	0.0%	Attributes	<input type="radio"/>
	Predetermined area	0.0%: Do not judge the value of the feedback; 0.1% ~ 100.0%			
F9-30	PID value detection time	Factory default	0.0s	Attributes	<input type="radio"/>
	Predetermined area	0.0s ~ 20.0s			

This function code is used to set whether to detect PID feedback overvalue.

When the PID feedback amount is greater than the F9-29 feedback over-value detection value, and the duration is longer than the setting time of F9-30, the inverter will report "E.FBH" feedback over-value fault.

F9-34	set length	Factory default	1000m	Attributes	<input type="radio"/>
	Predetermined area	0m ~ 65535m			
F9-35	Actual length	Factory default	0m	Attributes	<input type="radio"/>
	Predetermined area	0m ~ 65535m			
F9-36	Pulses per meter	Factory default	100.0	Attributes	<input type="radio"/>
	Predetermined area	0.1 ~ 6553.5			

The above function codes are used for fixed length control.

The length information needs to be collected through the multi-function digital input terminal. The number of pulses sampled by the terminal is divided by the number of pulses per meter F9-36, and the actual length F9-35 can be calculated. When the actual length is greater than the set length F9-34, the multifunctional digital outputs the ON signal of "length reached".

During the fixed-length control process, the length reset operation can be performed through the multi-functional X terminal (X function selection is 28), please refer to F5-00~F5-04 for details.

In the application, the corresponding input terminal function needs to be set to "length count input" (function 27). When the pulse frequency is high, the HDI port must be used.

F9-37	set count value	Factory default	1000	Attributes	<input type="radio"/>
	Predetermined area	0 ~ 65535			
F9-38	Specify the count value	Factory default	1000	Attributes	<input type="radio"/>
	Predetermined area	0 ~ 65535			

The count value needs to be collected through the multi-function digital input terminal. In the application, the corresponding input terminal function needs to be set to "counter input" (function 25).

When the pulse frequency is high, the HDI port must be used. When the count value reaches the set count value F9-37, the multi-function digital outputs the ON signal of "set count value arrival", and then the counter stops counting.

When the count value reaches the specified count value F9-38 , the multi-function digital outputs the ON signal of "specified count value arrival", and the counter continues to count at this time, and the counter does not stop until the "set count value".

The specified count value F9-38 should not be greater than the set count value F9-37 . The figure below is a schematic diagram of the functions of setting count value arrival and specified count value arrival.

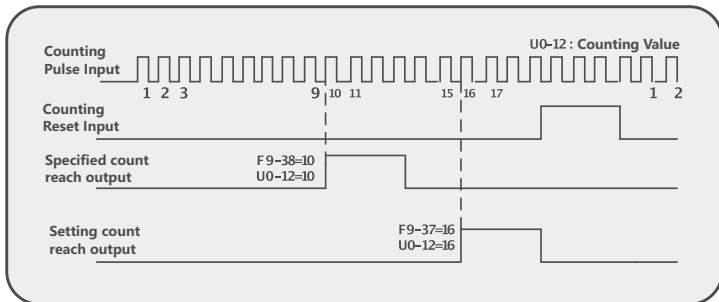

### 12.11 FA group multi-segment instructions, simple PLC function

The multi-stage command of NVF3 has more functions than ordinary multi-stage speed. In addition to realizing the multi-stage speed function, it can also be used as a voltage source for VFseparation and a given source for process PID. The dimensions of multi-segment instructions are relative values.

FA-00	multi-segment instruction 0	Factory default	0.0%	Attributes	<input type="radio"/>
	Predetermined area	-100.0% ~ 100.0%			
FA-01	Multi-segment instruction 1	Factory default	0.0%	Attributes	<input type="radio"/>
	Predetermined area	-100.0% ~ 100.0%			
FA-02	multi-segment instruction 2	Factory default	0.0%	Attributes	<input type="radio"/>
	Predetermined area	-100.0% ~ 100.0%			
FA-03	Multi-stage instruction 3	Factory default	0.0%	Attributes	<input type="radio"/>
	Predetermined area	-100.0% ~ 100.0%			
FA-04	multi-segment instruction 4	Factory default	0.0%	Attributes	<input type="radio"/>
	Predetermined area	-100.0% ~ 100.0%			
FA-05	multi-segment instruction 5	Factory default	0.0%	Attributes	<input type="radio"/>
	Predetermined area	-100.0% ~ 100.0%			
FA-06	Multi-segment instruction 6	Factory default	0.0%	Attributes	<input type="radio"/>
	Predetermined area	-100.0% ~ 100.0%			
FA-07	Multi-segment instruction 7	Factory default	0.0%	Attributes	<input type="radio"/>
	Predetermined area	-100.0% ~ 100.0%			

FA-08	Multi-segment instructions 8	Factory default	0.0%	Attributes	<input type="radio"/>
	Predetermined area	-100.0% ~ 100.0%			
FA-09	Multi-segment instructions 9	Factory default	0.0%	Attributes	<input type="radio"/>
	Predetermined area	-100.0% ~ 100.0%			
FA-10	Multi-segment instructions 10	Factory default	0.0%	Attributes	<input type="radio"/>
	Predetermined area	-100.0% ~ 100.0%			
FA-11	Multi-segment instructions 11	Factory default	0.0%	Attributes	<input type="radio"/>
	Predetermined area	-100.0% ~ 100.0%			
FA-12	Multi-segment instruction 12	Factory default	0.0%	Attributes	<input type="radio"/>
	Predetermined area	-100.0% ~ 100.0%			
FA-13	Multi-stage instruction 13	Factory default	0.0%	Attributes	<input type="radio"/>
	Predetermined area	-100.0% ~ 100.0%			
FA-14	Multi-segment instructions 14	Factory default	0.0%	Attributes	<input type="radio"/>
	Predetermined area	-100.0% ~ 100.0%			
FA-15	Multi-segment instruction 15	Factory default	0.0%	Attributes	<input type="radio"/>
	Predetermined area	-100.0% ~ 100.0%			

Multi-segment instructions can be used in three occasions: as a frequency source , as a voltage source for V/F separation, and as a process PID setting source .

In the three applications, the dimension of the multi-stage command is a relative value, ranging from -100.0% to 100.0%. When it is used as a frequency source, it is the percentage of the relative maximum frequency; when it is used as a V/F separation voltage source, it is the percentage relative to the rated voltage of the motor. Percentage; and because the PID setting is originally a relative value, multi-segment instructions do not need dimension conversion as the PID setting source.

Multi-segment instructions need to be switched according to the different states of the multi-function digital X. For details, please refer to the relevant instructions of Group F5 .

FA-16	Simple PLC operation mode	Factory default	0	Attributes	<input type="radio"/>
	Predetermined area	0	Stop at the end of a single run		
		1	Keep the final value at the end of a single run		
		2	keep looping		

The simple PLC function has two functions, as a frequency source or a voltage source for V/F separation.

As shown in the figure below, it is a schematic diagram of PLC acting as a frequency source. When the simple PLC acts as the frequency source, multi-segment frequency N is used as the frequency source, and the positive or negative of FA-00~FA-15 determines the running direction, and if it is negative, it means the inverter runs in reverse.

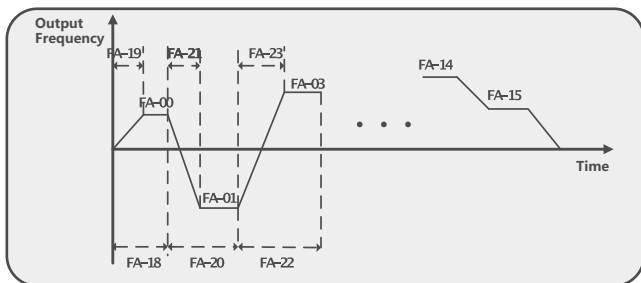

When used as a frequency source, PLC has three operating modes, but it does not have these three modes when used as a V/F separation voltage source. in:

0: stop at the end of a single run

The inverter will stop automatically after completing a single cycle, and will restart only after waiting for the next start command.

1: Keep the final value at the end of a single run

After the inverter completes a cycle, it will keep running at the final running frequency and direction.

2: keep looping

After the inverter completes one cycle, it automatically starts the next cycle.

	Simple PLC power-down memory selection	Factory default	00	Attributes	<input type="radio"/>
FA-17	Predetermined area	ones places	Power-down memory selection		
		0	No memory when power off		
		1	power down memory		
		ten	Shutdown memory selection		
		0	Stop without memory		
		1	shutdown memory		

PLC power-off memory means to memorize the running stage and running frequency of PLC before power-off, and continue to run from the memory stage when power-on next time. If you choose not to memorize, the PLC process will be restarted every time you power on .

PLC shutdown memory means to record the previous PLC operation stage and operation frequency when it is stopped , and continue to run from the memory stage during the next operation . If you choose not to remember, the PLC process will be restarted every time you start up.

FA-18	Running time of stage 0 of simple PLC	Factory default	0.0s(h)	Attributes	<input type="radio"/>
	Predetermined area	0.0s (h) ~ 6500.0s(h)			
FA-19	Simple PLC step 0 acceleration and deceleration time selection	Factory default	0	Attributes	<input type="radio"/>
	Predetermined area	0	Acceleration and deceleration time 1		
		1	Acceleration and deceleration time 2		
		2	Acceleration and deceleration time 3		
		3	Acceleration and deceleration time 4		

FA-20	The running time of the first stage of simple PLC	Factory default	0.0s(h)	Attributes	<input type="radio"/>
	Predetermined area	0.0s(h) ~ 6500.0s(h)			
FA-21	Simple PLC first stage acceleration and deceleration time selection	Factory default	0	Attributes	<input type="radio"/>
	Predetermined area	Same as FA-19			
FA-22	Running time of the second stage of simple PLC	Factory default	0.0s(h)	Attributes	<input type="radio"/>
	Predetermined area	0.0s(h) ~ 6500.0s(h)			
FA-23	Simple PLC second stage acceleration and deceleration time selection	Factory default	0	Attributes	<input type="radio"/>
	Predetermined area	Same as FA-19			
FA-24	Running time of the third stage of simple PLC	Factory default	0.0s(h)	Attributes	<input type="radio"/>
	Predetermined area	0.0s(h) ~ 6500.0s(h)			
FA-25	Simple PLC 3rd stage acceleration and deceleration time selection	Factory default	0	Attributes	<input type="radio"/>
	Predetermined area	Same as FA-19			
FA-26	The running time of the fourth stage of simple PLC	Factory default	0.0s(h)	Attributes	<input type="radio"/>
	Predetermined area	0.0s(h) ~ 6500.0s(h)			
FA-27	Simple PLC step 4 acceleration and deceleration time selection	Factory default	0	Attributes	<input type="radio"/>
	Predetermined area	Same as FA-19			
FA-28	The running time of the fifth stage of simple PLC	Factory default	0.0s(h)	Attributes	<input type="radio"/>
	Predetermined area	0.0s(h) ~ 6500.0s(h)			
FA-29	Simple PLC 5th stage acceleration and deceleration time selection	Factory default	0	Attributes	<input type="radio"/>
	Predetermined area	Same as FA-19			

FA-30	Running time of the sixth stage of simple PLC	Factory default	0.0s(h)	Attributes	<input type="radio"/>
	Predetermined area	0.0s(h) ~ 6500.0s(h)			
FA-31	Simple PLC 6th stage acceleration and deceleration time selection	Factory default	0	Attributes	<input type="radio"/>
	Predetermined area	Same as FA-19			
FA-32	Running time of the seventh stage of simple PLC	Factory default	0.0s(h)	Attributes	<input type="radio"/>
	Predetermined area	0.0s(h) ~ 6500.0s(h)			
FA-33	Simple PLC 7th stage acceleration and deceleration time selection	Factory default	0	Attributes	<input type="radio"/>
	Predetermined area	Same as FA-19			
FA-34	Running time of the 8th stage of simple PLC	Factory default	0.0s(h)	Attributes	<input type="radio"/>
	Predetermined area	0.0s(h) ~ 6500.0s(h)			
FA-35	Simple PLC 8th stage acceleration and deceleration time selection	Factory default	0	Attributes	<input type="radio"/>
	Predetermined area	Same as FA-19			
FA-36	Running time of the 9th stage of simple PLC	Factory default	0.0s(h)	Attributes	<input type="radio"/>
	Predetermined area	0.0s(h) ~ 6500.0s(h)			
FA-37	Simple PLC 9th stage acceleration and deceleration time selection	Factory default	0	Attributes	<input type="radio"/>
	Predetermined area	Same as FA-19			
FA-38	The running time of the 10th stage of simple PLC	Factory default	0.0s(h)	Attributes	<input type="radio"/>
	Predetermined area	0.0s(h) ~ 6500.0s(h)			
FA-39	Simple PLC 10th stage acceleration and deceleration time selection	Factory default	0	Attributes	<input type="radio"/>
	Predetermined area	Same as FA-19			

FA-40	Running time of the 11th stage of simple PLC	Factory default	0.0s(h)	Attributes	<input type="radio"/>
	Predetermined area	0.0s(h) ~ 6500.0s(h)			
FA-41	Simple PLC 11th stage acceleration and deceleration time selection	Factory default	0	Attributes	<input type="radio"/>
	Predetermined area	Same as FA-19			
FA-42	The running time of the 12th stage of simple PLC	Factory default	0.0s(h)	Attributes	<input type="radio"/>
	Predetermined area	0.0s(h) ~ 6500.0s(h)			
FA-43	Simple PLC 12th stage acceleration and deceleration time selection	Factory default	0	Attributes	<input type="radio"/>
	Predetermined area	Same as FA-19			
FA-44	The running time of the 13th stage of simple PLC	Factory default	0.0s(h)	Attributes	<input type="radio"/>
	Predetermined area	0.0s(h) ~ 6500.0s(h)			
FA-45	Simple PLC 13th stage acceleration and deceleration time selection	Factory default	0	Attributes	<input type="radio"/>
	Predetermined area	Same as FA-19			
FA-46	The running time of the 14th stage of simple PLC	Factory default	0.0s(h)	Attributes	<input type="radio"/>
	Predetermined area	0.0s(h) ~ 6500.0s(h)			
FA-47	Simple PLC 14th stage acceleration and deceleration time selection	Factory default	0	Attributes	<input type="radio"/>
	Predetermined area	Same as FA-19			
FA-48	The running time of the 15th stage of simple PLC	Factory default	0.0s(h)	Attributes	<input type="radio"/>
	Predetermined area	0.0s(h) ~ 6500.0s(h)			
FA-49	Simple PLC 15th stage acceleration and deceleration time selection	Factory default	0	Attributes	<input type="radio"/>
	Predetermined area	Same as FA-19			



FA-50	Simple PLC running time unit	Factory default	0	Attributes	<input type="radio"/>	
	Predetermined area	0	S (seconds)			
1		H (hour)				
FA-51	Multi-segment instruction 0 given mode	Factory default	0	Attributes	<input type="radio"/>	
	Predetermined area	0	Function code FA-00 given			
		1	AI1			
		2	AI2			
		3	AI3			
		4	HDI Pulse			
		5	PID			
6	Preset frequency (F0-08 ) given, UP/DOWN can be modified					

This function code is used to set the given channel of multi-segment instruction 0.

In addition to FA-00 for multi-segment command 0, there are many other options for switching between multi-segment command and other given methods . When multi-segment instructions are used as the frequency source or simple PLC is used as the frequency source, the switching of the two frequency sources can be easily realized.

### 12.12 FB group communication parameters

Fb-00	Communication Protocol Selection	Factory default	0	Attributes	<input type="radio"/>
	Predetermined area	0	Modbus-RTU protocol		
1		Profibus-DP , P rofinet , CANopen , EtherCAT protocol			

The inverter uses the serial port to implement Modbus , P rofinet , CANopen , EtherCAT protocols, and only one of these protocols is supported at the same time. Please set this parameter correctly according to actual needs .

Fb-01	Communication baud rate	Factory default	5005	Attributes	○
	Predetermined area	ones place	Modbus		
0		300Bps			
1		600Bps			
2		1200Bps			
3		2400Bps			
4		4800Bps			
5		9600Bps			
6		19200Bps			
7		38400Bps			
8		57600Bps			
9		115200Bps			
ten		Profibus DP、Profinet			
0		115200Bps			
1		208300Bps			
2		256000Bps			
3		512000Bps			
hundreds	reserve				
thousands	reserve				

This parameter is used to set the data transmission rate between the upper computer and the inverter. Note that the baud rate set by the upper computer and the inverter must be consistent, otherwise the communication cannot be carried out. The higher the baud rate, the faster the communication speed.

Ones place: set the standard Modbus communication baud rate of the inverter; tens place: set the communication baud rate on the expansion board.

Fb-02	Modbus data format	Factory default	0	Attributes	○
	Predetermined area	0	No parity ( 8-N-2)		
1		Even parity ( 8-E-1)			
2		odd parity ( 8-O-1)			
3		No parity ( 8-N-1)			

In the Modbus communication mode, the data format set by the upper computer and the inverter must be consistent, otherwise, the communication cannot be carried out.

8-N-2 : 8 data bits, no parity bit, 2 stop bits

8-E-1 : 8 data bits, even parity bit, 1 stop bit

8-O-1 : 8 data bits, odd parity bit, 1 stop bit

8-N-1 : 8 data bits, no parity bit, 1 stop bit

Fb-03	local address	Factory default	1	Attributes	○
	Predetermined area		1 ~ 247		

The local address is unique (except the broadcast address), which is the basis for realizing the point-to-point communication between the upper computer and the frequency converter. When the address sent by the master is 0, it is a broadcast address, and the slave does not need to return data after receiving the broadcast command.

Fb-04	Modbus response delay	Factory default	2ms	Attributes	<input type="radio"/>
	Predetermined area	0 ~ 20ms			

Response delay: refers to the interval between the end of the inverter receiving data and the sending of data to the upper computer. If the response delay is less than the system processing time, the response delay is subject to the system processing time. If the response delay is longer than the system processing time, the system will wait until the response delay time is up before going to the host computer. send data.

This parameter is the response delay set for Modbus communication.

Fb-05	Modbus communication timeout	Factory default	0.0s	Attributes	<input type="radio"/>
	Predetermined area	0.0 ~ 60.0s			

When this function code is set to 0.0s, the communication timeout parameter is invalid. When this function code is set to a valid value, if the interval between one communication and the next communication exceeds the communication timeout time, the system will report a communication failure error ( E.CE ). Normally, it is set to invalid.

Fb-06	data transmission format	Factory default	1	Attributes	<input type="radio"/>
	Predetermined area	ones place	Modbus		
		0	Non-standard Modbus protocol		
1	Standard Modbus protocol				

The non-standard Modbus protocol and the standard Modbus protocol have the following differences when returning communication error codes and reading data instructions:

Return communication error code			Return read data command		
Byte	Non-standard	Standard	Byte	Non-standard	Standard
0	slave address	slave address	0	slave address	slave address
1	function code	0x80 + function code	1	function code	function code
2	0x80	error code	2	data bytes high byte	data bytes
3	0x01	CRC low byte	3	data bytes low byte	Return data N bytes
4	0x00	CRC high byte	4	Return data N bytes	CRC low byte
5	error code		5	CRC low byte	CRC high byte
6	CRC low byte		6	CRC high byte	
7	CRC high byte		7		

Fb-07	Communication current resolution	Factory default	0	Attributes	<input type="radio"/>
	Predetermined area	0	0.01A		
		1	0.1A		

Modbus communication reads the output current of U0-04 , the resolution of the read data can be modified through this parameter. When using the external expansion communication card for communication, the current data read out is fixed at 0.1A resolution .

Fb-09	Expansion card communication interruption detection time	Factory default	0.0s	Attributes	<input type="radio"/>
	Predetermined area	0.0 ~ 60.0s			

When this function code is set to 0.0s, the communication interruption detection parameter is invalid. When this function code is set to a valid value, if the interval between one communication and the next communication exceeds the interruption detection time, the system will report a communication failure error ( E.CE ).

Normally, it is set to invalid.

### 12.13 Fd group expansion card

Fd-00	Encoder lines	Factory default	1024	Attributes	<input type="radio"/>
	Predetermined area	1 ~ 65535			

Set the number of pulses per revolution of the ABZ or UVW incremental encoder. In the vector control mode with speed sensor, the number of encoder pulses must be set correctly, otherwise the motor will run abnormally.

Fd-01	encoder type	Factory default	0	Attributes	<input type="radio"/>
	Predetermined area	0	ABZ incremental encoder		
		2	Resolver		

the encoder type should be correctly selected according to the actual situation , otherwise the inverter may not operate normally.

Fd-03	ABZ incremental encoder AB phase sequence	Factory default	0	Attributes	<input type="radio"/>
	Predetermined area	0	Forward		
		1	reverse		

This function code is only valid for ABZ incremental encoders, that is, only valid when Fd-01=0. It is used to set the phase sequence of the AB signal of the ABZ incremental encoder.

This function code is valid for the asynchronous motor, and the AB phase sequence of the ABZ encoder can be obtained during dynamic tuning of the asynchronous motor.

Fd-07	Resolver pole pairs	Factory default	1	Attributes	<input type="radio"/>
	Predetermined area	1 ~ 65535			

The resolver has the number of pole pairs. When using this kind of encoder, the parameters of the number of pole pairs must be set correctly.

Fd-09	PG disconnection detection time	Factory default	0.0s	Attributes	<input type="radio"/>
	Predetermined area	0.0 s ~ 10.0 s			

It is used to set the detection time of the encoder disconnection fault. When it is set to 0.0s, the inverter will not detect the encoder disconnection fault. When the inverter detects a disconnection fault and the duration exceeds the time set by this parameter , the inverter will alarm E.ENCD.

### 12.14 FE group failure and protection

FE-00	Motor overload protection selection	Factory default	1	Attributes	<input type="radio"/>
	Predetermined area	0	Disable motor overload protection function		
		1	Enable the motor overload protection function		

FE-01	Motor overload protection gain	Factory default	1.00	Attributes	○
	Predetermined area	0.20 ~ 10.00			
FE-02	Motor overload warning coefficient	Factory default	80%	Attributes	○
	Predetermined area	50% ~ 100%			

In order to effectively protect motors with different loads, it is necessary to set the motor overload protection gain according to the motor overload capacity. The motor overload protection is an inverse time-limit curve, and the motor overload protection curve is shown in the figure below:

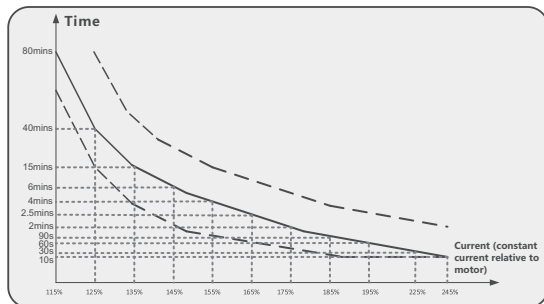

As shown in the figure, the marked operating current point corresponds to the motor overload protection time, and the time between the two points is obtained by linear calculation.

Example: at 1.45 % current, the time to report OL1 is 6 minutes; at 1.55% current, the time to report OL1 is 4 minutes, then the time to report OL1 at 1.50% current is

$$T = 6 + (4 - 6) \times (150\% - 145\%) / (155\% - 145\%) = 5 \text{ (minutes)}$$

Motor overload protection gain:

When the overload protection gain is set to 1.00 by default, when the running current of the motor reaches 175% of the rated current of the motor, the motor overload (OL1) will be reported after 2 minutes of continuous operation; when the running current of the motor reaches 115% of the rated current of the motor, report motor overload (OL1) after 80 minutes of continuous operation.

If it is necessary to modify the overload time according to the motor, adjust the parameters.

Example: The rated current of the motor is 100A. When FE-01=1.00, when the inverter runs to 125A (125%), after 40 minutes, it will report OL1 fault.

If you want the inverter to report OL1 fault after running at 125A for 50 minutes, then set FE-01 = 1.25,  $40 \times 1.25 = 50$  minutes.

If you want the inverter to report OL1 fault after running at 125A for 20 minutes, then set FE-01 = 0.5,  $40 \times 0.5 = 20$  minutes.

Note: The longest overload is 80 minutes, and the shortest overload is 10 seconds.

Motor overload warning coefficient:

send an early warning signal to the control system through DO or relay before the motor overload fault protection. The early warning coefficient is used to determine the extent of early warning before the motor overload protection. The larger the value is, the smaller the advance warning amount is. When the accumulative output current of the inverter is greater than the product of the overload time (the value of the inverse time limit curve of the motor overload protection) and the "motor overload warning coefficient (FE-02)", the inverter multi-functional digital DO output "motor overload pre-alarm" is valid Signal. In special cases, when the motor overload early warning coefficient FE-02 is set to 100%, the early warning advance amount is 0, and at this time the pre-alarm and overload protection occur simultaneously

FE-03	Overvoltage stall gain	Factory default	30	Attributes	<input type="radio"/>
	Predetermined area	0 ~ 100			
FE-04	Overvoltage stall action voltage	Factory default	Model confirmed	Attributes	<input checked="" type="radio"/>
	Predetermined area	380V model: 650.0V~800.0V; 220V model: 320.0V~800.0V			

of parameter FE-03 is the same as that of parameter F4-24 , and the function of parameter FE-04 is the same as that of parameter F4-22 . For detailed description, please refer to the parameters of group F4 .

Note: To enable the overvoltage stall function, set F4-23 to 1: valid

FE-07	Short-to-ground protection option	Factory default	1	Attributes	<input type="radio"/>	
	Predetermined area	ones place	Power-on short-circuit protection selection			
		0	invalid			
		1	efficient			
		ten	Selection of short-circuit protection to ground before operation			
		0	invalid			
1	efficient					

Power-on short-circuit protection selection:

Every time the inverter is powered on, the inverter will detect whether the motor has a short circuit fault to ground.

Selection of short-circuit protection to ground before operation :

Before the inverter runs each time, first check whether the motor has a short-circuit fault to the ground, and if there is no such fault, it will start to run normally.

FE-08	Starting voltage of brake unit action	Factory default	Model confirmed	Attributes	<input type="radio"/>
	Predetermined area	380V model: 650.0V~800.0V; 220V model: 320.0V~800.0V			

The starting voltage  $V_{break}$  of the built-in braking unit action, the setting reference of this voltage value:  $(1.414V_s+30) \leq V_{break} \leq 800$

$V_s$  : Input the AC power voltage of the inverter

Note: Improper setting of this voltage may lead to abnormal operation of the built-in braking unit!

FE-09	Fault automatic reset times	Factory default	0	Attributes	<input type="radio"/>
	Predetermined area	0 ~ 30			
FE-10	During automatic fault reset Fault DO action selection	Factory default	1	Attributes	<input type="radio"/>
	Predetermined area	0	no action		
1		action			
FE-11	Fault automatic reset interval time	Factory default	6.0s	Attributes	<input type="radio"/>
	Predetermined area	0.1s ~ 100.0s			

Fault automatic reset times:

Set the number of times that can be automatically reset. After this number is exceeded, the inverter will no longer automatically reset the fault. Setting it to 0 means that the fault automatic reset function is not enabled.

Automatic reset DO action selection:

If the inverter has enabled the fault automatic reset function, this parameter can be used to set whether the fault DO relay will act during the fault reset period.

Auto reset interval:

After the inverter reports a fault, the fault automatically resets the waiting time.

FE-12	Input phase loss/ contactor pick-up protection selection		Factory default	11	Attributes	<input type="radio"/>
	Predetermined area	ones place	Input phase loss protection selection			
		0	Disable input phase loss protection			
		1	Simultaneous detection of software and hardware input phase loss condition protection			
		2	Software input phase loss protection			
		3	Hardware input phase loss protection			
		ten	Selection of contactor pull-in protection			
		0	prohibit			
		1	allow			

Input phase loss protection selection:

Input phase loss protection can choose hardware input phase loss protection and software input phase loss protection. When software protection is selected, the sensitivity of software input phase loss protection can be adjusted through parameters FE-74 and FE-75.

Selection of contactor pull-in protection:

This function is used to judge whether the starting resistor contactor is closed. If the starting resistor relay is not closed and the inverter is running with load, it will cause serious heating of the starting resistor or even burn the starting resistor. It is recommended that this feature remain enabled for protection selection.

FE-13	Output phase loss protection selection		Factory default	01	Attributes	<input type="radio"/>
	Predetermined area	ones place	Output phase loss protection selection			
		0	prohibit			
		1	allow			
		ten	Output phase loss protection selection before operation			
		0	prohibit			
1	allow					

Output phase loss protection selection:

protect the output phase loss. If you choose not to protect and the output phase loss fault actually occurs, the actual output current of the inverter will be distorted and even oscillated.

Output phase loss protection selection before operation:

If this function is turned on, the inverter will send out a DC signal to detect whether the output is out of phase before each operation.

FE-14	first failure type	Factory default	0	Attributes	●
	Predetermined area	0 ~ 99			
FE-15	Second failure type	Factory default	0	Attributes	●
	Predetermined area	0 ~ 99			
FE-16	Type of third failure	Factory default	0	Attributes	●
	Predetermined area	0 ~ 99			

The third failure is the latest failure, the second failure is the previous failure, and the first failure is the previous two failures. For the meaning of the fault code, the possible cause of the fault and the solution, please refer to the relevant part of the fault analysis.

Last fault status					
FE-17	Frequency at the third failure	Factory default	0	Attributes	●
	Predetermined area	0.00Hz ~ 655.35Hz			
FE-18	Current at the third fault	Factory default	0	Attributes	●
	Predetermined area	0.00A ~ 655.35A			
FE-19	Bus voltage at the third fault	Factory default	0	Attributes	●
	Predetermined area	0.0V ~ 6553.5V			
FE-20	Input terminal status at the third fault	Factory default	0	Attributes	●
	Predetermined area	0 ~ 9999			
FE-21	Output terminal status at the third fault	Factory default	0	Attributes	●
	Predetermined area	0 ~ 9999			
FE-22	Inverter status at the third fault	Factory default	0	Attributes	●
	Predetermined area	0 ~ 65535			
FE-23	Inverter power-on time when the third fault occurs	Factory default	0	Attributes	●
	Predetermined area	0s ~ 65535s			
FE-24	Inverter running time at the third fault	Factory default	0	Attributes	●
	Predetermined area	0.0s ~ 6553.5s			
previous failure status					
FE-27	Frequency at second failure	Factory default	0	Attributes	●
	Predetermined area	0.00Hz ~ 655.35Hz			
FE-28	Current at second fault	Factory default	0	Attributes	●
	Predetermined area	0.00A ~ 655.35A			



FE-29	Bus voltage at second fault	Factory default	0	Attributes	•
	Predetermined area	0.0V ~ 6553.5V			
FE-30	Input terminal status at the second fault	Factory default	0	Attributes	•
	Predetermined area	0 ~ 9999			
FE-31	Output terminal status at the second fault	Factory default	0	Attributes	•
	Predetermined area	0 ~ 9999			
FE-32	Inverter status at the time of the second fault	Factory default	0	Attributes	•
	Predetermined area	0 ~ 65535			
FE-33	Inverter power-on time when the second fault occurs	Factory default	0	Attributes	•
	Predetermined area	0s ~ 65535s			
FE-34	Inverter running time at ftanhwelt second	Factory default	0	Attributes	•
	Predetermined area	0.0s ~ 6553.5s			
<b>The previous two failure states</b>					
FE-37	Frequency at first failure	Factory default	0	Attributes	•
	Predetermined area	0.00Hz ~ 655.35Hz			
FE-38	Current at the first fault	Factory default	0	Attributes	•
	Predetermined area	0.00A ~ 655.35A			
FE-39	Bus voltage at first fault	Factory default	0	Attributes	•
	Predetermined area	0.0V ~ 6553.5V			
FE-40	Input terminal status at the first fault	Factory default	0	Attributes	•
	Predetermined area	0 ~ 9999			
FE-41	Output terminal status at the first fault	Factory default	0	Attributes	•
	Predetermined area	0 ~ 9999			
FE-42	Inverter status at the first fault	Factory default	0	Attributes	•
	Predetermined area	0 ~ 65535			
FE-43	Inverter power-on time when the first fault occurs	Factory default	0	Attributes	•
	Predetermined area	0s ~ 65535s			
FE-44	Inverter running time at the first fault	Factory default	0	Attributes	•
	Predetermined area	0.0s ~ 6553.5s			

Input terminal status at fault:

Display X state , converted into binary correspondence ( 1 means high level, 0 means low level )

Bit0 – X1 ; Bit1 – X2 ; Bit2 – X3 ; Bit3 – X4 ; Bit4 – HDI ;

Output terminal status at fault:

Display DO status , converted into binary correspondence ( 1 means high level, 0 means low level )

Bit0 – HDO ; Bit1 – Relay1 ; Bit2 – reserved ; Bit3 – Relay2 ; Bit4 – reserved;

Inverter status at fault:

Display the running status information of the inverter and convert it into a binary status corresponding table

Bit1 : Bit0 – 0 : Stop, 1 : Forward rotation; 2 : Reverse rotation

Bit3 : Bit2 – 0 : Constant speed, 1 : Acceleration; 2 : Deceleration

Bit4 – 0 : bus voltage is normal; 1 : undervoltage

Inverter power-on time at fault:

The power-on time of the fault (not the cumulative power-on time)

Inverter running time at fault:

The running time of the fault (not the accumulated running time)

FE-47	Failsafe action selection 1	Factory default	0	Attributes	<input type="radio"/>
		ones place	Motor overload		
		0	free parking		
		1	shutdown by shutdown		
		2	keep running		
		ten	Input phase loss (same as units )		
		hundreds	Output phase loss (same bit )		
FE-48	Failsafe action selection 2	Factory default	0	Attributes	<input type="radio"/>
		ones place	Encoder/ PG card abnormal		
		0	free parking		
		ten	Parameter read and write exception		
		0	free parking		
		1	shutdown by shutdown		
		hundreds	ID feedback value during operation (same as FE-47 one digit )		
FE-49	Failsafe Action Selection 3	Factory default	0	Attributes	<input type="radio"/>
		ones place	User-defined fault 1 (same as FE-47 digit )		
		ten	User-defined fault 2 (same as FE-47 digit )		
		hundreds	Power-on time arrival fault (same as FE-47 unit digit )		
		thousands	oad drop fault		
		0	free parking		
		1	Slow down and stop		
FE-49	Failsafe Action Selection 3	2	Jump directly to 7 % of the rated frequency of the motor to continue running, and automatically return to the set frequency when the load is not lost		
		ten thousand bits	ID feedback lost during operation (same as FE-47 ones )		

FE-50	Failsafe Action Selection 4		Factory default	0	Attributes	<input type="radio"/>
	Predetermined area	ones place	Excessive speed deviation (same as FE-47 unit )			
		ten	Motor overspeed (same as FE-47 unit )			
	hundreds	Initial position error (same as FE-47 digit )				

The above parameters are used to set the execution mode when the inverter has a corresponding fault.

When "free stop" is selected, the inverter will display E. xxx and stop directly.

When "Stop according to the stop mode" is selected: the inverter displays A. xxx , and stops according to the stop mode, and displays E.xxx after stop .

When "Continue to run" is selected: the inverter continues to run and displays A.xxx, and the running frequency is set by FE-54.

FE-54	Continue to run frequency selection in case of failure		Factory default	0	Attributes	<input type="radio"/>
	Predetermined area	0	run at current frequency			
		1	run at set frequency			
		2	run at upper frequency			
		3	run at lower frequency			
	4	Operates at abnormal standby frequency				
FE-55	Abnormal standby frequency		Factory default	100 . 0%	Attributes	<input type="radio"/>
	Predetermined area		0.0% ~ 100.0% ( 100.0% corresponds to the maximum frequency )			

When a fault occurs during the operation of the inverter, and the fault handling method is set to continue running, the inverter will display A.xxx and run at the frequency determined by FE-54.

When the abnormal standby frequency is selected to run, the value set by FE-55 is the percentage relative to the maximum frequency.

FE-56	Motor temperature sensor type		Factory default	0	Attributes	
	Predetermined area	0	no temperature sensor			
		1	PT100			
	2	PT1000				
FE-57	Motor overheat protection threshold		Factory default	110 °C	Attributes	<input type="radio"/>
	Predetermined area		0 °C ~ 200 °C			
FE-58	Motor overheating pre-alarm threshold		Factory default	90 °C	Attributes	<input type="radio"/>
	Predetermined area		0 °C ~ 200 °C			

If the motor temperature needs to be monitored, the temperature sensor needs to be connected to the analog input AI3 of the inverter expansion card . At present, two temperature sensors, PT100 and PT1000 , are supported , and FE-56 is set according to the type of connected sensor . The real-time temperature value of the motor can be viewed in U0-34 .

When the motor temperature exceeds the motor overheating protection threshold FE-57, the inverter reports E.OH2 fault .

When the motor temperature exceeds the motor overheating pre-alarm threshold FE-58, the multi-function digital DO or relay of the inverter outputs the motor over-temperature pre-alarm ON signal (DO or relay terminal function is set to 3

9 : motor over-temperature alarm) .

FE-59	Instantaneous stop non-stop function selection	Factory default	0	Attributes	<input type="radio"/>
	Predetermined area	0	invalid		
		1	Constant bus voltage control		
		2	Deceleration stop		
FE-60	Instantaneous power failure non-stop recovery voltage	Factory default	85%	Attributes	<input type="radio"/>
	Predetermined area	80% ~ 100%			
FE-61	Recovery voltage judgment time	Factory default	0.5s	Attributes	<input type="radio"/>
	Predetermined area	0.0s ~ 100.0s			
FE-62	Momentary stop non-stop judgment voltage	Factory default	80%	Attributes	<input type="radio"/>
	Predetermined area	60% ~ 100%			
FE-63	Instantaneous stop non-stop gain Kp	Factory default	40	Attributes	<input type="radio"/>
	Predetermined area	0 ~ 100			
FE-64	Instantaneous stop and non-stop integration Ki	Factory default	30	Attributes	<input type="radio"/>
	Predetermined area	0 ~ 100			
FE-65	Instantaneous stop non-stop deceleration time	Factory default	20.0s	Attributes	<input type="radio"/>
	Predetermined area	0.0s ~ 300.0s			

When the bus voltage drops below the "judgment voltage for instantaneous stop and non-stop action", the process of instantaneous stop and non-stop operation takes effect, and the output frequency of the inverter automatically drops to keep the motor in the state of power generation. Keep the bus voltage at about the "judgment voltage for instantaneous stop and non-stop action", and let the system decelerate to 0Hz normally. As shown below:

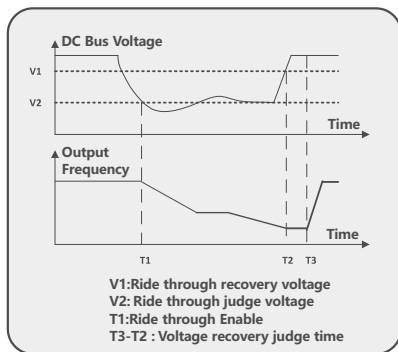

The purpose of non-stop instantaneous stop is to ensure that when the grid power supply is abnormal, the motor can decelerate and stop normally, so that the motor can start immediately after the grid restores normal power supply, and will not cause the motor to fail due to sudden undervoltage failure when the grid power supply is abnormal. Free stop ( in a large inertia system, it takes a long time for the motor to stop freely. When the grid power supply is normal, because the motor is still rotating at high speed, starting the motor at this time will easily cause the inverter to cause overload or overcurrent faults ) .

Bus voltage constant control :

When non-stop action occurs at a momentary stop, the inverter will adjust the output frequency through the PI loop to maintain the bus voltage at the "judgment voltage for non-stop action at a momentary stop" . When the grid power supply is restored, the output frequency of the inverter will continue to run to the target frequency.

Deceleration stop control:

When non-stop action occurs at a momentary stop, the inverter will adjust the output frequency through the PI loop to maintain the bus voltage at the "judgment voltage for non-stop action at a momentary stop" . When the grid power supply is restored, the frequency converter will continue to decelerate to 0Hz and stop until the frequency converter issues a start command again.

FE-66	Load Loss Protection Selection	Factory default	0	Attributes	○
	Predetermined area	0 invalid 1 efficient			
FE-67	Load drop detection level	Factory default	10.0%	Attributes	○
	Predetermined area	0.0 % ~ 100.0%			
FE-68	Load drop detection time	Factory default	1.0s	Attributes	○
	Predetermined area	0.0s ~ 60.0s			

If the load loss protection function is valid, when the output current of the inverter is lower than the load loss detection level FE-67, and the duration is longer than the load loss detection time FE-68, If you choose to continue running when the load is off, you can directly jump to 7% of the rated frequency of the motor to continue running. During the load loss protection period, if the load recovers, the inverter will automatically resume operation at the set frequency

FE-70	over speed detection value	Factory default	20.0%	Attributes	○
	Predetermined area	0.0 % ~ 50.0% ( maximum frequency )			
FE-71	over speed detection time	Factory default	1.0s	Attributes	○
	Predetermined area	0.0s ~ 60.0s			

This function is only valid when the inverter has speed sensor vector control.

When the inverter detects that the actual speed of the motor exceeds the maximum frequency, and the excess value is greater than the overspeed detection value FE-70, and the duration is longer than the overspeed detection time FE-71, the inverter will report a fault E.OS and act according to the fault protection way to deal with.

When the over-speed detection time is 0.0s, the over-speed fault detection is prohibited .

FE-72	Excessive speed deviation detection value	Factory default	20.0%	Attributes	○
	Predetermined area	0.0 % ~ 50.0% ( maximum frequency )			

FE-73	Excessive speed deviation detection time	Factory default	5.0s	Attributes	○
	Predetermined area	0.0s ~ 60.0s			

This function is only valid when the inverter has speed sensor vector control.

When the inverter detects that the actual speed of the motor deviates from the set frequency, and the deviation is greater than the excessive speed deviation detection value FE-72, and the duration is longer than the excessive speed deviation detection time FE-73, the inverter reports fault E.DEV, and handle it according to the fault protection action mode.

When the detection time of excessive speed deviation is 0.0s, the fault detection of excessive speed deviation is cancelled.

FE-74	Software input phase loss sensitivity	Factory default	5%	Attributes	○
	Predetermined area	1% ~ 50%			
FE-75	Software input phase loss filter	Factory default	20	Attributes	○
	Predetermined area	1 ~ 50			

When FE-12 input phase loss detection enables software input phase loss detection, the sensitivity of software input phase loss detection can be adjusted by modifying this parameter.

Input phase loss sensitivity:

The percentage setting of the sensitivity is based on the rated bus voltage of the inverter. Only when the fluctuation of the bus voltage is greater than the set value, the software input phase loss fault will be reported. Example: If the rated bus voltage is 540V , then the 5 % fluctuating voltage is 27V .

Input phase loss filter:

The filter parameters are used to eliminate software detection interference. The larger the parameter setting, the better the anti-interference performance, but the worse the software input phase loss detection sensitivity; the smaller the parameter setting, the worse the anti-interference performance, but the higher software input phase loss detection sensitivity , please set this parameter according to actual needs.

### 12.15 FF group user-defined function codes

FF-00 ~ FF-29	user function code	Factory default		Attributes	○
	Predetermined area	F0-00~FE-xx A0-00~A5-xx U0-00~U0-xx			

This group of function codes is user-defined parameter group. Among all the function codes, the user can select the required parameters and put them in the FF group as user-defined parameters . When switching to the user-defined parameter display mode through the QUICK button, you can quickly view the parameters set by the user .

The FF group provides up to 30 user-defined parameters, and the display value of the FF group parameter is F0.00, which means that the user function code is empty. When entering the user-defined parameter mode, the displayed function codes are defined by FF-00 ~ FF-31, and the sequence is consistent with the function codes of group FE, and skipped if it is F0-00.

### 12.16 A0 group terminal extension function

A0-00	AI curve 4 minimum input	Factory default	0.00V	Attributes	○
	Predetermined area	-10.00V ~ A0-02			
A0-01	AI curve 4 minimum input corresponding setting	Factory default	0.0%	Attributes	○
	Predetermined area	-100.0% ~ 100.0%			
A0-02	AI curve 4 inflection point 1 input	Factory default	0.00V	Attributes	○
	Predetermined area	A0-00~ A0-04			
A0-03	AI curve 4 inflection point 1 input corresponding setting	Factory default	30.0%	Attributes	○
	Predetermined area	-100.0% ~ 100.0%			
A0-04	AI curve 4 inflection point 2 input	Factory default	0.00V	Attributes	○
	Predetermined area	A0-02~ A0-06			
A0-05	AI curve 4 inflection point 2 input corresponding setting	Factory default	60.0%	Attributes	○
	Predetermined area	-100.0% ~ 100.0%			
A0-06	AI Curve 4 Maximum Input	Factory default	10.00V	Attributes	○
	Predetermined area	A0-04 ~ 10.00V			
A0-07	AI curve 4 maximum input corresponding setting	Factory default	100.0%	Attributes	○
	Predetermined area	-100.0% ~ 100.0%			

AI curve 4 can flexibly set the given setting corresponding to multi-point input voltage, as shown in the figure below:

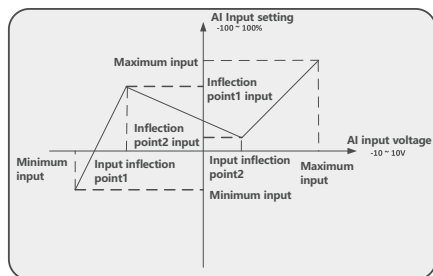

For the curve setting of AI5 , please refer to AI4 .

A0-24	AI1 set jump point	Factory default	0.0%	Attributes	<input type="radio"/>
	Predetermined area	-100.0% ~ 100.0%			
A0-25	AI1 sets the jump range	Factory default	0.1 %	Attributes	<input type="radio"/>
	Predetermined area	0.0% ~ 100.0%			
A0-26	AI2 set jump point	Factory default	0.0%	Attributes	<input type="radio"/>
	Predetermined area	-100.0% ~ 100.0%			
A0-27	AI2 set jump range	Factory default	0.1 %	Attributes	<input type="radio"/>
	Predetermined area	0.0% ~ 100.0%			
A0-28	AI3 set jump point	Factory default	0.0%	Attributes	<input type="radio"/>
	Predetermined area	-100.0% ~ 100.0%			
A0-29	AI3 set jump range	Factory default	0.1 %	Attributes	<input type="radio"/>
	Predetermined area	0.0% ~ 100.0%			

Analog input AI1~AI3 all have the setting value jump function. The skip function means that when the corresponding setting of the analog quantity changes within the range above and below the jump point, the corresponding set value of the analog quantity is fixed to the value of the jump point.

Example: The voltage of the analog input AI fluctuates around 5.00V, the fluctuation range is 4.90V~5.10V, the minimum input of AI1 0.00V corresponds to 0.0%, and the maximum input of 10.00V corresponds to 100.0%, then the detected AI1 should be set at Fluctuates between 49.0% and 51.0%.

Set AI1 to set the jump point A0-24 to 50.0%, set AI1 to set the jump range A0-25 to 1.0%, then when the above AI1 input is processed by the jump function, the corresponding setting of AI1 input is fixed at 50.0%. AI1 is turned into a stable input.

A0-30	Virtual VD1 terminal function	Factory default	0	Attributes	<input type="radio"/>
	Predetermined area	0 ~ 63			
A0-31	Virtual VD2 terminal function	Factory default	0	Attributes	<input type="radio"/>
	Predetermined area	0 ~ 63			
A0-32	Virtual VD3 terminal function	Factory default	0	Attributes	<input type="radio"/>
	Predetermined area	0 ~ 63			
A0-33	Virtual VD4 terminal function	Factory default	0	Attributes	<input type="radio"/>
	Predetermined area	0 ~ 63			



A0-34	Virtual VD5 terminal function	Factory default	0	Attributes	<input type="radio"/>
	Preetermined area	0 ~ 63			

The functions of virtual VDI1~VDI5 are exactly the same as X on the control board, and can be used as multi-function digital input. For detailed settings, please refer to the detailed explanation of digital multi-function input X function .

A0-35	VDI valid state setting	Factory default	0	Attributes	<input type="radio"/>	
	Preetermined area	ones place	VDI1			
		0	Whether the VDI is valid is determined by the state of the virtual VDOx			
		1	by parameter A0-36			
		ten	VDI2			
		hundreds	VDI3			
		thousands	VDI4			
ten thousand bits	VDI5					
A0-36	VDI terminal state setting	Factory default	0	Attributes	<input type="radio"/>	
	Preetermined area	ones place	VDI1			
		0	invalid			
		1	efficient			
		ten	VDI2			
		hundreds	VDI3			
		thousands	VDI4			
ten thousand bits	VDI5					

The state of the virtual VDI can be set in two ways, and can be selected through A0-35.

The VDI state is determined by the state of the corresponding virtual VDO :

VDIx The state is bound to the state of the VDOx . When VDOx acts, the corresponding VDI x is valid; when VDOx does not act, the corresponding VDI x is invalid.

For example: it needs to be set so that when the output current of the inverter reaches 120% of the rated current of the motor, the inverter will stop and report a fault, which can be set as follows

F8-38=120% ; F8-39=5% ; Arbitrary arrival current and detection range.

A0-30=44 user-defined fault 1.

A0-41=28 Virtual VDO1 output function selection <Current Reach 1 > .

At this time, run the inverter, when the output current reaches any current detection condition, the inverter will stop and report E.US1 user fault 1.

Set VDI state by parameter A0-36 :

X terminal can be changed by modifying the parameters manually or through communication .

For example: when setting A0-30=1 for forward running, A0-31=2 for reverse running. At this time, the A0-36 ones and tens data can be modified manually or by communication to control the forward and reverse operation of the inverter.

A0-37	Function selection when AI1 is used as X	Factory default	0	Attributes	<input type="radio"/>
	Preetermined area	0 ~ 63			

A0-38	Function selection when AI2 is used as X	Factory default	0	Attributes	<input type="radio"/>
	Predetermined area	0 ~ 63			
A0-39	Function selection when AI3 is used as X	Factory default	0	Attributes	<input type="radio"/>
	Predetermined area	0 ~ 63			
A0-40	AI is used as X effective mode selection	Factory default	0	Attributes	<input type="radio"/>
	Predetermined area	ones place	AI1		
		0	active high		
		1	active low		
		ten	AI2		
hundreds	AI3				

This group of function codes is used to use AI as X. When AI is used as X, when the AI input voltage is greater than 7V, the AI terminal state is high level, and when the AI input voltage is lower than 3V, the AI terminal state is low level. The state remains unchanged between 3V~7V.

A0-40 is used to determine when AI is used as X, whether the high level of AI is valid or the low level is valid.

A0-41	VDO1 output function selection	Factory default	0	Attributes	<input type="radio"/>
	Predetermined area	0	Internally shorted to physical Xx		
1 ~ 41		Same function as DO output			
A0-46	VDO1 output delay time	Factory default	0.0s	Attributes	<input type="radio"/>
	Predetermined area	0.0s ~ 3600.0s			
A0-51	VDO output valid state	Factory default	0	Attributes	<input type="radio"/>
	Predetermined area	ones place	VDO1		
		0	positive logic		
		1	counter logic		
		ten	VDO2		
		hundreds	VDO3		
		thousands	VDO4		
ten thousand bits	VDO5				

This group of parameters is used to set the function of virtual VDO output.

The function selections of VDOx have two ways:

Internally shorted to physical Xx:

The state at this time is determined by the external terminal Xx of the inverter. When Xx input is valid, VDO x outputs an active state; when Xx input is invalid, VDOx outputs an invalid state.

Same functions as DO output:

At this time, for VDO function, please refer to F6 group multi-function digital output DO function.

At the same time, the effective output state of VDOx can be selected as positive logic or negative logic.

### 12.17 A5 group second motor parameters

The function code of group A5 corresponds to motor 2. The definition and use of all parameters in group A5 are consistent with those of the first motor. Please refer to the detailed explanation of the relevant parameters of groups F2 and F3 of the first motor.

A5-00	motor type	Factory default	0	Attributes	<input type="radio"/>
	Predetermined area	0	Ordinary asynchronous motor		
		1	Inverter asynchronous motor		
A5-01	Motor rated power	Factory default	Model confirmed	Attributes	<input type="radio"/>
	Predetermined area	0.1kW~1000.0kW			
A5-02	Motor rated voltage	Factory default	Model confirmed	Attributes	<input type="radio"/>
	Predetermined area	1V ~ 2000V			
A5-03	Motor rated current	Factory default	Model confirmed	Attributes	<input type="radio"/>
	Predetermined area	0.01A~655.35A (inverter power ≤ 55kW) 0.1A~6553.5A (inverter power>55kW)			
A5-04	Motor rated frequency	Factory default	Model confirmed	Attributes	<input type="radio"/>
	Predetermined area	0.01Hz ~ maximum frequency			
A5-05	Motor rated speed	Factory default	Model confirmed	Attributes	<input type="radio"/>
	Predetermined area	1rpm ~ 65535rpm			
A5-06	Asynchronous motor stator resistance	Factory default	Tuning parameters	Attributes	<input type="radio"/>
	Predetermined area	0.001Ω~65.535Ω (inverter power ≤ 55kW) 0.0001Ω~6.5535Ω (inverter power>55kW)			
A5-07	Asynchronous motor rotor resistance	Factory default	Tuning parameters	Attributes	<input type="radio"/>
	Predetermined area	0.001Ω~65.535Ω (inverter power ≤ 55kW) 0.0001Ω~6.5535Ω (inverter power>55kW)			
A5-08	Asynchronous motor leakage inductance	Factory default	Tuning parameters	Attributes	<input type="radio"/>
	Predetermined area	0.01mH~ 655.35mH (inverter power ≤ 55kW) 0.001mH~65.535mH (inverter power>55kW)			
A5-09	Mutual inductance reactance of asynchronous motor	Factory default	Tuning parameters	Attributes	<input type="radio"/>
	Predetermined area	0.001mH~65.535mH (inverter power ≤ 55kW) 0.01mH~655.35mH (inverter power>55kW)			
A5-10	Asynchronous motor no-load current	Factory default	Tuning parameters	Attributes	<input type="radio"/>
	Predetermined area	0.01A~A5-03 (inverter power ≤ 55kW) 0.1A~A5-03 (inverter power>55kW)			
A5-27	Encoder lines	Factory default	1024	Attributes	<input type="radio"/>
	Predetermined area	1 ~ 65535			

A5-28	encoder type	Factory default	0	Attributes	<input type="radio"/>	
	Predetermined area	0	ABZ incremental encoder			
		2	Resolver			
A5-30	ABZ incremental encoder AB phase sequence	Factory default	0	Attributes	<input type="radio"/>	
	Predetermined area	0	Forward			
		1	reverse			
A5-34	Resolver pole pairs	Factory default	1	Attributes	<input type="radio"/>	
	Predetermined area	1 ~ 65535				
A5-36	P G disconnection detection time	Factory default	0.0s	Attributes	<input type="radio"/>	
	Predetermined area	0.0s ~ 10.0s				
A5-37	tuning selection	Factory default	0	Attributes	<input type="radio"/>	
	Predetermined area	0	no action			
		1	Parameter Tuning of Static Part of Asynchronous Machine			
		2	Dynamic complete tuning of asynchronous machines			
	3	Asynchronous machine static complete tuning				
A5-38	Speed loop proportional gain 1	Factory default	30	Attributes	<input type="radio"/>	
	Predetermined area	1 ~ 100				
A5-39	Speed loop integration time 1	Factory default	0.50s	Attributes	<input type="radio"/>	
	Predetermined area	0.01s ~ 10.00s				
A5-40	Switching frequency 1	Factory default	5.00Hz	Attributes	<input type="radio"/>	
	Predetermined area	0.00 ~ A5-43				
A5-41	Speed loop proportional gain 2	Factory default	20	Attributes	<input type="radio"/>	
	Predetermined area	1 ~ 100				
A5-42	Speed loop integration time 2	Factory default	1.00s	Attributes	<input type="radio"/>	
	Predetermined area	0.01s ~ 10.00s				
A5-43	Switching frequency 2	Factory default	10.00Hz	Attributes	<input type="radio"/>	
	Predetermined area	A5-40 ~ maximum frequency				
A5-44	Vector control slip gain	Factory default	100%	Attributes	<input type="radio"/>	
	Predetermined area	50% ~ 200%				
A5-45	SVC speed feedback filter time	Factory default	0.050s	Attributes	<input type="radio"/>	
	Predetermined area	0.000s ~ 1.000s				

A5-47	Speed control torque upper limit source		Factory default	0	Attributes	<input type="radio"/>
	Predetermined area	0	A5-48 setting			
		1	AI1			
		2	AI2			
		3	AI3			
		4	HDI			
		5	communication settings			
		6	MIN (AI1,AI2)			
7	MAX (AI1,AI2)					
A5-48	Torque upper limit digital setting		Factory default	150.0%	Attributes	<input type="radio"/>
	Predetermined area		0.0% ~ 200.0%			
A5-49	Speed control torque upper limit source (power generation)		Factory default	0	Attributes	<input checked="" type="radio"/>
	Predetermined area	0	A5-47 settings (no distinction between electric and power generation)			
		1	AI1			
		2	AI2			
		3	AI3			
		4	HDI			
		5	communication settings			
		6	MIN (AI1,AI2)			
		7	MAX (AI1,AI2)			
8	Parameter A5-50 setting					
A5-50	Torque upper limit digital setting (power generation)		Factory default	150.0%	Attributes	<input type="radio"/>
	Predetermined area		0.0% ~ 200.0%			
A5-51	Excitation regulation proportional gain		Factory default	2000	Attributes	<input type="radio"/>
	Predetermined area		0 ~ 60000			
A5-52	Excitation regulation integral gain		Factory default	1300	Attributes	<input type="radio"/>
	Predetermined area		0 ~ 60000			
A5-53	Torque regulation proportional gain		Factory default	2000	Attributes	<input type="radio"/>
	Predetermined area		0 ~ 60000			
A5-54	Torque adjustment integral gain		Factory default	1300	Attributes	<input type="radio"/>
	Predetermined area		0 ~ 60000			
A5-60	Generation power limit enable		Factory default	0	Attributes	<input checked="" type="radio"/>
	Predetermined area	0	invalid			
		1	take effect			

A5-61	Generating power upper limit	Factory default	Model confirmed	Attributes	<input type="radio"/>
	Predetermined area	0.0% ~ 200.0%			
A5-62	control method	Factory default	2	Attributes	<input checked="" type="radio"/>
	Predetermined area	0	Speed sensorless vector control (SVC)		
		1	Vector control with speed sensor (FVC)		
		2	V/F control		
A5-63	Motor 2 acceleration and deceleration time selection	Factory default	0	Attributes	<input type="radio"/>
	Predetermined area	0	Same as the 1st motor		
		1	Acceleration and deceleration time 1		
		2	Acceleration and deceleration time 2		
		3	Acceleration and deceleration time 3		
4	Acceleration and deceleration time 4				
A5-64	Motor 2 torque boost	Factory default	Model confirmed	Attributes	<input type="radio"/>
	Predetermined area	0.0 % : Automatic torque boost 0.1 % ~ 30.0%			
A5-66	Motor 2 Oscillation Suppression Gain	Factory default	Model confirmed	Attributes	<input type="radio"/>
	Predetermined area	0 ~ 100			

### 12.18 U0 group monitoring parameters

The U0 parameter group is used to monitor the operation status information of the inverter, and the customer can view it through the panel to facilitate on-site debugging. The parameters in this group are read-only parameters and cannot be modified.

Parameter number	Function	Parameter range	Illustrate
U0-00	operating frequency	0.00 ~ 500.00Hz	Display the current inverter running frequency
U0-01	set frequency	0.00 ~ 500.00Hz	Display the inverter target frequency
U0-02	bus voltage	0.0V ~ 3000.0V	Display the inverter bus voltage value
U0-03	The output voltage	0V ~ 1140V	Display the inverter output voltage value during operation
U0-04	Output current	0.00A ~ 655.35A (Inverter power ≤ 55KW) 0.0A ~ 6553.5A (Inverter power > 55KW)	Display the inverter output current value during operation
U0-05	Output Power	0.0KW ~ 6553.5KW	Display the inverter output power (active power) during operation
U0-06	output torque	-200.0% ~ 200.0%	Displays the percentage output value of the rated motor torque

0-07	X input state	0 ~ 32767	Display X state , converted into binary correspondence ( 1 means high level, 0 means low level )Bit0-X1 ; Bit1-X2 ; Bit2-X3 ; Bit3-X4 ; Bit4-HDI ;
U0-08	DO output state	0 ~ 32767	Display DO status , converted into binary correspondence ( 1 means high level, 0 means low level ) Bit0-HDO ; Bit1-Relay1 ; Bit2-reserved; Bit3-Relay2 ; Bit4-Reserved;
U0-09	AI1 voltage	0.00V ~ 11.00V	Corrected voltage
U0-10	AI2 voltage	0.00V ~ 11.00V	Corrected voltage
U0-11	AI3 voltage	0.00V ~ 11.00V	Corrected voltage
U0-12	count value	0 ~ 65535	the pulse signal count value when X is set as <counter input > function
U0-13	length value	0 ~ 65535m	the record length value when X is set as <length count input > function
U0-14	load speed	0 ~ 65535	Stop: set frequency * coefficient ( F7-07 );run: running frequency * coefficient ( F7-07)
U0-15	PID setting	0 ~ 65535	Set value (percentage ) * range ( F9-04)
U0-16	PID feedback	0 ~ 65535	Feedback value (percentage ) * range ( F9-04)
U0-17	PLC stage	0 ~ 15	current PLC function is running
U0-18	Input pulse frequency	0.00kH~100.00KHz	Displays the high-speed pulse frequency input from the HDI terminal
U0-19	Feedback speed	-320.00Hz~320.00Hz	The actual operating frequency of the motor, V/F is the output frequency of the inverter, and the decimal point is set by F7-08
U0-20	remaining run time	0.0 ~ 6500.0min	the timing function is enabled ( F8-42) , it displays the remaining running time of the inverter
U0-21	AI1 voltage before correction	0.00V ~ 11.0V	Voltage before correction
U0-22	AI2 voltage before correction	0.00V ~ 11.0V	Voltage before correction
U0-23	AI3 voltage before correction	0.00V ~ 11.0V	Voltage before correction
U0-24	Motor speed	0 ~ 65535m/min	Display the line speed of HDI sampling, and calculate the line speed value according to the actual number of pulses sampled per minute and F9-36 ( number of pulses per meter)
U0-25	Current power-on time	0 ~ 65535min	Reset when power off
U0-26	current running time	0 ~ 65535min	Shutdown reset
U0-27	Input pulse frequency	0 ~ 65535Hz	as U0-18 , in Hz
U0-28	Communication settings	-100.00% ~ 100.00%	Communication settings set frequency, set torque, etc

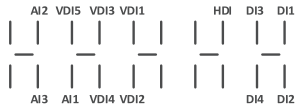
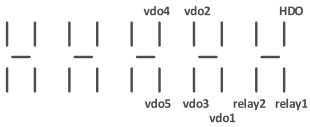
U0-29	Encoder feedback speed	-320.00Hz~320.00Hz	The running frequency of the motor actually measured by the encoder, the displayed decimal point is set by F7-08
U0-30	main frequency display	0.00 ~ 500.00Hz	Display main frequency given
U0-31	Auxiliary frequency display	0.00 ~ 500.00Hz	Display main and auxiliary frequency given
U0-32	reserve		
U0-33	reserve		
U0-34	Motor temperature value	0°C~200°C	When AI3 is connected to the motor temperature sensor, it will display the motor temperature
U0-35	target torque	-200.0% ~ 200.0%	Display the current torque target setting value
U0-36	Resolver position	0 ~ 4096	Display the current position signal of the resolver
U0-37	Power Factor Angle	-180°~180°	Displays the power factor angle of the output power
U0-38	ABZ position	0 ~ 65535	Display the current AB phase pulse count of ABZ or UVW encoder , which is the number of pulses after 4 frequency multiplication . When the encoder rotates forward, the value increases automatically, when the encoder reverses, the value decreases automatically, when it increases to 65535, it restarts counting from 0, and when it decreases to 0, it restarts counting from 65535
U0-39	V/F separation target voltage	0V~motor rated voltage	Display the target output voltage when running in V/F separation state
U0-40	V/F separation output voltage	0V~motor rated voltage	Display the current actual output voltage when running in V/F separation state
U0-41	Visual display of X input status		 <p>The segment code display of the digital tube is bright for high level and off for low level</p>
U0-42	Visual display of DO output status		 <p>The segment code display of the digital tube is bright for high level and off for low level</p>

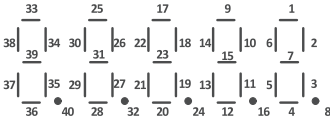
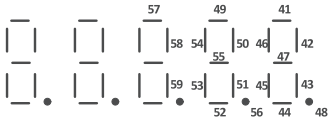

U0-43	Visual display of X function status 1		 <p>The segment code display of the digital tube is on for the corresponding function is valid, and off is for the corresponding function is invalid</p>
U0-44	Visual display of X function status 2		 <p>The segment code display of the digital tube is on for the corresponding function is valid, and off is for the corresponding function is invalid</p>
U0-45~ U0-57	reserve		
U0-58	Z signal counter	0 ~ 65535	Display the current Z phase pulse count of ABZ or UVW encoder . Each time the encoder rotates forward or reverses, the corresponding value is increased or decreased by 1. Checking this value can detect whether the encoder is installed normally.
U0-59	reserve		
U0-60	reserve		
U0-61	Inverter status	0 ~ 65535	Display the running status information of the inverter and convert it into a binary status corresponding table Bit1 : Bit0-0 : Stop, 1 : Forward rotation; 2 : Reverse rotation Bit3 : Bit2-0 : Constant speed, 1 : Acceleration; 2 : Deceleration Bit4-0 : bus voltage is normal; 1 : undervoltage
U0-62	current fault code	0 ~ 99	Display the current fault code, please refer to the fault table for details
U0-63	reserve		
U0-64	reserve		
U0-65	Torque upper limit	-200.0% ~ 200.0%	The percentage shows the upper limit of the current given torque
U0-66~ U0-72	reserve		
U0-73	motor selection	0 ~ 1	0: Motor 1 1: Motor 2
U0-74	reserve		
U0-75	inverter module	-20 °C ~ 150 °C	radiator temperature
U0-76	Product ID	600	Inverter model serial number
U0-77	Cumulative running time	0 ~ 65535h	

U0-78	Performance version number		
U0-79	feature version number		
U0-80	Cumulative power-on time	0~65535 hours	
U0-81	cumulative power consumption	0~65535 degrees	
U0-82	Cumulative low power consumption	0~999.9 degrees	
U0-83	Cumulative high power consumption	0~65535 degrees	
U0-84	Inverter rated capacity		0.0KW ~ 6553.5KW
U0-85	Inverter rated current	0.00A~655.35A (Inverter power < 55KW) 0.0A~6553.5A (Inverter power > 55KW)	

## 12.19 Modbus communication

### 1) Networking method

The inverter provides RS485 communication interface, and adopts the international standard Modbus communication protocol for master-slave communication. Users can realize centralized control through PC/PLC , host computer monitoring software, etc. (setting inverter control commands, operating frequency, modification of relevant function code parameters, monitoring of inverter working status and fault information, etc.), to adapt to specific application requirements.

There are two networking modes of the inverter (as a slave station): single-master / multi-slave mode, single-master / single-slave mode, as shown in the figure below:

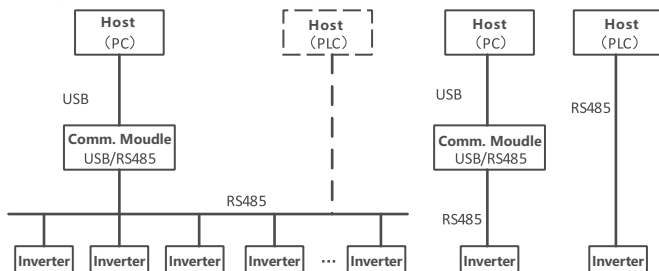

Modbus communication related parameters can refer to Fb group function code description, the default communication parameters are as follows :

Slave address: 0x01

Baud rate: 9600bps

Data format: 8-N-2 ( 8 data bits, no parity, 2 stop bits)

## 2) Wiring instructions

### 2. 1) Topology

No repeater RS-485-Modbus has a trunk cable to which all devices are connected directly or via short breakout cables.

The trunk cable, also known as the bus, can be very long. It must be terminated at both ends. It is also possible to use a repeater between multiple RS-485 Modbus . And the address of each slave address in the network is unique, which is the basis for ensuring Modbus serial communication.

### 2.2 ) Length

The end-to-end length of trunk cables must be limited. The maximum length is related to baud rate, cable (gauge, capacitance or characteristic impedance), number of loads on the daisy chain, and network configuration ( 2-wire or 4-wire).

For cables with a high-speed baud rate of 9600bps and AWG26 (or thicker) specifications, the maximum length is 1000m .

Branches must be short and cannot exceed 20m . If a multi-port splitter with n branches is used, the maximum length of each branch must be limited to 40m divided by n .

### 2.3) Grounding form

" common " circuit (signal and optional power common) must be connected directly to protective ground, preferably at a single point along the entire bus. Typically, this point can be selected on the master or its taps.

### 2.4) cable

Modbus cable on the serial link must be shielded. At one end of each cable, its shield must be connected to protective earth. If a connector is used at this end, connect the connector housing to the cable shield. RS485-Modbus must use a balanced pair and a third wire (for common).

For RS485-Modbus , the cable diameter must be chosen wide enough to allow the use of the maximum length ( 1000m ). AWG24 can meet the needs of Modbus data transmission.

## 3) communication method

1) The communication protocol of the inverter is Modbus protocol, which supports RTU protocol.

2) The frequency converter is a slave machine, master-slave point-to-point communication. When the master uses the broadcast address to send commands, the slave does not respond.

3) In the case of multi-machine communication or long-distance, parallel connection of (100-120 ) ohm resistance at the positive end and negative end of the signal line of the master station communication can improve the immunity of communication.

4) The inverter provides an interface of RS485 , if the communication port of the external device is RS232 , an additional RS232/RS485 conversion device is required.

## 4) Protocol format

The Modbus protocol supports RTU mode, and the corresponding frame format is shown in the figure below

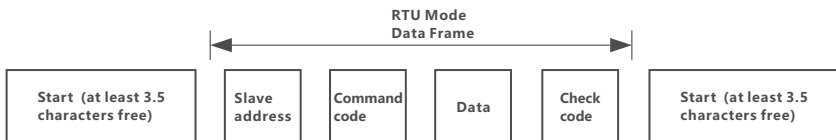

In RTU mode, the idle time between frames takes the larger value between the function code setting and the Modbus internal agreed value. The minimum inter-frame idle time agreed within Modbus is as follows: the frame header and frame tail define the frame through the bus idle time not less than 3.5 bytes. It is enough to keep the bus idle of at least 3.5 characters between frames, and the bus idle between frames does not need to accumulate the start and end idle.

Slave station address: the setting range of inverter slave station address is 1 ~247 . When the address sent by the master station is 0, it is a broadcast address, and the slave station does not need to recover. Broadcast commands can only be used for write commands.

Function code: currently the inverter supports the following three Modbus function codes

Function code	Illustrate
0x 03	read register instruction
0x 06	write single register instruction
0x 10	write multiple registers instruction

Data: Modbus registers are 2 bytes in length, so the register data written by the inverter is usually 2 bytes, and the register data read from the inverter is also composed of 2 bytes. The inverter can read or read at most at one time. Write 12 register data.

Check code: CRC-16 is used for data check , and the whole frame information participates in the check, and the check data is first sent the low byte and then the high byte.

Communication example:

Communication 0x03 function code read F0-08 data

Master → Inverter		Master ← Inverter	
slave address	0x01	slave address	0x01
function code	0x03	function code	0x03
register high byte	0x00	Number of registers	0x02
register low byte	0x08	data high byte	0x13
Register number high byte	0x00	data low byte	0x88
Low byte of the number of registers	0x01	CRC low byte	0xB5
CRC low byte	0x05	CRC high byte	0x12
CRC high byte	0xC8		

Communication 0x06 function code modify F0-08 parameter to 40.00Hz

Master → Inverter		Master ← Inverter	
slave address	0x01	slave address	0x01
function code	0x06	function code	0x06
register high byte	0x00	register high byte	0x00
register low byte	0x08	register low byte	0x08
data high byte	0x0F	data high byte	0x0F
data low byte	0xA0	data low byte	0xA0
CRC low byte	0x0D	CRC low byte	0x0D
CRC high byte	0x80	CRC high byte	0x80

Communication 0x10 function code modify the two parameters of F0-17 and F0-18 to 10.0s

Master → Inverter		Master ← Inverter	
slave address	0x01	slave address	0x01
function code	0x10	function code	0x10
start register high byte	0x00	start register high byte	0x00
Start Register Low Byte	0x11	Start Register Low Byte	0x11
Register number high byte	0x00	Register number high byte	0x00
Low byte of the number of registers	0x02	Low byte of the number of registers	0x02
register bytes	0x04	CRC low byte	0x11
Data 1 high byte	0x00	CRC high byte	0xCD
Data 1 low byte	0x64		
Data 2 high byte	0x00		
Data 2 low byte	0x64		
CRC low byte	0x73		
CRC high byte	0x5B		

Communication failure frame return data:

Fault frame (master station ← inverter )	
slave address	
0x80 + function code	
Fault codes (defined in the table below )	
CRC low byte	
CRC high byte	

Communication fault code definition:

Serial number	Communication fault code	Fault description
1	0x01	illegal order
2	0x02	illegal address
3	0x03	illegal data
4	0x04	Other errors(CRC error, parameter read-only, parameter locked, etc.)

a) Function code parameter address rule

Use the function code group number and label as the parameter address to express the rules:

High byte: 0x00~0x0F (F0~FF group), 0x40~0x45 (A0~A5 group), 0x70 (U0 group)

Low byte: 0x00~0xFF

For example: if you want to access the function code F0-08, the access address of the function code is expressed as 0x0008;

Notice:

Group U: It is a read-only parameter and cannot be modified.

Some parameters cannot be changed when the inverter is running; some parameters cannot be changed regardless of the state of the inverter; when changing function code parameters, pay attention to the parameter range, unit, and related instructions.

Function code group number	Newsletter access address	Newsletter modification RAM_Medium function code address
F0~FF Group	0x0000 ~ 0x0FFF	0x8000 ~ 0x8FFF
A0~A5 groups	0x4000 ~ 0x45FF	0xC000 ~ 0xC5FF
U0 group	0x7000 ~ 0x70FF	

Because EEPROM is frequently stored, it will reduce the service life of EEPROM, so some function codes do not need to be stored in the communication mode, just change the value in RAM. When the data only needs to be saved in the RAM (that is, the data is not saved after power failure), set the highest position of the address to "1".

example:

The function code F0-08 is not stored in EEPROM, and the address is expressed as 8008;

This address indicates that it can only be used for writing to RAM, and cannot be used for reading. When reading, it is an invalid address.

Communication settings: (write only)

Communication setting address	Settings
3201H	-10000 ~ 10000

The communication setting value is the percentage of the relative value, 10000 corresponds to 100.00%, and -10000 corresponds to -100.00%. For the data of frequency dimension, this percentage is the percentage of relative maximum frequency (F0-10); for the data of torque dimension, this percentage is F3-11.

Note: The "communication setting" option that appears in the parameter is set data through this address.

Control command: (write only)

Order	Address	Command function
Control commands	3200H	000 0 : no command
		000 1 : Forward running
		000 2 : reverse operation
		000 3 : Deceleration to stop
		000 4 : forward jog
		000 5 : reverse jog
		000 6 : Reserved
		000 7 : Free stop
		000 8 : fault reset
Digital output control	3202H	BIT0: DO1 output control
		BIT1: DO2 output control
		BIT2: RELAY1 output control
		BIT3: RELAY2 output control
		BIT4: HDO output control
		BIT5: VDO1
		BIT6: VDO2
		BIT7: VDO3
		BIT8: VDO4
		BIT9: VDO5
AO1 control	3203H	0 ~ 7FFF means 0% ~ 100%
AO2 control	3204H	0 ~ 7FFF means 0% ~ 100%
Pulse control	3205H	0 ~ 7FFF means 0% ~ 100%

Read inverter status: (read only)

State address	Status word
3300H	Bit0 : run / stop ( 0 , stop; 1 , run )
	Bit1 : forward / reverse ( 0 , forward; 1 , reverse )
	Bit2 : Running at zero speed (1 is valid )
	Bit3 : Acceleration running (1 is valid )
	Bit4 : Deceleration running (1 is valid )
	Bit5 : Running at constant speed (1 is valid )
	Bit6 : Reserved
	Bit7 : Reserved
	Bit8 : Reserved
	Bit9 : Reserved
	Bit10 : Reserved
	Bit11 : Reserved
	Bit12 : Inverter fault (1 fault )
	Bit13 : Operation preparation completed (1 preparation completed )
	Bit14 : Reserved
Bit15 : Reserved	

Shutdown/Run Parameters section:

Parameter address	Parameter Description	Parameter address	Parameter Description
3400H	Output frequency	3411H	PLC steps
3401H	set frequency	3412H	Count value input
3402H	bus voltage	3413H	Length value input
3403H	The output voltage	3414H	Feedback speed, unit 0.1Hz
3404H	Output current	3415H	Line speed
3405H	running speed	3416H	AI1 voltage before correction
3406H	Output Power	3417H	AI2 voltage before correction
3407H	output torque	3418H	AI3 voltage before correction
3408H	PID settings	3419H	remaining run time
3409H	PID feedback	341AH	Current power-on time
340AH	X input flag	341BH	current running time
340BH	DO output flag	341CH	PULSE input pulse frequency, unit 1Hz
340CH	Target torque (%)	341DH	load speed
340DH	AI1 voltage	341EH	actual feedback speed
340EH	AI2 voltage	341FH	main frequency X display
340FH	AI3 voltage	3420H	Auxiliary frequency Y display
3410H	PULSE input pulse frequency, Unit 0.01kHz		

F0-28 parameter initialization communication:

In order to prevent misoperation, before modifying F0-28 in communication operation, user password F7-00 must be operated by communication first, and F0-28 can only be operated after writing data into F7-00. Even if no user password is set, it is necessary to write 0 to F7-00. For example, you need to reset the parameters

Send data: 01 06 07 00 00 00 88 BE

Return data: 01 06 07 00 88 88 EE D8

write again

Send data: 01 06 00 1C 00 02 C9 CD

Return data: 01 06 00 1C 00 02 C9 CD

User-defined parameter group FF group communication:

1. When the communication needs to modify the parameter address mapped by the user-defined parameter group FF-XX, the operating register address is 0x2FXX. For example, if it is necessary to modify the F0-08 parameter mapped to FF-00, send the following command:

Send data: 01 06 2F 00 F0 08 C4 D8

Return data: 01 06 2F 00 F0 08 C4 D8

Different parameter groups map different data, as shown in the following table

parameter group	map communication data
F0~FE group	0xF0XX
A0 group	0xA0XX
Group U	0x70XX

2. When the register address of the communication operation is FF-XX, the communication operation is the parameter mapped in the FF group, for example, the setting in FF-00 is F0-08, when writing 0F-00 through the 06 function code. When addressing, modify the parameters of F0.08

Send data: 01 06 0F 00 03 E8 8A 60

Return data: 01 06 0F 00 03 E8 8A 60

At this time, the preset frequency of F0-08 is modified by 10.00Hz.



### 13 General table of parameters

\*○\*: Indicates that the setting value of this parameter can be changed when the inverter is in stop or running state;

\*◎\*: Indicates that the set value of this parameter cannot be changed when the inverter is running;

●\*: Indicates that the value of this parameter is the actual detection record value and cannot be changed;

Parameter	Name	Predetermined area	Factory default	Change
<b>F0 group basic functions</b>				
F0-00	TP type setting	1 : T type (constant torque load type) 2 : P type (fan, water pump load type)	1	◎
F0-01	1st motor control method	0 : Sensorless vector control ( SVC ) 1 : With speed sensor vector control( FVC ) 2 : V/F control	2	◎
F0-02	Run command selection	0 : Operation panel 1 : terminal 2 : Communication	0	○
F0-03	Main frequency command input selection	0 : digital setting (no memory when power off) 1 : Digital setting (power-down memory) 2 : AI1 3 : AI2 4 : AI3 5 : Pulse setting ( HDI ) 6 : Multi-segment instruction 7 : Simple PLC 8 : PID 9 : Communication setting	0	◎
F0-04	Auxiliary frequency command input selection	Same as F0-03 ( main frequency command input selection )	0	◎
F0-05	Auxiliary frequency command range selection during superimposition	0 : relative to the maximum frequency 1 : Relative to the main frequency command	0	○
F0-06	Auxiliary frequency command range during superimposition	0%~150%	100%	○
F0-07	Frequency command superposition selection	Units: frequency command selection 0 : main frequency command 1 : main and auxiliary operation results (the operation relationship is determined by tens) 2 : switch between main frequency command and auxiliary frequency command 3 : switch between the main frequency command and the main and auxiliary calculation results	00	○

F0-07	Frequency command superposition selection	4 : Switch between auxiliary frequency command and main and auxiliary calculation results Tens place: main and auxiliary operation relationship of frequency command 0 : main + auxiliary 1 : main - auxiliary 2 : the maximum value of both 3 : the minimum of both	00	○
F0-08	preset frequency	0.00Hz~ maximum frequency( F0-10 )	50.00Hz	○
F0-09	Running direction	0 : run in the default direction 1 : run in the opposite direction from the default direction	0	○
F0-10	maximum frequency	50.00Hz~500.00Hz	50.00Hz	⊙
F0-11	Upper limit frequency command selection	0 : F0-12 setting 1 : AI1 2 : AI2 3 : AI3 4 : Pulse setting 5 : Communication setting	0	⊙
F0-12	upper limit frequency	Lower limit frequency F0-14~ maximum frequency F0-10	50.00Hz	○
F0-13	Upper limit frequency offset	0.00Hz~ maximum frequency F0-10	0.00Hz	○
F0-14	lower limit frequency	0.00Hz~ upper limit frequency F0-12	0.00Hz	○
F0-15	carrier frequency	Model confirmed	Model confirmed	○
F0-16	Carrier frequency adjusted with temperature	0 : no 1 : yes	1	○
F0-17	Acceleration time 1	0.00s~650.00s(F0-19=2) 0.0s~6500.0s(F0-19=1) 0s~65000s(F0-19=0)	Model confirmed	○
F0-18	Deceleration time 1	0.00s~650.00s(F0-19=2) 0.0s~6500.0s(F0-19=1) 0s~65000s(F0-19=0)	Model confirmed	○
F0-19	Acceleration and deceleration time unit	0 : 1 sec 1 : 0.1 sec 2 : 0.01 sec	1	⊙
F0-20	Digital setting frequency stop memory selection	0 : no memory 1 : memory	0	○
F0-21	Acceleration and deceleration time base frequency	0 : maximum frequency ( F0-10) 1 : set frequency 2 : 100Hz	0	⊙
F0-22	UP/DOWN reference during operation	0 : Running frequency 1 : Setting frequency	0	⊙

F0-23	Running command bundled main frequency command selection select	Units: operation panel binding frequency source selection 0 : no binding 1 : Digital setting frequency 2 : AI1 3 : AI2 4 : AI3 5 : Pulse setting ( HDI ) 6 : Multi-stage speed 7 : Simple PLC 8 : PID 9 : Communication setting Tens digit: terminal binding frequency source selection Hundreds place: communication binding frequency source selection	000	○
F0-24	reserve			
F0-25	reserve			
F0-26	reserve			
F0-27	Motor parameter group selection	0: Motor parameter group 1 1 : Motor parameter group 2	0	○
F0-28	parameter initialization	0 : no operation 01 : Clear record information 02 : Restore factory parameters, excluding motor parameters 04 : backup user's current parameters 05 : restore user backup parameters	0	○
<b>F1 group start-stop control</b>				
F1-00	start method	0: direct start 1: Speed tracking and restart 2: Pre-excitation start 3: SVC quick start	0	○
F1-01	speed tracking method	0: start from stop frequency 1: Start from power frequency 2: Start from the maximum frequency	0	○
F1-02	Speed tracking speed	1~100	20	○
F1-03	start frequency	0.00Hz~50.00Hz	0.00Hz	○
F1-04	Starting frequency hold time	0.0s~100.0s	0.0s	○
F1-05	Starting DC braking current/ pre-excitation current	0%~100%	50%	○
F1-06	Start DC braking time/ pre-excitation time	0.0s~100.0s	0.0s	○
F1-07	Acceleration and deceleration mode	0 : linear acceleration and deceleration 1 : Static S-curve 2 : Dynamic S-curve	0	○
F1-08	S-curve start time ratio	0.0%~(100.0%-F1-09)	30.0%	○
F1-09	S-curve end time ratio	0.0%~(100.0%-F1-08)	30.0%	○

F1-10	Shutdown mode	0: decelerate to stop 1: free parking	0	<input type="radio"/>
F1-11	Start frequency of DC braking at stop	0.00Hz ~ maximum frequency	0.00Hz	<input type="radio"/>
F1-12	Stop DC braking waiting time	0.0s~100.0s	0.0s	<input type="radio"/>
F1-13	Stop DC brake current	0%~100%	50%	<input type="radio"/>
F1-14	Stop DC braking time	0.0s~100.0s	0.0s	<input type="radio"/>
F1-15	brake usage	0%~100%	100%	<input type="radio"/>
F1-16	Speed tracking closed loop current KP	0 ~ 1000	Model confirmed	<input checked="" type="radio"/>
F1-17	Speed tracking closed loop current KI	0 ~ 1000	Model confirmed	<input checked="" type="radio"/>
F1-18	Speed tracking current size	30%~200%	Model confirmed	<input checked="" type="radio"/>
F1-19	reserve			
F1-20	reserve			
F1-21	Demagnetization time (SVC valid)	0.00~5.00s	Model confirmed	<input type="radio"/>
<b>F2 group motor parameters</b>				
F2-00	Motor Type Selection	0 : Ordinary asynchronous motor 1 : variable frequency asynchronous motor	0	<input checked="" type="radio"/>
F2-01	Motor rated power	0.1kW~1000.0kW	Model confirmed	<input checked="" type="radio"/>
F2-02	Motor rated voltage	1V~2000V	Model confirmed	<input checked="" type="radio"/>
F2-03	Motor rated current	0.01A~655.35A (inverter power ≤ 55kW) 0.1A~6553.5A (inverter power > 55kW )	Model confirmed	<input checked="" type="radio"/>
F2-04	Motor rated frequency	0.01Hz~ maximum frequency	Model confirmed	<input checked="" type="radio"/>
F2-05	Motor rated speed	1rpm~65535rpm	Model confirmed	<input checked="" type="radio"/>
F2-06	Asynchronous motor stator resistance	0.001Ω~65.535Ω(inverter power ≤ 55kW) 0.0001Ω~6.5535Ω(inverter rate > 55kW )	Tuning parameters	<input checked="" type="radio"/>
F2-07	Asynchronous motor rotor resistance	0.001Ω~65.535Ω(inverter power ≤ 55kW) 0.0001Ω~6.5535Ω(inverter rate > 55kW )	Tuning parameters	<input checked="" type="radio"/>
F2-08	Asynchronous motor leakage inductance	0.01mH~655.35mH(inverter power ≤ 55kW) 0.001mH~65.535mH(inverter power > 55kW)	Tuning parameters	<input checked="" type="radio"/>
F2-09	Mutual inductance reactance of asynchronous motor	0.1mH~6553.5mH(inverter power ≤ 55kW) 0.01mH~655.35mH(inverter power > 55kW)	Tuning parameters	<input checked="" type="radio"/>
F2-10	Asynchronous motor no-load current	0.01A~F2-03(inverter power ≤ 55kW) 0.1A~F2-03 (inverter power > 55kW )	Tuning parameters	<input checked="" type="radio"/>
F2-11~ F2-36	reserve			

F2-3-7	tuning selection	0 : no operation 1 : Parameter tuning of the static part of the asynchronous machine 2 : Dynamic and complete tuning of the asynchronous machine 3 : The asynchronous machine is static and complete tuning	0	⊙
<b>F3 group of vector control parameters</b>				
F3-00	Speed/torque control mode selection	0: speed control 1: Torque control	0	⊙
F3-01	Speed loop proportional gain 1	1~100	30	○
F3-02	Speed loop integration time 1	0.01s~10.00s	0.50s	○
F3-03	Switching frequency 1	0.00~F3-06	5.00Hz	○
F3-04	Speed loop proportional gain 2	1~100	20	○
F3-05	Speed loop integration time 2	0.01s~10.00s	1.00s	○
F3-06	Switching frequency 2	F3-03 ~ maximum frequency	10.00Hz	○
F3-07	Vector control slip gain	50%~200%	100%	○
F3-08	SVC speed feedback filter time	0.000s~0.100s	0.015s	○
F3-09	reserve			
F3-10	Torque upper limit command selection in speed control mode	0 : set by parameter F3-11 1 : AI1 2 : AI2 3 : AI3 4 : HDI Pulse 5 : Communication setting 6 : MIN(AI1,AI2) 7 : MAX(AI1,AI2) The full range of options 1-7 corresponds to F3-11	0	○
F3-11	Torque upper limit digital setting in speed control mode	0.0%~200.0%	150.0%	○
F3-12	Torque upper limit command selection (power generation) in speed control mode	0 : Parameter F3-11 setting (no distinction between motoring and power generation) 1 : AI1 2 : AI2 3 : AI3 4 : HDI Pulse setting 5 : Communication setting 6 : MIN(AI1,AI2) 7 : MAX(AI1, AI2) 8 : Parameter F3-13 setting The full scale of option 1-8 corresponds to F3-13	0	○

F3-13	Torque upper limit in speed control mode word setting (power generation)	0.0% ~ 200.0%	150.0%	○
F3-14	Excitation regulation proportional gain	0~60000	2000	○
F3-15	Excitation regulation integral gain	0~60000	1300	○
F3-16	Torque regulation proportional gain	0~60000	2000	○
F3-17	Torque adjustment integral gain	0~60000	1300	○
F3-18	Speed Loop Integral Properties	Units: Integral separation 0 : invalid 1 : active	0	○
F3-19	reserve			
F3-20	reserve			
F3-21	reserve			
F3-22	reserve			
F3-23	Generation power limit enable	0 : invalid 1 : Full effect	0	○
F3-24	Generating power upper limit	0.0~200.0%	Model confirmed	○
F3-25	Torque setting selection in torque control mode	0 : Digital setting (F3-27) 1 : AI1 2 : AI2 3 : AI3 4 : HDI pulse 5 : Communication setting 6 : MIN(AI1,AI2) 7 : MAX(AI1,AI2) ( Full scale of option 1-7 , corresponding to F3-27 digital setting)	0	⊙
F3-26	reserve			
F3-27	Torque digital setting in torque control mode	-200.0%~200.0%	150.0%	○
F3-28	reserve			
F3-29	Torque control forward maximum frequency	0.00Hz~ maximum frequency	50.00Hz	○
F3-30	Torque control reverse maximum frequency	0.00Hz~ maximum frequency	50.00Hz	○
F3-31	Torque rise filter time	0.00s~650.00s	0.00s	○
F3-32	Torque drop filter time	0.00s~650.00s	0.00s	○
F3-33 ~ F3-42	reserve			

F4 group of V/F control parameters				
F4-00	V/F curve setting	0 : Straight line V/F 1 : Multi-point V/F 2~9 : reserved 10 : V/F complete separation mode 11 : V/F semi-separated mode	0	<input checked="" type="radio"/>
F4-01	torque boost	0.0% : (automatic torque boost) 0.1%~30.0%	Model confirmed	<input type="radio"/>
F4-02	Torque boost cut-off frequency	0.00Hz~ maximum frequency	50.00Hz	<input checked="" type="radio"/>
F4-03	Multi-point V/F frequency point 1	0.00Hz~F4-05	0.00Hz	<input checked="" type="radio"/>
F4-04	Multi-point V/F voltage point 1	0.0%~100.0%	0.0%	<input checked="" type="radio"/>
F4-05	Multi-point V/F frequency point 2	F4-03~F4-07	0.00Hz	<input checked="" type="radio"/>
F4-06	Multi-point V/F voltage point 2	0.0%~100.0%	0.0%	<input checked="" type="radio"/>
F4-07	Multi-point V/F frequency point 3	F4-05~ motor rated frequency (F2-04)	0.00Hz	<input checked="" type="radio"/>
F4-08	Multi-point V/F voltage point 3	0.0%~100.0%	0.0%	<input checked="" type="radio"/>
F4-09	V/F slip compensation gain	(0.0~200.0)%	0.0%	<input type="radio"/>
F4-10	V/F overexcitation gain	0~200	64	<input type="radio"/>
F4-11	V/F oscillation suppression gain	0~100	40	<input type="radio"/>
F4-12	reserve			
F4-13	V/F separated voltage source	0 : digital setting ( F4-14 ) 1 : AI1 2 : AI2 3 : AI3 4 : pulse setting ( HDI ) 5 : Multi-segment instruction 6 : Simple PLC 7 : PID 8 : Communication setting Note: 100.0% corresponds to the rated voltage of the motor	0	<input type="radio"/>
F4-14	V/F separation	0V~ motor rated voltage	0V	<input type="radio"/>
F4-15	V/F separation	0.0s~1000.0s Note: Indicates the time from 0V to the rated voltage of the motor	0.0s	<input type="radio"/>
F4-16	V/F separation	0.0s~1000.0s Note: Indicates the time from the rated voltage of the motor to 0V	0.0s	<input type="radio"/>

F4-17	V/F separation stop mode selection	0 : frequency / voltage independently reduced to 0 1 : After the voltage is reduced to 0, the frequency will be reduced again	0	○
F4-18	Overrun stall action current	50~200%	150%	◎
F4-19	Overrun stall enable	0 : invalid 1 : active	1 (active)	◎
F4-20	Overflow stall suppression gain	0~100	20	○
F4-21	Double speed overflow stall action current compensation coefficient	50~200%	50%	◎
F4-22	Overvoltage stall action voltage	380V model: 650.0V~800.0V; 220V model: 320.0V~800.0V	380V model: 760V; 220V model: 380V	◎
F4-23	Overvoltage stall enable	0 : invalid 1 : valid	1 (active)	◎
F4-24	Overvoltage stall suppression frequency gain	0~100	30	○
F4-25	Overvoltage stall suppression voltage gain	0~100	30	○
F4-26	Overvoltage stall maximum rise frequency limit	0~50Hz	5Hz	◎
F4-27 ~ F4-50	reserve			
<b>F5 group of input terminals</b>				
F5-00	X1 terminal function selection	0 : no function 1 : Forward run FWD or run command 2 : Reverse running REV or forward and reverse running direction (Note: when it is set to 1 or 2 , it needs to be used in conjunction with F5-11 , see parameters for details Parameter Description) 3 : Three-wire operation control 4 : forward jogging ( FJOG ) 5 : reverse jog ( RJOG ) 6 : Terminal UP 7 : Terminal DOWN 8 : free parking 9 : Fault reset ( RESET ) 10 : Running paused 11 : External fault normally open input 12 : Multi-segment command terminal 1 13 : Multi-segment command terminal 2 14 : multi-segment command terminal 3 15 : multi-segment command terminal 4 16 : Acceleration and deceleration time selection terminal 1	1	◎
F5-01	X2 terminal function selection		4	◎
F5-02	X3 terminal function selection		9	◎
F5-03	X4 terminal function selection		12	◎
F5-04	HDI terminal function selection		13	◎
F5-05	reserve		0	
F5-06	reserve		0	
F5-07	reserve		0	
F5-08	reserve	0		



F5-09	reserve	17 : Acceleration and deceleration time selection terminal 2 18 : Frequency command switching 19 : UP/DOWN setting reset (terminal, keyboard) 20 : Control command switching terminal 1 21 : Acceleration and deceleration prohibited 22 : PID pause 23 : Simple PLC status reset 24 : Wobble pause 25 : Counter input 26 : Counter reset 27 : length count input 28 : length reset 29 : Torque control prohibited 30 : Pulse frequency input(only valid for HDI) 31 : reserved 32 : Immediate DC braking 33 : External fault normally closed input 34 : Frequency modification enable 35 : The direction of PID action is reversed 36 : External parking terminal 1 37 : Control command switching terminal 2 38 : PID integral pause 39 : switch between main frequency and preset frequency 40 : switch between auxiliary frequency and preset frequency 41 : Motor terminal selection function 42 : reserved 43 : PID parameter switching 44 : User-defined fault 1 45 : User-defined fault 2 46 : Speed control / torque control switching 47 : emergency stop 48 : External parking terminal 2 49 : Deceleration DC braking 50 : The current running time is cleared 51 : Two-wire / three-wire switching 52 : Reverse frequency forbidden 53-63 : Reserved	0	
F5-10	X terminal	0.000s~1.000s	0.010s	○
F5-11	Terminal command mode	0 : Two-wire type 1 1 : Two-wire type 2 2 : Three-wire type 1 3 : Three-wire type 2	0	⊙

F5-12	Terminal UP/DOWN change rate	0.001Hz/s~65.535Hz/s	1.00Hz/s	<input type="radio"/>
F5-13	AI curve 1 minimum input	0.00V~F5-15	0.00V	<input type="radio"/>
F5-14	AI curve 1 minimum input corresponding setting	-100.0%~+100.0%	0.0%	<input type="radio"/>
F5-15	AI curve 1 maximum input	F5-13~+10.00V	10.00V	<input type="radio"/>
F5-16	AI curve 1 maximum input corresponding setting	-100.0%~150.0%	100.0%	<input type="radio"/>
F5-17	AI1 filter time	0.00s~10.00s	0.10s	<input type="radio"/>
F5-18	AI curve 2 minimum input	0.00V~F5-20	0.00V	<input type="radio"/>
F5-19	AI curve 2 minimum input corresponding setting	-100.0%~+100.0%	0.0%	<input type="radio"/>
F5-20	AI curve 2 maximum input	F5-18~+10.00V	10.00V	<input type="radio"/>
F5-21	AI curve 2 maximum input corresponding setting	-100.0%~150.0%	100.0%	<input type="radio"/>
F5-22	AI2 filter time	0.00s~10.00s	0.10s	<input type="radio"/>
F5-23	AI curve 3 minimum input	-10.00V~F5-25	-10.00V	<input type="radio"/>
F5-24	AI curve 3 minimum input corresponding setting	-100.0%~+100.0%	-100.0%	<input type="radio"/>
F5-25	AI Curve 3 Maximum Input	F5-23~+10.00V	10.00V	<input type="radio"/>
F5-26	AI curve 3 maximum input corresponding setting	-100.0%~150.0%	100.0%	<input type="radio"/>
F5-27	AI3 filter time	0.00s~10.00s	0.10s	<input type="radio"/>
F5-28	Pulse input minimum frequency	0.00kHz~F5-30	0.00kHz	<input type="radio"/>
F5-29	Pulse minimum input frequency corresponding setting	-100.0%~100.0%	0.0%	<input type="radio"/>
F5-30	Pulse maximum input frequency	F5-28~100.00kHz	50.00kHz	<input type="radio"/>
F5-31	Corresponding setting of pulse maximum input frequency	-100.0%~100.0%	100.0%	<input type="radio"/>
F5-32	Pulse filter time	0.00s~10.00s	0.10s	<input type="radio"/>
F5-33	AI curve selection	Units: AI1 curve selection 1 : Curve 1 ( 2 points, see F5-13~F5-16 ) 2 : Curve 2 ( 2 points, see F5-18~F5-21 ) 3 : Curve 3 ( 2 points, see F5-23~F5-26 ) 4 : Curve 4 ( 4 points, see A0-00~A0-07 ) 5 : Curve 5 ( 4 points, see A0-08~A0-15 ) Tens place: AI2 curve selection, same as above Hundreds place: AI3 curve selection, same as above	321	<input type="radio"/>

F5-34	AI below minimum input setting selection	Units: AI1 is lower than the minimum input setting selection 0 : corresponding to the minimum input setting 1 : 0.0% Tens place: AI2 is lower than the minimum input setting selection, same as above Hundreds place: AI3 is lower than the minimum input setting selection, same as above	000	○
F5-35	X1 delay time	0.0s~3600.0s	0.0s	○
F5-36	X2 delay time	0.0s~3600.0s	0.0s	○
F5-37	X3 delay time	0.0s~3600.0s	0.0s	○
F5-38	X terminal effective mode selection 1	0 : active high 1 : active low Units: X1 Tens: X2 Hundreds place: X3 Thousands place: X4 Ten thousand digits: HDI	00000	◎
F5-39	reserve			
F5-40	reserve			
F5-41	AI1 measured voltage 1	-10.00V~10.000V	factory calibration	○
F5-42	AI1 display voltage 1	-10.00V~10.000V	factory calibration	○
F5-43	AI1 measured voltage 2	-10.00V~10.000V	factory calibration	○
F5-44	AI1 display voltage 2	-10.00V~10.000V	factory calibration	○
F5-45	AI2 measured voltage 1	-10.00V~10.000V	factory calibration	○
F5-46	AI2 display voltage 1	-10.00V~10.000V	factory calibration	○
F5-47	AI2 measured voltage 2	-10.00V~10.000V	factory calibration	○
F5-48	AI2 display voltage 2	-10.00V~10.000V	factory calibration	○
F5-49	AI3 measured voltage 1	-10.00V~10.000V	factory calibration	○
F5-50	AI3 display voltage 1	-10.00V~10.000V	factory calibration	○
F5-51	AI3 measured voltage 2	-10.00V~10.000V	factory calibration	○
F5-52	AI3 display voltage 2	-10.00V~10.000V	factory calibration	○
F5-53	AI2 current calibration measured current 1	0mA~20.000mA	factory calibration	○

F5-54	AI2 current calibration display current 1	0mA~20.000mA	factory calibration	<input type="radio"/>
F5-55	AI2 current calibration measured current 2	0mA~20.000mA	factory calibration	<input type="radio"/>
F5-56	AI2 current calibration display current 2	0mA~20.000mA	factory calibration	<input type="radio"/>
<b>F6 group of digital output terminals DO</b>				
F6-00	HDO terminal output mode selection	0 : Pulse output (HDO) 1 : Switch output (DO)	0	<input type="radio"/>
F6-01	HDO function selection (open collector output terminal)	0 : no output 1 : The inverter is running 2 : Fault output ( fault for freestop ) 3 : Frequency level detection 1 4 : Frequency arrival	0	<input type="radio"/>
F6-02	Control board relay function selection Relay 1	5 : Running at zero speed (no output when stopped)	2	<input type="radio"/>
F6-03	reserve			
F6-04	Control board relay function selection Relay2	6 : Motor overload pre-alarm 7 : Inverter overload pre-alarm 8 : The set count value has reached 9 : The specified count value arrives 10 : length reached 11 : Simple PLC cycle completed 12 : Accumulated running time is reached 13 : frequency limited 14 : Torque limit 15 : ready to run 16 : AI1 > AI2 17 : upper limit frequency reached 18 : The lower limit frequency is reached ( no output when stopped ) 19 : under voltage status 20 : Communication setting 21 : reserved 22 : reserved 23 : Running at zero speed 2(also output when stopped) 24 : Accumulated power-on time is reached 25 : Frequency level detection 2 26 : frequency 1 arrives 27 : frequency 2 arrives 28 : Current 1 reaches 29 : Current 2 reaches 30 : arrive on time 31 : AI1 input over limit 32 : Loading 33 : Reverse running 34 : Zero current state 35 : module temperature reaches 36 : The output current exceeds the limit	1	<input type="radio"/>

F6-05	reserve	37 : The lower limit frequency is reached ( the output is also output when the machine stops ) 38 : Alarm ( all faults ) 39 : motor over temperature 40 : The running time is reached 41 : Fault ( for free stop faultand no output under voltage )		
F6-06	HDO output function selection	0 : operating frequency 1 : set frequency	0	<input type="radio"/>
F6-07	AO1 output function selection	2 : Output current 3 : Motor output torque (absolute value, relative to the percentage of the motor)	0	<input type="radio"/>
F6-08	AO2 output function selection	4 : output power 5 : output voltage 6 : Pulse input (100.0% corresponds to 100.0kHz) 7 : AI1 8 : AI2 9 : AI3 ( expansion card ) 10 : length 11 : counter value 12 : Communication setting 13 : motor speed 14 : Output current (100.0% corresponds to 1000.0A) 15 : output voltage (100.0% corresponds to 1000.0V) 16 : Motor output torque (actual value, relative to the percentage of the motor)	1	<input type="radio"/>
F6-09	HDO output maximum frequency	0.01kHz~100.0kHz	50.00kHz	<input type="radio"/>
F6-10	AO1 zero bias coefficient	-100.0%~+100.0%	0.0%	<input type="radio"/>
F6-11	AO1 gain	-10.00~+10.00	1.00	<input type="radio"/>
F6-12	AO2 zero bias coefficient	-100.0%~+100.0%	0.0%	<input type="radio"/>
F6-13	AO2 Gain	-10.00~+10.00	1.00	<input type="radio"/>
F6-14	reserve			
F6-15	reserve			
F6-16	reserve			
F6-17	HDO output delay time	0.0s~3600.0s	0.0s	<input type="radio"/>
F6-18	RO1 output delay time	0.0s~3600.0s	0.0s	<input type="radio"/>
F6-19	DO1 output delay time	0.0s~3600.0s	0.0s	<input type="radio"/>
F6-20	RO2 output delay time	0.0s~3600.0s	0.0s	<input type="radio"/>
F6-21	DO2 output delay time	0.0s~3600.0s	0.0s	<input type="radio"/>

F6-22	DO output terminal active state selection	0 : positive logic 1 : anti-logic Units: HDO Tens place: RO1 Hundreds place: DO1 Thousands: RO2 Ten thousand digits: DO2	00000	○
F6-23	reserve			
F6-24	AO1 target voltage 1	-10.00V~10.00V	factory calibration	○
F6-25	AO1 measured voltage 1	-10.00V~10.00V	factory calibration	○
F6-26	AO1 target voltage 2	-10.00V~10.00V	factory calibration	○
F6-27	AO1 measured voltage 2	-10.00V~10.00V	factory calibration	○
F6-28	AO2 target voltage 1	-10.00V~10.00V	factory calibration	○
F6-29	AO2 measured voltage 1	-10.00V~10.00V	factory calibration	○
F6-30	AO2 target voltage 2	-10.00V~10.00V	factory calibration	○
F6-31	AO2 measured voltage 2	-10.00V~10.00V	factory calibration	○
F6-32	AO1 ideal current 1	0mA~20.000mA	factory calibration	○
F6-33	AO1 measured current 1	0mA~20.000mA	factory calibration	○
F6-34	AO1 ideal current 2	0mA~20.000mA	factory calibration	○
F6-35	AO1 measured current 2	0mA~20.000mA	factory calibration	○
<b>F7 group of keyboard and display</b>				
F7-00	user password	0~65535	0	○
F7-01	Digital tube self-test	0 : not examine; 1 : all digital tubes lit	0	○
F7-02	MF key function selection	0 : MF is invalid 1 : Operation panel command channel and remote command channel ( terminal command channel or communication command channel ) switch 2 : Forward and reverse switching 3 : forward jogging 4 : reverse jog	0	⊙

F7-03	STOP/RESET key function	0 : Only in the keyboard operation mode , the stop function of the STOP/RES key is valid 1 : In any operation mode , the stop function of STOP/RES key is valid	0	○
F7-04	run display parameter 1	0000~FFFF Bit00: Operating frequency 1(Hz) Bit01: set frequency (Hz) Bit02: Bus voltage (V) Bit03: output voltage (V) Bit04: Output current (A) Bit05: output power (kW) Bit06: Output torque (%) Bit07: X input status Bit08: DO output status Bit09: AI1 voltage (V) Bit10: AI2 voltage (V) Bit11: AI3 voltage (V) Bit12: count value Bit13: length value Bit14: load speed display Bit15: PID setting	1F	○
F7-05	run display parameter 2	0000~FFFF Bit00 : PID feedback Bit01 : PLC stage Bit02 : PULSE input pulse frequency ( kHz ) Bit03 : Feedback frequency 2 ( Hz ) Bit04 : remaining running time Bit05 : AI1 voltage before correction (V) Bit06 : AI2 voltage before correction (V) Bit07 : AI3 voltage before correction (V) Bit08 : Motor speed Bit09 : Current power-on time (Hour) Bit10 : current running time (Min) Bit11 : PULSE input pulse frequency ( Hz ) Bit12 : Communication setting value Bit13 : Encoder feedback speed (Hz) Bit14 : main frequency X display (Hz) Bit15 : Auxiliary frequency Y display (Hz)	0	○

F7-06	Shutdown display parameters	0000~FFFF Bit00 : set frequency (Hz) Bit01 : Bus voltage (V) Bit02 : X input status Bit03 : DO output status Bit04 : AI1 voltage (V) Bit05 : AI2 voltage (V) Bit06 : AI3 voltage (V) Bit07 : count value Bit08 : length value Bit09 : PLC stage Bit10 : load speed Bit11 : PID setting Bit12 : PULSE input pulse frequency ( kHz )	33	○
F7-07	load speed display factor	0.001~6.5000	1.000	○
F7-08	Load speed display decimal point	Units: Number of decimal points in U0-14 0 : 0 decimal places 1 : 1 decimal place 2 : 2 decimal places 3 : 3 decimal places Tens place: Number of decimal points in U0-19/U0-29 1 : 1 decimal place 2 : 2 decimal places	21	○
F7-09	Function parameter group display selection	Units: U group display selection 0 : do not display 1 : display Tens: Group A display selection 0 : do not display 1 : display	11	⊙
F7-10	Personality parameter group display selection	Units: user-defined parameter group display selection 0 : do not display 1 : display Tens place: user change parameter group display selection 0 : do not display 1 : display	00	○
F7-11	Parameter Modification Properties	0 : modifiable 1 : Unmodifiable	0	○
<b>F8 group enhancements</b>				
F8-00	Jog running frequency	0.00Hz ~ maximum frequency 0.00s~650.00s(F0-19=2);	2.00Hz	○
F8-01	jog acceleration time	0.0s~6500.0s(F0-19=1); 0s~65000s(F0-19=0)	20.0s	○
F8-02	Jog deceleration time	0.00s~650.00s(F0-19=2); 0.0s~6500.0s(F0-19=1); 0s~65000s(F0-19=0)	20.0s	○



F8-03	Acceleration time 2	0.00s~650.00s (F0-19=2) 0.0s~6500.0s (F0-19=1) 0s~65000s (F0-19=0)	Model confirmed	<input type="radio"/>
F8-04	Deceleration time 2	0.00s~650.00s (F0-19=2) 0.0s~6500.0s (F0-19=1) 0s~65000s (F0-19=0)	Model confirmed	<input type="radio"/>
F8-05	Acceleration time 3	0.00s~650.00s (F0-19=2) 0.0s~6500.0s (F0-19=1) 0s~65000s (F0-19=0)	Model confirmed	<input type="radio"/>
F8-06	Deceleration time 3	0.00s~650.00s ( F0-19=2 ) 0.0s~6500.0s ( F0-19=1 ) 0s~65000s ( F0-19=0 )	Model confirmed	<input type="radio"/>
F8-07	Acceleration time 4	0.00s~650.00s ( F0-19=2 ) 0.0s~6500.0s ( F0-19=1 ) 0s~65000s ( F0-19=0 )	0.0s	<input type="radio"/>
F8-08	Deceleration time 4	0.00s~650.00s ( F0-19=2 ) 0.0s~6500.0s ( F0-19=1 ) 0s~65000s ( F0-19=0 )	0.0s	<input type="radio"/>
F8-09	jump frequency 1	0.00Hz~ maximum frequency	0.00Hz	<input type="radio"/>
F8-10	jump frequency 2	0.00Hz~ maximum frequency	0.00Hz	<input type="radio"/>
F8-11	Hop Frequency Amplitude	0.00Hz~ maximum frequency	0.00Hz	<input type="radio"/>
F8-12	Forward and reverse dead time	0.0s~3000.0s	0.0s	<input type="radio"/>
F8-13	Reverse Frequency Prohibited	0 : invalid 1 : valid	0	<input type="radio"/>
F8-14	The set frequency is lower than the lower limit frequency operation mode	0 : run at the lower limit frequency 1 : shutdown 2 : Running at zero speed	0	<input type="radio"/>
F8-15	Sag rate	0.00%~10.00%	0.00%	<input type="radio"/>
F8-16	Set the cumulative power-on arrival time	0h~65000h	0h	<input type="radio"/>
F8-17	Set the cumulative running arrival time	0h~65000h	0h	<input checked="" type="radio"/>
F8-18	Boot Protection Selection	0 : no protection 1 : protect	0	<input type="radio"/>
F8-19	Frequency detection value 1	0.00Hz~ maximum frequency	50.00Hz	<input type="radio"/>
F8-20	Frequency detection hysteresis rate 1	0.0%~100.0% ( FDT1 level)	5.0%	<input type="radio"/>
F8-21	Frequency arrival detection range	0.0%~100.0% (maximum frequency)	0.0%	<input type="radio"/>
F8-22	Whether the jump frequency is valid during acceleration and deceleration	0 : invalid 1 : valid	0	<input type="radio"/>
F8-23	reserve			<input type="radio"/>
F8-24	reserve			<input type="radio"/>
F8-25	Acceleration time 1 and acceleration time 2 switching frequency points	0.00Hz~ maximum frequency	0.00Hz	<input type="radio"/>

F8-26	Deceleration time 1 and deceleration time 2 switching frequency points	0.00Hz~ maximum frequency	0.00Hz	<input type="radio"/>
F8-27	Terminal jog priority	0 : invalid 1 : active	0	<input type="radio"/>
F8-28	Frequency detection value 2	0.00Hz~ maximum frequency	50.00Hz	<input type="radio"/>
F8-29	Frequency detection hysteresis rate 2	0.0%~100.0% ( FDT2 level)	5.0%	<input type="radio"/>
F8-30	Arbitrary arrival frequency detection value 1	0.00Hz~ maximum frequency	50.00Hz	<input type="radio"/>
F8-31	Arbitrary arrival frequency detection width 1	0.0%~100.0% (maximum frequency)	0.0%	<input type="radio"/>
F8-32	Arbitrary arrival frequency detection value 2	0.00Hz~ maximum frequency	50.00Hz	<input type="radio"/>
F8-33	Arbitrary arrival frequency detection width 2	0.0%~100.0% (maximum frequency)	0.0%	<input type="radio"/>
F8-34	Zero current detection level	0.0%~300.0% 100.0% corresponds to the rated current of the motor	5.0%	<input type="radio"/>
F8-35	Zero current detection delay time	0.01s~600.00s	0.10s	<input type="radio"/>
F8-36	Output current exceeds limit	0.0% (no detection) 0.1%~300.0% (motor rated current)	200.0%	<input type="radio"/>
F8-37	Output current overrun detection delay time	0.00s~600.00s	0.00s	<input type="radio"/>
F8-38	Arbitrary arrival current 1	0.0%~300.0% ( motor rated current )	100.0%	<input type="radio"/>
F8-39	Arbitrary reaching current 1 amplitude	0.0%~300.0% ( motor rated current )	0.0%	<input type="radio"/>
F8-40	Arbitrary arrival current 2	0.0%~300.0% ( motor rated current )	100.0%	<input type="radio"/>
F8-41	Arbitrary reaching current 2 amplitude	0.0%~300.0% ( motor rated current )	0.0%	<input type="radio"/>
F8-42	Timing function selection	0: Invalid 1: Valid	0	<input checked="" type="radio"/>
F8-43	Timing run time selection	0 : F8-44 setting 1 : AI1 2 : AI2 3 : AI3 Analog input range corresponds to F8-44	0	<input checked="" type="radio"/>
F8-44	Timing run time	0.0Min~6500.0Min	0.0Min	<input checked="" type="radio"/>
F8-45	AI1 input voltage protection value lower limit	0.00V~F8-46	3.10V	<input type="radio"/>
F8-46	AI1 input voltage protection upper limit	F8-45~10.00V	6.80V	<input type="radio"/>
F8-47	Module temperature reaches	0 °C ~100 °C	75 °C	<input type="radio"/>
F8-48	Cooling Fan Control	0: The fan runs while running 1: The fan runs all the time	0	<input checked="" type="radio"/>
F8-49	wakeup frequency	Sleep frequency (F8-51) ~ maximum frequency ( F0-10)	0.00Hz	<input type="radio"/>
F8-50	wake up delay time	0.0s~6500.0s	0.0s	<input type="radio"/>

F8-51	sleep frequency	0.00Hz~ wake-up frequency( F8-49)	0.00Hz	<input type="radio"/>
F8-52	sleep delay time	0.0s~6500.0s	0.0s	<input type="radio"/>
F8-53	Arrival time for this run	0.0~6500.0 minutes	0.0Min	<input checked="" type="radio"/>
F8-54	Output power correction factor	0.00%~200.0%	100.0%	<input type="radio"/>
F8-55	DPWM switching upper limit frequency	5.00Hz~ maximum frequency	8.00Hz	<input type="radio"/>
F8-56	PWM modulation method	0 : asynchronous modulation 1 : synchronous modulation	0	<input type="radio"/>
F8-57	Dead zone compensation mode selection	0 : no compensation 1 : compensation mode	1	<input type="radio"/>
F8-58	Random PWM Depth	0 : Random PWM is invalid 1~10 : PWM carrier frequency random depth	0	<input type="radio"/>
F8-59	Fast current limit enable	0 : disable 1 : enable	1	<input type="radio"/>
F8-60	Voltage overmodulation coefficient	100~110	105	<input checked="" type="radio"/>
F8-61	Undervoltage point setting	380V model: 150.0V~420.0V; 220V model: 150.0V~420.0V		<input type="radio"/>
F8-62	reserve			
F8-63	reserve			
F8-64	Overvoltage point setting	380V model: 330.0V~820.0V; 220V model: 330.0V~400.0V		<input checked="" type="radio"/>
F8-65	reserve			
F8-66	Dynamic braking lower limit voltage			
F8-67 ~ F8-74	reserve			

F9 group of PID functions				
F9-00	PID given source	0 : F9-01 set up 1 : AI1 2 : AI2 3 : AI3 4 : Pulse setting(HDI) 5 : Communication setting 6 : Multi-segment instruction given	0	○
F9-01	PID number given	0.0%~100.0%	50.0%	○
F9-02	PID feedback source	0 : AI1 1 : AI2 2 : AI3 3 : AI1-AI2 4 : HDI pulse 5 : Communication setting 6 : AI1+AI2 7 : MAX( AI1 ,  AI2 ) 8 : MIN( AI1 ,  AI2 )	0	○
F9-03	PID action direction	0 : positive action 1 : Reactive	0	○
F9-04	PID given feedback range	0~65535	1000	○
F9-05	Proportional gain Kp1	0.0~1000.0	20.0	○
F9-06	Integration time Ti1	0.01s~10.00s	2.00s	○
F9-07	Derivative time Td1	0.000s~10.000s	0.000s	○
F9-08	PID inversion cut-off frequency	0.00Hz~ Maximum frequency	0.00Hz	○
F9-09	PID deviation limit	0.0%~100.0%	0.0%	○
F9-10	PID differential limiter	0.00%~100.00%	0.10%	○
F9-11	PID given change time	0.00~650.00s	0.00s	○
F9-12	PID feedback filter time	0.00~60.00s	0.00s	○
F9-13	PID output filter time	0.00~60.00s	0.00s	○
F9-14	reserve	-	-	○
F9-15	Proportional gain Kp2	0~1000.0	20.0	○
F9-16	Integration time Ti2	0.01s~10.00s	2.00s	○
F9-17	Derivative time Td2	0.000s~10.000s	0.000s	○
F9-18	PID parameter switching condition	0 : do not toggle 1 : switch by X terminal 2 : Automatic switching according to the deviation 3 : Automatic switching according to the operating frequency	0	○
F9-19	PID parameter switching deviation 1	0.0%~F9-20	20.0%	○
F9-20	PID parameter switching deviation 2	F9-19~100.0%	80.0%	○
F9-21	PID initial value	0.0%~100.0%	0.0%	○

F9-22	PID initial value hold time	0.00~650.00s	0.00s	<input type="radio"/>
F9-23	The maximum value of the positive deviation of the two outputs	(0.00 ~ 100.00)%	1.00%	<input type="radio"/>
F9-24	The maximum value of the reverse deviation of the two outputs	(0.00 ~ 100.00)%	1.00%	<input type="radio"/>
F9-25	PID integral attribute	Units: Integral separation 0 : invalid 1 : active Tens place: whether to stop integration after the output reaches the limit 0 : Continue to integrate 1 : stop integration	00	<input type="radio"/>
F9-26	PID feedback loss detection value	0.0% : No judgment on feedback loss 0.1%~100.0 %	0.0%	<input type="radio"/>
F9-27	PID feedback loss detection time	0.0s~20.0s	0.0s	<input type="radio"/>
F9-28	PID stop operation	0 : no operation at stop 1 : Computing at stop	0	<input type="radio"/>
F9-29	PID super value detection value	0.0% : Do not judge the value of the feedback 0.1 %~ 100 %	0.0%	<input type="radio"/>
F9-30	PID value detection time	0.0s~20.0s	0.0s	<input type="radio"/>
F9-31	reserve			
F9-32	reserve			
F9-33	reserve			
F9-34	set length	0m ~ 65535m	1000m	<input type="radio"/>
F9-35	Actual length	0m ~ 65535m	0m	<input type="radio"/>
F9-36	Pulses per meter	0.1 ~ 6553.5	100	<input type="radio"/>
F9-37	set count value	1 ~ 65535	1000	<input type="radio"/>
F9-38	Specify the count value	1 ~ 65535	1000	<input type="radio"/>
<b>FA group multi-segment instructions, simple PLC</b>				
FA-00	multi-segment instruction 0	-100.0%~100.0%	0.0%	<input type="radio"/>
FA-01	multi-segment instruction 1	-100.0%~100.0%	0.0%	<input type="radio"/>
FA-02	multi-segment instruction 2	-100.0%~100.0%	0.0%	<input type="radio"/>
FA-03	multi-segment instruction 3	-100.0%~100.0%	0.0%	<input type="radio"/>
FA-04	multi-segment instruction 4	-100.0%~100.0%	0.0%	<input type="radio"/>
FA-05	multi-segment instruction 5	-100.0%~100.0%	0.0%	<input type="radio"/>
FA-06	multi-segment instruction 6	-100.0%~100.0%	0.0%	<input type="radio"/>
FA-07	multi-segment instruction 7	-100.0%~100.0%	0.0%	<input type="radio"/>
FA-08	multi-segment instruction 8	-100.0%~100.0%	0.0%	<input type="radio"/>
FA-09	multi-segment instruction 9	-100.0%~100.0%	0.0%	<input type="radio"/>
FA-10	multi-segment instruction 10	-100.0%~100.0%	0.0%	<input type="radio"/>
FA-11	multi-segment instruction 11	-100.0%~100.0%	0.0%	<input type="radio"/>
FA-12	multi-segment instruction 12	-100.0%~100.0%	0.0%	<input type="radio"/>
FA-13	multi-segment instruction 13	-100.0%~100.0%	0.0%	<input type="radio"/>
FA-14	multi-segment instruction 14	-100.0%~100.0%	0.0%	<input type="radio"/>

FA-15	multi-segment instruction 15	-100.0%~100.0%	0.0%	<input type="radio"/>
FA-16	Simple PLC operation mode	0 : Stop after a single run 1 : Keep the final value at the end of a single run 2 : keep looping	0	<input type="radio"/>
FA-17	Simple PLC power-down memory selection	Units: power-off memory selection 0 : no memory when power off 1 : power-down memory Tens place: stop memory selection 0 : no memory when shutdown 1 : Shutdown memory	00	<input type="radio"/>
FA-18	Running time of stage 0 of simple PLC	0.0s(h)~6553.5s(h)	0.0s(h)	<input type="radio"/>
FA-19	Simple PLC step 0 acceleration and deceleration time selection	0: Acceleration and deceleration time1 1: Acceleration and deceleration time2 2: Acceleration and deceleration time3 3: Acceleration and deceleration time4	0	<input type="radio"/>
FA-20	Running time of the first stage of simple PLC	0.0s(h)~6553.5s(h)	0.0s(h)	<input type="radio"/>
FA-21	Simple PLC first stage acceleration and deceleration time selection	same as FA-19	0	<input type="radio"/>
FA-22	Running time of the second stage of simple PLC	0.0s(h)~6553.5s(h)	0.0s(h)	<input type="radio"/>
FA-23	Simple PLC second stage acceleration and deceleration time selection	same as FA-19	0	<input type="radio"/>
FA-24	The running time of the third stage of simple PLC	0.0s(h)~6553.5s(h)	0.0s(h)	<input type="radio"/>
FA-25	Selection of acceleration and deceleration time for the third stage of simple PLC	same as FA-19	0	<input type="radio"/>
FA-26	Running time of the fourth stage of simple PLC	0.0s(h)~6553.5s(h)	0.0s(h)	<input type="radio"/>
FA-27	Simple PLC step 4 acceleration and deceleration time selection	same as FA-19	0	<input type="radio"/>
FA-28	Running time of the fifth stage of simple PLC	0.0s(h)~6553.5s(h)	0.0s(h)	<input type="radio"/>
FA-29	Simple PLC step 5 acceleration and deceleration time selection	same as FA-19	0	<input type="radio"/>
FA-30	Running time of the sixth stage of simple PLC	0.0s(h)~6553.5s(h)	0.0s(h)	<input type="radio"/>
FA-31	Simple PLC step 6 acceleration and deceleration time selection	same as FA-19	0	<input type="radio"/>

FA-32	The running time of the seventh stage of simple PLC	0.0s(h)~6553.5s(h)	0.0s(h)	<input type="radio"/>
FA-33	Simple PLC step 7 acceleration and deceleration time selection	same as FA-19	0	<input type="radio"/>
FA-34	Running time of the 8th stage of simple PLC	0.0s(h)~6553.5s(h)	0.0s(h)	<input type="radio"/>
FA-35	Simple PLC step 8 acceleration and deceleration time selection	same as FA-19	0	<input type="radio"/>
FA-36	Running time of the 9th stage of simple PLC	0.0s(h)~6553.5s(h)	0.0s(h)	<input type="radio"/>
FA-37	Selection of the acceleration and deceleration time of the 9th stage of simple PLC	same as FA-19	0	<input type="radio"/>
FA-38	Running time of the 10th stage of simple PLC	0.0s(h)~6553.5s(h)	0.0s(h)	<input type="radio"/>
FA-39	Simple PLC step 10 acceleration and deceleration time selection	same as FA-19	0	<input type="radio"/>
FA-40	Running time of the 11th stage of simple PLC	0.0s(h)~6553.5s(h)	0.0s(h)	<input type="radio"/>
FA-41	Simple PLC step 11 acceleration and deceleration time selection	same as FA-19	0	<input type="radio"/>
FA-42	Running time of the 12th stage of simple PLC	0.0s(h)~6553.5s(h)	0.0s(h)	<input type="radio"/>
FA-43	Simple PLC step 12 acceleration and deceleration time selection	same as FA-19	0	<input type="radio"/>
FA-44	Running time of the 13th stage of simple PLC	0.0s(h)~6553.5s(h)	0.0s(h)	<input type="radio"/>
FA-45	Simple PLC step 13 acceleration and deceleration time selection	same as FA-19	0	<input type="radio"/>
FA-46	Running time of the 14th stage of simple PLC	0.0s(h)~6553.5s(h)	0.0s(h)	<input type="radio"/>
FA-47	Simple PLC step 14 acceleration and deceleration time selection	same as FA-19	0	<input type="radio"/>
FA-48	Running time of the 15th stage of simple PLC	0.0s(h)~6553.5s(h)	0.0s(h)	<input type="radio"/>
FA-49	Simple PLC step 15 acceleration and deceleration time selection	same as FA-19	0	<input type="radio"/>
FA-50	Simple PLC running time unit	0 : s (second) 1 : h (hour)	0	<input type="radio"/>

FA-51	Multi-segment instruction 0 given mode	0 : parameter FA-00 given 1 : AI1 2 : AI2 3 : AI3 4 : Pulse 5 : PID 6 Preset frequency ( F0-08 ) given, UP/DOWN can be modified	0	<input type="radio"/>
<b>Fb group communication parameters</b>				
Fb-00	Communication Protocol Selection	0: Modbus protocol 1: Profibus-DP, CANopen, Profinet, EtherCAT protocol	0	<input checked="" type="radio"/>
Fb-01	Communication baud rate	Units: Modbus 0 : 300BPS 1 : 600BPS 2 : 1200BPS 3 : 2400BPS 4 : 4800BPS 5 : 9600BPS 6 : 19200BPS 7 : 38400BPS 8 : 57600BPS 9 : 115200BPS Tens: Profibus-DP 0 : 115200BPS 1 : 208300BPS 2 : 256000BPS 3 : 512000Bps Hundreds place: Reserved Thousands: CANlink baud rate 0 : 20 1 : 50 2 : 100 3 : 125 4 : 250 5 : 500 6 : 1M	5005	<input type="radio"/>
Fb-02	Modbus data format	0 : no parity (8-N-2) 1 : even parity (8-E-1) 2 : Odd parity (8-O-1) 3 : no parity (8-N-1) (Modbus valid )	0	<input type="radio"/>
Fb-03	local address	0 : broadcast address 1 ~ 247 (Modbus , Profibus-DP , CANlink , Profinet , EtherCAT valid )	0	<input type="radio"/>
Fb-04	Modbus response delay	0~20ms (Modbus valid )	2	<input type="radio"/>



Fb-05	Serial communication timeout	0.0 : invalid 0.1 ~ 60.0s (Modbus , Profibus-DP , CANopen , Profinet , EtherCAT valid )	0.0	<input type="radio"/>
Fb-06	Data transfer format selection	Units : Modbus 0: non-standard Modbus protocol 1: Standard Modbus protocol	1	<input type="radio"/>
Fb-07	Communication reading current resolution	0 : 0.01A ( effective when $\leq 55\text{kW}$ ) 1 : 0.1A	0	<input type="radio"/>
Fb-08	reserve			
Fb-09	Profibus-DP , CANopen , In Profinet and EtherCAT communication break detection time	0.0s : invalid 0.1~60.0s	0	<input type="radio"/>
Fb-10	reserve			

FC (Reserved )

Fd group expansion card				
Fd-00	Encoder lines	1~65535	1024	<input type="radio"/>
Fd-01	encoder type	0 : ABZ incremental encoder 2 : Resolver	0	<input type="radio"/>
Fd-02	reserve			
Fd-03	ABZ incremental encoder AB phase sequence	0 : Forward 1 : Reverse	0	<input type="radio"/>
Fd-04	reserve			
Fd-05	reserve			
Fd-06	reserve			
Fd-07	Resolver pole pairs	1~65535	1	<input type="radio"/>
Fd-08	reserve			
Fd-09	Speed feedback PG disconnection detection time	0.0s : no action 0.1s~10.0s	0.0s	<input type="radio"/>
Fd-10~ Fd-19	reserve			
FE group Faults and Protections				
FE-00	Motor overload protection selection	0 : disabled 1 : allow	1	<input type="radio"/>
FE-01	Motor overload protection gain	0.20~10.00	1.00	<input type="radio"/>
FE-02	Motor overload warning coefficient	50%~100%	80%	<input type="radio"/>
FE-03	Overvoltage stall gain	0~100	30	<input type="radio"/>
FE-04	Overvoltage stall protection voltage	380V model: 650.0V~800.0V; 220V model: 320.0V~800.0V	380V model: 760V; 220V model: 380V	<input type="radio"/>
FE-05	reserve			
FE-06	reserve			

FE-07	Short-to-ground protection option	Units: power-on short-circuit protection selection 0 : invalid 1 : valid Tens place: selection of short-circuit protection to ground before operation 0 : invalid 1 : active	1	○
FE-08	Starting voltage of brake unit action	380V model: 650.0V~800.0V; 220V model: 320.0V~800.0V	380V model: 690V; 220V model: 360V	○
FE-09	Fault automatic reset times	0~ 30	0	○
FE-10	DO during fault automatic reset action selection	0 : no action 1 : action	1	○
FE-11	Fault automatic reset waiting time	0.1s~100.0s	6.0s	○
FE-12	Input phase loss / contactor pick-up protection selection	Units: input phase loss protection selection 0 : Disable input phase loss protection 1 : Simultaneous detection of software and hardware input phase loss protection 2 : Enable software input phase loss protection 3 : Enable hardware input phase loss protection Tens place: contactor pick-up protection selection 0 : disabled 1 : allow	11	○
FE-13	Output phase loss protection selection	Units: output phase loss protection selection 0 : disabled 1 : allow Tens place: output phase loss protection selection before operation 0 : disabled 1 : allow	01	○
FE-14	first failure type	0 : no fault 1 : reserved 2 : Acceleration overcurrent 3 : deceleration overcurrent 4 : Constant speed overcurrent 5 : Acceleration overvoltage	-	●
FE-15	Second failure type	6 : Deceleration overvoltage 7 : Constant speed overvoltage 8 : The snubber resistor is overloaded 9 : Undervoltage 10 : Inverter overload 11 : Motor overload	-	●

FE-16	Third ( most recent ) failure class type	12 : Input phase loss 13 : Output phase loss 14 : module overheating 15 : External fault 16 : Abnormal communication 17 : Abnormal contactor 18 : Abnormal current detection 19 : Abnormal motor tuning 20 : Encoder /PG card abnormal 21 : Abnormal reading and writing of parameters 22 : Inverter hardware abnormality 23 : The motor is short-circuited to the ground 24 : PID overvalue at runtime 25 : reserved 26 : run time reached 27 : User-defined fault 1 28 : User-defined fault 2 29 : Power-on time arrives 30 : load off 31 : PID feedback lost during runtime 40 : The per-wave current limiting fault 41 : switch motors while running 42 : The speed deviation is too large 43 : Motor overspeed 45 : motor over temperature 51 : initial position error 55 : Slave machine failure during master-slave control 61 : Break unit overload 62 : Break circuit short circuit	-	●
FE-17	Frequency at the third(most recent)failure	0.00Hz~655.35Hz	0.00Hz	●
FE-18	the third ( latest )fault	0.00A~655.35A	0.00A	●
FE-19	Bus voltage at the third ( latest ) fault	0.0V~6553.5V	0.0V	●
FE-20	the third ( latest )fault	0~9999	0	●
FE-21	Output terminal status at the third ( latest ) fault	0~9999	0	●
FE-22	the third ( latest )fault	0~65535	0	●
FE-23	Power-on time at the third ( most recent )failure	0s~65535s	0s	●
FE-24	Uptime on third ( most recent ) failure	0.0s~6553.5s	0.0s	●
FE-25	reserve			
FE-26	reserve			
FE-27	Frequency at second failure	0.00Hz~655.35Hz	0.00Hz	●
FE-28	Current at second fault	0.00A~655.35A	0.00A	●
FE-29	Bus voltage at second fault	0.0V~6553.5V	0.0V	●

FE-30	Input terminal status at the second fault	0~9999	0	●
FE-31	Output terminal status at the second fault	0~9999	0	●
FE-32	Inverter status at the time of the second fault	0~65535	0	●
FE-33	Power-on time at the second fault	0s~65535s	0s	●
FE-34	Run time on second failure	0.0s~6553.5s	0.0s	●
FE-35	reserve			
FE-36	reserve			
FE-37	Frequency at first failure	0.00Hz~655.35Hz	0.00Hz	●
FE-38	Current at the first fault	0.00A~655.35A	0.00A	●
FE-39	Bus voltage at first fault	0.0V~6553.5V	0.0V	●
FE-40	Input terminal status at the first fault	0~9999	0	●
FE-41	Output terminal status at the first fault	0~9999	0	●
FE-42	Inverter status at the first fault	0~65535	0	●
FE-43	Power-on time at first failure	0s~65535s	0s	●
FE-44	Uptime to first failure	0.0s~6553.5s	0.0s	●
FE-45	reserve			
FE-46	reserve			
FE-47	Failsafe action selection 1	Units: motor overload (E.O1) 0 : free stop 1 : Shut down according to the shutdown mode 2 : keep running Tens place: input phase loss (E.SPI)(Same as units) Hundreds place: output phase loss (E.SPO)(Same as units) Thousands place: external fault (E.EF)(Same as units) Ten thousand digit: communication error (E.CE)(Same as units)	00000	○
FE-48	Failsafe action selection 2	Units: Encoder /PG card abnormality (E.ENCD) 0 : free stop Tens digit: Parameter reading and writing exception (E.EEP) 0 : free stop 1 : Shut down according to the shutdown mode Hundreds place: PID feedback overvalue during operation( E.FBH )(Same as units of FE-47) Thousands: reserved Ten thousand digit: run time arrival (E.RTO)	00000	○

FE-49	Failsafe Action Selection 3	<p>Units: user-defined fault 1 (E.US1)  0 : free stop  1 : Shut down according to the shutdown mode  2 : keep running</p> <p>Tens: user-defined fault 2 (E.US2)  0 : free stop  1 : Shut down according to the shutdown mode  2 : keep running</p> <p>Hundreds place: power-on time arrival (E.PTO)  0 : free stop  1 : Shut down according to the shutdown mode  2 : keep running</p> <p>Thousands place: load drop(E.LL)  0 : free stop  1 : decelerate to stop  2 : Jump directly to 7% of the rated frequency of the motor and continue to run without load loss  Automatically return to the set frequency operation</p> <p>PID feedback loss during runtime (E.FBL)  0 : free stop  1 : Shut down according to the shutdown mode  2 : keep running</p>	00000	○
FE-50	Failsafe Action Selection 4	<p>Units: Excessive speed deviation (E.DEV)  0 : free stop  1 : Shut down according to the shutdown mode  2 : keep running</p> <p>Tens digit: motor overspeed (E.OS)  (Same as units)</p> <p>Hundreds place: initial position error (E.POS)  (Same as units)</p>	00000	○
FE-51	reserve			
FE-52	reserve			
FE-53	reserve			
FE-54	Continue to run frequency selection in case of failure	<p>0 : run at the current operating frequency  1 : Run at the set frequency  2 : Run at upper limit frequency  3 : Run at the lower limit frequency  4 : Run at abnormal standby frequency</p>	0	○
FE-55	Abnormal standby frequency	<p>0.0%~100.0%  (100.0% corresponds to the maximum frequency F0-10)</p>	100.0%	○

FE-56	Motor temperature sensor type	0 : no temperature sensor 1 : PT100 2 : PT1000	0	<input type="radio"/>
FE-57	Motor overheat protection threshold	0 °C ~200 °C	110 °C	<input type="radio"/>
FE-58	Motor overheating pre-alarm threshold	0 °C ~200 °C	90 °C	<input type="radio"/>
FE-59	Instantaneous stop non-stop function selection	0~2 0 : invalid 1 : Bus voltage constant control 2 : Deceleration to stop	0	<input checked="" type="radio"/>
FE-60	Instantaneous power failure non-stop recovery voltage	80%~100%	85%	<input checked="" type="radio"/>
FE-61	Judgment time for instantaneous power failure and non-stop voltage recovery	0.0~100.0s	0.5S	<input checked="" type="radio"/>
FE-62	Momentary stop non-stop action voltage	60%~100%	80%	<input checked="" type="radio"/>
FE-63	Instantaneous stop non-stop gain Kp	0~100	40	<input type="radio"/>
FE-64	Instantaneous stop non-stop integral coefficient Ki	0~100	30	<input type="radio"/>
FE-65	Momentary stop non-stop action deceleration time	0~300.0s	20.0s	<input checked="" type="radio"/>
FE-66	Load Loss Protection Selection	0 : invalid 1 : active	0	<input type="radio"/>
FE-67	Load drop detection level	0.0~100.0 %	10.0%	<input type="radio"/>
FE-68	Load drop detection time	0.0~60.0s	1.0s	<input type="radio"/>
FE-69	reserve			
FE-70	over speed detection value	0.0 % ~ 50.0 % (maximum frequency )	20.0%	<input type="radio"/>
FE-71	over speed detection time	0.0s : no detection 0.1~60.0s	1.0s	<input type="radio"/>
FE-72	Excessive speed deviation detection value	0.0 % ~50.0 % (maximum frequency )	20.0%	<input type="radio"/>
FE-73	Excessive speed deviation detection time	0.0s : no detection 0.1~60.0s	5.0s	<input type="radio"/>
FE-74	Software input phase loss sensitivity	1 ~ 50	5	<input type="radio"/>
FE-75	Software input phase loss filter times	1 ~ 50	20	<input type="radio"/>
FE-76	reserve			
FE-77	reserve			
FE-78	reserve			
FE-79	reserve			
FE-80	reserve			

FF group user-defined parameters				
FF-00	user parameter 0		F0-00	<input type="radio"/>
FF-01	user parameter 1		F0-00	<input type="radio"/>
FF-02	user parameter 2		F0-00	<input type="radio"/>
FF-03	user parameter 3		F0-00	<input type="radio"/>
FF-04	user parameter 4		F0-00	<input type="radio"/>
FF-05	user parameter 5		F0-00	<input type="radio"/>
FF-06	user parameter 6		F0-00	<input type="radio"/>
FF-07	user parameter 7		F0-00	<input type="radio"/>
FF-08	user parameter 8		F0-00	<input type="radio"/>
FF-09	user parameter 9		F0-00	<input type="radio"/>
FF-10	user parameter 10		F0-00	<input type="radio"/>
FF-11	user parameter 11		F0-00	<input type="radio"/>
FF-12	user parameter 12		F0-00	<input type="radio"/>
FF-13	user parameter 13		F0-00	<input type="radio"/>
FF-14	user parameter 14		F0-00	<input type="radio"/>
FF-15	user parameter 15	F0-00~FE-xx	F0-00	<input type="radio"/>
FF-16	user parameter 16	A0-00~A5-xx	F0-00	<input type="radio"/>
FF-17	user parameter 17	U0-00~U0-xx	F0-00	<input type="radio"/>
FF-18	user parameter 18		F0-00	<input type="radio"/>
FF-19	user parameter 19		F0-00	<input type="radio"/>
FF-20	user parameter 20		F0-68	<input type="radio"/>
FF-21	user parameter 21		F0-69	<input type="radio"/>
FF-22	user parameter 22		F0-00	<input type="radio"/>
FF-23	user parameter 23		F0-00	<input type="radio"/>
FF-24	user parameter 24		F0-00	<input type="radio"/>
FF-25	user parameter 25		F0-00	<input type="radio"/>
FF-26	user parameter 26		F0-00	<input type="radio"/>
FF-27	user parameter 27		F0-00	<input type="radio"/>
FF-28	user parameter 28		F0-00	<input type="radio"/>
FF-29	user parameter 29		F0-00	<input type="radio"/>
FF-30	user parameter 30		F0.00	<input type="radio"/>
FF-31	user parameter 31		F0-00	<input type="radio"/>
A0 Group terminal function expansion				
A0-00	AI curve 4 minimum input	-10.00V~A0-02	0.00V	<input type="radio"/>
A0-01	AI curve 4 minimum input corresponding setting	-100.0%~+100.0%	0.0%	<input type="radio"/>
A0-02	AI curve 4 inflection points 1 input	A0-00~A0-04	3.00V	<input type="radio"/>
A0-03	AI curve 4 inflection point 1 input corresponding setting	-100.0%~+100.0%	30.0%	<input type="radio"/>
A0-04	AI curve 4 inflection point 2 input	A0-02~A0-06	6.00V	<input type="radio"/>

A0-05	AI curve 4 inflection point 2 input corresponding setting	-100.0%~+100.0%	60.0%	<input type="radio"/>
A0-06	AI Curve 4 Maximum Input	A0-04~+10.00V	10.00V	<input type="radio"/>
A0-07	AI curve 4 maximum input corresponding setting	-100.0%~+100.0%	100.0%	<input type="radio"/>
A0-08	AI curve 5 minimum input	-10.00V~A0-10	-10.00V	<input type="radio"/>
A0-09	AI curve 5 minimum input corresponding setting	-100.0%~+100.0%	-100.0%	<input type="radio"/>
A0-10	AI curve 5 inflection points 1 input	A0-08~A0-12	-3.00V	<input type="radio"/>
A0-11	AI curve 5 inflection point 1 input corresponding setting	-100.0%~+100.0%	-30.0%	<input type="radio"/>
A0-12	AI curve 5 inflection points 2 inputs	A0-10~A0-14	3.00V	<input type="radio"/>
A0-13	AI curve 5 inflection point 2 input corresponding setting	-100.0%~+100.0%	30.0%	<input type="radio"/>
A0-14	AI Curve 5 Maximum Input	A0-12~+10.00V	10.00V	<input type="radio"/>
A0-15	AI curve 5 maximum input corresponding setting	300.00%	100.0%	<input type="radio"/>
A0-16 ~ A0-23	reserve			
A0-24	AI1 sets the jump point	-100.0%~100.0%	0.0%	<input type="radio"/>
A0-25	AI1 sets the jump range	0.0%~100.0%	0.1%	<input type="radio"/>
A0-26	AI2 set jump point	-100.0%~100.0%	0.0%	<input type="radio"/>
A0-27	AI2 sets the jump range	0.0%~100.0%	0.1%	<input type="radio"/>
A0-28	AI3 set jump point	-100.0%~100.0%	0.0%	<input type="radio"/>
A0-29	AI3 set jump range	0.0%~100.0%	0.1%	<input type="radio"/>
A0-30	Virtual VDI1 terminal function selection	0~63	0	<input type="radio"/>
A0-31	Virtual VDI2 terminal function selection	0~63	0	<input type="radio"/>
A0-32	Virtual VDI3 terminal function selection	0~63	0	<input type="radio"/>
A0-33	Virtual VDI4 terminal function selection	0~63	0	<input type="radio"/>
A0-34	Virtual VDI5 terminal function selection	0~63	0	<input type="radio"/>



A0-35	Virtual VDI terminal valid state setting mode	Ones place: virtual VDI1	0	○
		Tens: Virtual VDI2		
		Hundreds place: virtual VDI3		
		Thousands: Virtual VDI4		
		Ten thousand digits: Virtual VDI5		
		0 : Whether the VDI is valid or not is determined by the state of the virtual VDOx		
		1 : Whether VDI is valid or not is set by parameter A0-36		
A0-36	Virtual VDI terminal status setting	0 : invalid	0	○
		1 : active		
		Ones place: virtual VDI1		
		Tens: Virtual VDI2		
		Hundreds place: virtual VDI3		
		Thousands: Virtual VDI4		
		Ten thousand digits: Virtual VDI5		
A0-37	Function selection when AI1 terminal is used as X	0~63	0	○
A0-38	Function selection when AI2 terminal is used as X	0~63	0	○
A0-39	AI3 terminal is used as X function selection	0~63	0	○
A0-40	AI terminal as X effective mode	0 : active high	0	○
		1 : active low		
		Units: AI1		
		Tens place: AI2		
		Hundreds place: AI3		
A0-41	Virtual VDO1 Output function selection	0: Shorted internally with the physical DIx	0	○
		1~41: see F6 group physical DO output selection		
A0-42	Virtual VDO2 output function selection	0: Shorted internally with the physical DIx	0	○
		1~41: see F6 group physical DO output selection		
A0-43	Virtual VDO3 output function selection	0: Shorted internally with the physical DIx	0	○
		1~41: see F6 group physical DO output selection		
A0-44	Virtual VDO4 output function selection	0: Shorted internally with the physical DIx	0	○
		1~41: see F6 group physical DO output selection		
A0-45	Virtual VDO5 output function selection	0: Shorted internally with the physical DIx	0	○
		1~41: see F6 group physical DO output selection		
A0-46	VDO1 output delay time	0.0s~3600.0s	0.0s	○
A0-47	VDO2 output delay time	0.0s~3600.0s	0.0s	○
A0-48	VDO3 output delay	0.0s~3600.0s	0.0s	○
A0-49	VDO4 output delay	0.0s~3600.0s	0.0s	○
A0-50	VDO5 output delay time	0.0s~3600.0s	0.0s	○

A0-51	VDO output terminal is valid	0 : Positive logic 1 : reverse logic Units: VDO1 Tens: VDO2 Hundreds place: VDO3 Thousands: VDO4 Ten thousand digits: VDO5	0	○
<b>A5 group of second motor parameters</b>				
A5-00	Motor Type Selection	0: Ordinary asynchronous motor 1: Frequency conversion asynchronous motor	0	○
A5-01	Motor rated power	0.1KW~6553.5KW	Model confirmed	○
A5-02	Motor rated voltage	1V~2000V	Model confirmed	○
A5-03	Motor rated current	0.01A~655.35A (inverter power ≤ 55kW) 0.1A~6553.5A (inverter power > 55kW)	Model confirmed	○
A5-04	Motor rated frequency	0.01Hz~ maximum frequency	Model confirmed	○
A5-05	Motor rated speed	1rpm~65535rpm	Model confirmed	○
A5-06	Asynchronous motor stator resistance	0.001Ω~ 65.535Ω (inverter power ≤ 55kW) 0.0001Ω ~ 6.5535Ω (inverter rate > 55kW)	Tuning parameters	○
A5-07	Asynchronous motor rotor resistance	0.001Ω~ 65.535Ω (inverter power ≤ 55kW) 0.0001Ω ~ 6.5535Ω (inverter rate > 55kW)	Tuning parameters	○
A5-08	Asynchronous motor leakage inductance	0.01mH~655.35mH (inverter power ≤ 55kW) 0.001mH~65.535mH (inverter power > 55kW)	Tuning parameters	○
A5-09	Mutual inductance reactance of asynchronous motor	0.1mH~6553.5mH (inverter power ≤ 55kW) 0.01mH~655.35mH (inverter power > 55kW)	Tuning parameters	○
A5-10	Asynchronous motor no-load current	0.01A~A5-03 (inverter power ≤ 55kW) 0.1A~A5-03 (inverter power > 55kW)	Tuning parameters	○
A5-11 ~ A5-26	reserve			
A5-27	Encoder lines	1~65535	1024	○
A5-28	encoder type	0: ABZ incremental encoder 2: Resolver	0	○
A5-29	reserve			
A5-30	ABZ incremental encoder AB phase sequence	0: Forward 1: Reverse	0	○
A5-31	reserve			
A5-32	reserve			
A5-33	reserve			
A5-34	Resolver pole pairs	1~65535	1	○
A5-35	reserve			
A5-36	Speed feedback PG disconnection detection time	0.0s: no action 0.1s~10.0s	0.0s	○

A5-37	tuning selection	0: no operation 1: Parameter tuning of the static part of the asynchronous machine 2: Dynamic and complete tuning of the asynchronous machine 3: Asynchronous machine static complete tuning	0	⊙
A5-38	Speed loop proportional gain 1	1~100	30	○
A5-39	Speed loop integration time 1	0.01s~10.00s	0.50s	○
A5-40	Switching frequency 1	0.00~A5-43	5.00Hz	○
A5-41	Speed loop proportional gain 2	1~100	20	○
A5-42	Speed loop integration time 2	0.01s~10.00s	1.00s	○
A5-43	Switching frequency 2	A5-40 ~ maximum frequency	10.00Hz	○
A5-44	Vector control slip gain	50%~200%	100%	○
A5-45	SVC speed feedback filter time	0.000s~1.000s	0.050s	○
A5-46	reserve			
A5-47	Torque upper limit command selection in speed control mode	0: set by parameter A5-48 1: AI1 2: AI2 3: AI3 4: HDI 5: Communication setting 6: MIN(AI1, AI2) 7: MAX(AI1, AI2) The full scale of the option 1-7 corresponds to A5-48	0	○
A5-48	Torque upper limit digital setting in speed control mode	0.0%~200.0%	150.00%	○
A5-49	Torque upper limit command selection (power generation) in speed control mode	0: set by parameter A5-47 (no distinction between motoring and generating) 1: AI1 2: AI2 3: AI3 4: PULSE pulse setting 5: Communication setting 6: MIN(AI1, AI2) 7: MAX(AI1, AI2) 8: Parameter A5-50 setting The full scale of the 1-7 option corresponds to A5-50	0	○

A5-50	Torque upper limit digital setting in speed control mode (power generation)	0.0% ~ 200.0%	150.00%	○
A5-51	Excitation regulation proportional gain	0~60000	2000	○
A5-52	Excitation regulation integral gain	0~60000	1300	○
A5-53	Torque regulation proportional gain	0~60000	2000	○
A5-54	Torque adjustment integral gain	0~60000	1300	○
A5-55	Speed Loop Integral Properties	Units: Integral separation 0: invalid 1: valid	0	○
A5-56	reserve			
A5-57	reserve			
A5-58	reserve			
A5-59	reserve			
A5-60	Generation power limit enable	0: invalid 1: Full effect	0	⊙
A5-61	Generating power upper limit	0.0~200.0%	Model confirmed	○
A5-62	2nd Motor Control Method	0: Speed sensorless vector control(SVC) 1: Speed sensor vector control(FVC) 2: V/F control	0	⊙
A5-63	Acceleration and deceleration time selection of the second motor	0: Same as the first motor 1: Acceleration/deceleration time 1 2: Acceleration/deceleration time 2 3: Acceleration/deceleration time 3 4: Acceleration/deceleration time 4	0	○
A5-64	2nd motor torque boost	0.0%: Automatic torque boost 0.1% ~ 30.0%	Model confirmed	○
A5-65	reserve			○
A5-66	2nd Motor Oscillation Suppression Gain	0 ~100	Model confirmed	○

**U0 group basic monitoring parameters**

Parameter	Name	Smallest unit	Contact address
U0-00	Operating frequency(Hz)	0.01Hz	7000H
U0-01	Set frequency (Hz)	0.01Hz	7001H
U0-02	Bus voltage (V)	0.1V	7002H
U0-03	Output voltage (V)	1V	7003H
U0-04	Output current (A)	0.01A(Inverter power≤55kW); 0.1A(Inverter power > 55kW)	7004H
U0-05	Output power (kW)	0.1kW	7005H
U0-06	Output torque (%)	0.1%	7006H
U0-07	X input state	1	7007H
U0-08	DO output state	1	7008H
U0-09	AI1 voltage (V)	0.01V	7009H
U0-10	AI2 Voltage ( V ) /Current ( mA )	0.01V/0.01mA	700AH
U0-11	AI3 voltage (V)	0.01V	700BH
U0-12	count value	1	700CH
U0-13	length value	1	700DH
U0-14	load speed	1RPM	700EH
U0-15	PID setting	1	700FH
U0-16	PID feedback	1	7010H
U0-17	PLC stage	1	7011H
U0-18	Input pulse frequency(Hz)	0.01kHz	7012H
U0-19	Feedback speed (Hz)	0.01Hz	7013H
U0-20	remaining run time	0.1Min	7014H
U0-21	AI1 voltage before correction	0.001V	7015H
U0-22	Voltage before AI2 correction ( V )	0.001V	7016H
U0-23	AI3 voltage before correction	0.001V	7017H
U0-24	Motor speed	1RPM	7018H
U0-25	Current power-on time	1Min	7019H
U0-26	current running time	0.1Min	701AH
U0-27	Input pulse frequency	1Hz	701BH
U0-28	Communication settings	0.01%	701CH
U0-29	Encoder feedback speed	0.01Hz	701DH
U0-30	main frequency display	0.01Hz	701EH
U0-31	Auxiliary frequency display	0.01Hz	701FH
U0-32	reserve		
U0-33	reserve		
U0-34	Motor temperature value	1 °C	7022H
U0-35	Target torque (%)	0.1%	7023H
U0-36	Resolver position	1	7024H
U0-37	power factor angle	0.1°	7025H
U0-38	ABZ position	1	7026H
U0-39	V/F separation target voltage	1V	7027H
U0-40	V/F separation output voltage	1V	7028H
U0-41	Visual display of X input status	1	7029H
U0-42	Visual display of DO output status	1	702AH

U0-43	Visual display of X function status 1 ( function 01-40)	1	702BH
U0-44	Visual display of X function status 2 ( function 41-80)	1	702CH
U0-45	reserve		
U0-46	reserve		
U0-47	reserve		
U0-48	reserve		
U0-49	reserve		
U0-50	reserve		
U0-51	reserve		
U0-52	reserve		
U0-53	reserve		
U0-54	reserve		
U0-55	reserve		
U0-56	reserve		
U0-57	reserve		
U0-58	Z signal counter	1	703AH
U0-59	Set frequency (%)	0.01%	703BH
U0-60	Operating frequency(%)	0.01%	703CH
U0-61	Inverter status	1	703DH
U0-62	current fault code	1	703EH
U0-63	reserve		
U0-64	reserve		
U0-65	Torque upper limit	0.1%	7041H
U0-66	reserve		
U0-67	reserve		
U0-68	reserve		
U0-69	reserve		
U0-70	reserve		
U0-71	reserve		
U0-72	reserve		
U0-73	motor selection		
U0-74	reserve		
U0-75	Inverter module heat sink temperature	1°C	-
U0-76	Product X	-	-
U0-77	Cumulative running time	1 hour	-
U0-78	Performance version number	-	-
U0-79	feature version number	-	-
U0-80	Cumulative power-on time	1 hour	-
U0-81	cumulative power consumption	1 degree	-
U0-82	Cumulative low power consumption	0.1 degrees	
U0-83	Cumulative high power consumption	1 degree	
U0-84	Inverter rated capacity	0.1kW	
U0-85	Inverter rated current	0.01A	

Group U3 (Reserved)

# CHINT

## QC PASS

NVF3 Series  
Inverter  
User Instruction  
IEC 61800-3

**Check 05**

Test date: Please see the packing

ZHEJIANG CHINT ELECTRICS CO., LTD.

### Guarantee card

#### Product and information of user

Product name: \_\_\_\_\_

Product model specification: \_\_\_\_\_

Product (or packing box) bar code (eighteen or nineteen): \_\_\_\_\_

Production date: \_\_\_\_\_ Buy date: \_\_\_\_\_

Buyer: \_\_\_\_\_ Number: \_\_\_\_\_

Address: \_\_\_\_\_

Agency: \_\_\_\_\_ Number: \_\_\_\_\_

Address: \_\_\_\_\_

#### Maintenance record:

Date	Fault description	Maintenance record

Serviceman sign: \_\_\_\_\_ Serviceman number: \_\_\_\_\_

**CHINT**

CHINT ELECTRICS

NVF3 Series  
Inverter  
User Instruction

**Zhejiang Chint Electrics Co., Ltd.**

Add: No.1, CHINT Road, CHINT Industrial Zone, North Baixiang,  
Yueqing, Zhejiang 325603, P.R.China

E-mail: [global-sales@chint.com](mailto:global-sales@chint.com)

Website: <http://en.chint.com>

0463V1618.EN

