



NJBK6 Motor Protection Relay

1. General

NJBK6 series motor protection relay is used to provide overload, phase failure, three-phase current unbalance and locked rotor protection for AC motors with a frequency of AC 50Hz, a rated insulation voltage of below 690V and a rated operational current of 1A~36A that operate continuously or intermittently.
Standards: IEC 60947-4-1



4. Technical data

4.1 Main data and technical characteristics

No.	Setting current range	Model of matching contactor	Matching motor power
NJBK6-36/3/□	1A~3A	CJX2-25/NC1-25	0.5kW~1.5kW
NJBK6-36/9/□	3A~9A	CJX2-25/NC1-25	1.5kW~4.5kW
NJBK6-36/24/□	8A~24A	CJX2-25/NC1-25	4kW~12kW
NJBK6-36/36/□	12A~36A	CJX2-32/NC1-32	6kW~18kW

4.2 Technical data of main circuit

Rated operational current: 1A~36A,
rated insulation voltage: 690V, rated frequency: 50Hz;

4.3 Technical data of control circuit

Number of contacts: 1 group of change-over contacts;
Contact capacity: Ue/Ie: AC-15 380V/0.95A, 240V/1.5A;
Ith: 5A; Rated frequency: 50Hz;

2. Type designation

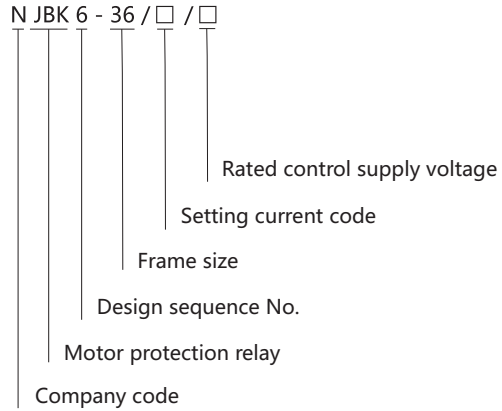

3. Operating conditions

- 3.1 Altitude: should not exceed 2000m;
- 3.2 Ambient temperature: -5°C~+40°C, and the average temperature in 24h should not exceed +35°C ;
- 3.3 Atmospheric conditions: The relative air humidity should not exceed 50% at the maximum temperature of +40°C. The relative humidity may be higher at lower temperatures, for example, the air humidity can be up to 90% at +20°C. Special measures should be taken if condensation occurs on the product occasionally due to temperature variation;
- 3.4 Pollution degree: 3;
- 3.5 The inclination between the mounting plane and the vertical plane should not exceed ±5°;
- 3.6 In non-explosive media that do not contain a sufficient amount of gas or conductive dust to cause metal corrosion or insulation failure;
- 3.7 In places with rain and snow protection equipment and not full of vapor;
- 3.8 In places where there is no significant shake, impact or vibration;
- 3.9 Mounting category: III

4.4 Technical data of auxiliary circuit

Control supply voltage: AC 220×(1±10%)V,
AC 380×(1±10%)V; Rated frequency: 50Hz;

4.5 Operating characteristics

4.5.1 The operating characteristics of overload protection are given in Table 2

No.	Setting current multiple	Operation time	Starting conditions	Starting conditions
1	1.05	No operation within 2h	Cold state	+20°C
2	1.2	Operation within 2h	Hot Start	+20°C
3	1.5	Operation within 2min	Hot Start	+20°C
4	7.2	2s < Tp ≤ 10s	Cold state	+20°C

4.5.2 Operating characteristic of phase failure protection

The protector will actuate within 3s if any of the three phases of main circuit currents is open and its relative error is ±20%.

4.5.3 Operating characteristic of unbalance protection of three phases of currents

The protector will actuate within 3s if the three phases of main circuit currents meet following two formulas at the same time and its relative error is ±20%.

$$\frac{\sum_{i=1}^3 \max |I_i - I_{avg}|}{I_{avg}} \times 100\% > 30\%$$

Hereinto:

I_i- Effective value per phase current

I_{avg}- Mean value of the three phases of currents

4.5.4 Operating characteristic of latching protection

The latching current of the protector is set as 6I_e. When the main circuit current is larger than the latching current, the protector will defer the actuation, and its actuation time is 3s and its relative error is ±20%.

4.6 Reset characteristics

After the operation of the protector, if the control supply voltage is normal, the protector can be reset manually; if the control supply voltage is off, the protector resets immediately.

5. Connection diagram

The connection diagrams in case the control supply voltage is AC220V and AC380V are shown in Figure 1 and Figure 2.

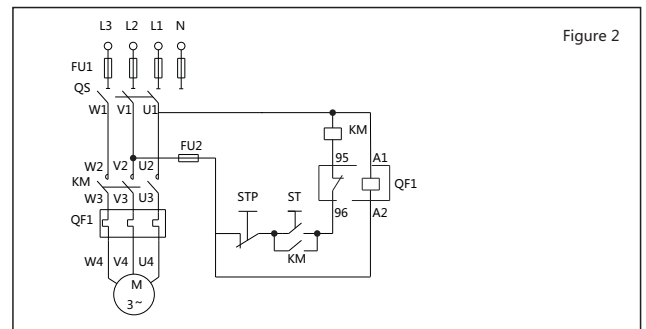
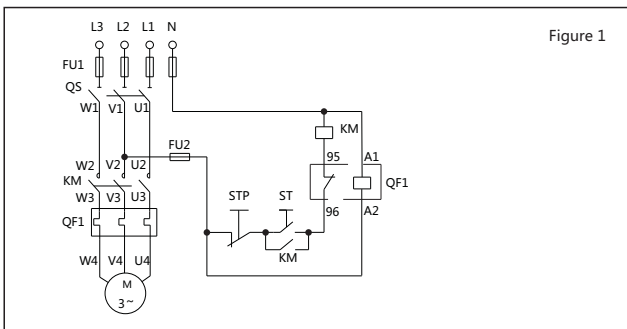

6. Installation and commissioning

6.1 Before installation, read the operating instructions carefully. Then, connect the wires in accordance with the connection diagram.

6.1.1 Terminals A1 and A2 are the control power supply input terminals of the protector; 95 and 96 are the output control terminals (N/C), 95 and 98 are N/O contacts.

6.1.2 Plug the protector into the outlet terminal of the contactor and connect the control circuit in accordance with Figure 2 and Figure 3.

6.2 Adjustment of setting current value

Adjust the setting value of the protector using the setting knob with indicating arrow and the setting current value on the label plate according to the rated current marked on the motor nameplate and the load conditions of the motor. Adjust the setting current value of the protector to the scale equal to the rated current value marked on the motor nameplate.

6.3 Commissioning: After checking the connection and setting, switch on the power supply and operate the start button. The motor should run normally and the (green) running indicator on the protector panel should light up. If the red indicator flashes, finely adjust the setting value until the red indicator stops flashing.

7. Structure and principle

7.1 Operating principle: The protector detects the current of the main circuit of the motor by means of the current transformer and judge if overload or phase failure has occurred in the motor. In case of overload, it simulates the heat accumulation state of the motor by means of the singlechip and, when the heat accumulation reaches the set limit, disconnects the N/C contact of the built-in electromagnetic relay.

7.2 Structural features

7.2.1 Has phase failure, overload, three-phase current unbalance and locked rotor protection functions.

7.2.2 Has two indicators indicating running and fault states.

7.2.3 Has a setting current quantified continuously adjustable device.

7.2.4 The main circuit uses plug-in connection for use in combination with the specified model of contactor.

8. Overall and mounting dimensions (mm)

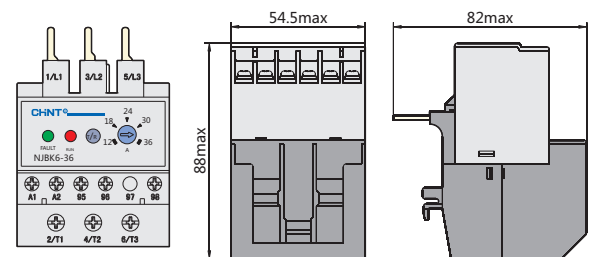

9. Environmental conditions for the storage of the protector

9.1 Temperature: -25°C~+40°C

9.2 Relative humidity (at 25°C): should not exceed 85%

9.3 Protect from rain and snow

9.4 The guaranteed storage period of the product is 18 months. Products exceeding the storage period must be reinspected before being put into use.

